

Aug.1.2018 Copyright 2018 HIROSE ELECTRIC CO., LTD. All Rights Reserved.
 In case that the application demands a high level of reliability, such as automotive,
 please contact a company representative for further information.

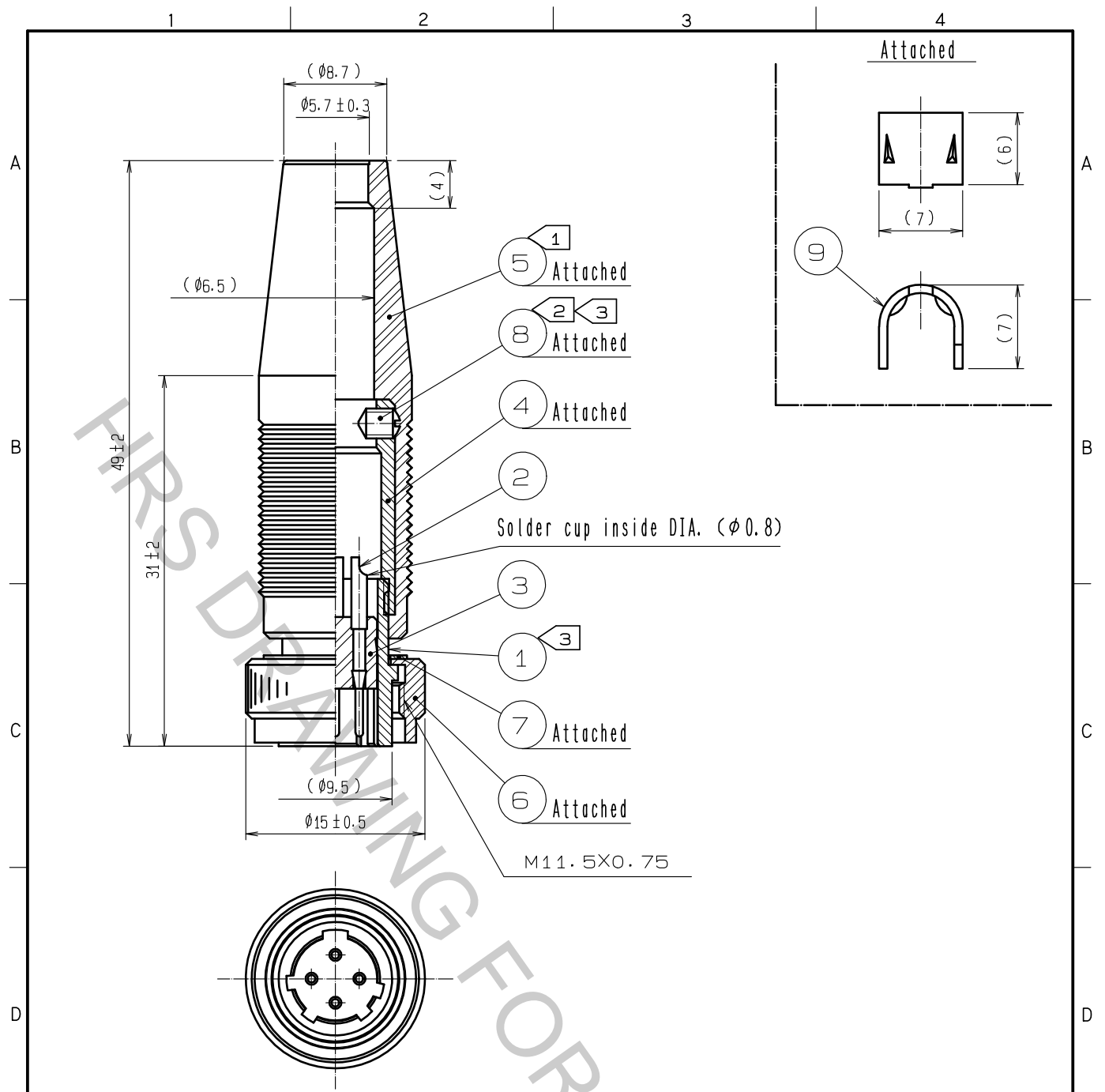

- Notes
- ① The recommended clamp torque of REF. No. ④ : 1.5 N·m.
 - ② The recommended clamp torque of REF. No. ⑧ : 0.1 to 0.15 N·m.
 - ③ LOCTITE 243 (HENKEL JAPAN), or equivalent is recommended to prevent REF. No. ④ and No. ⑧ from loosening.
 - 4. Rotation example of REF. No. ① and No. ④ are shown.

5	Chloroprene rubber	(Black)			
4	Brass	Nickel plating	9	Brass	
3	Polyacetal	(White)	8	Steel	Chromate treatment (Trivalent chromium) JIS B 1117 M2.5X3
2	Brass	Surface plating : Gold plating 0.2µm min. Under plating : Nickel plating 3µm min.	7	Brass	Chrome plating
1	Zinc alloy	Nickel plating	6	Brass	Chrome plating
NO.	MATERIAL	FINISH . REMARKS	NO.	MATERIAL	FINISH . REMARKS

UNITS mm		SCALE 2 : 1	COUNT 	DESCRIPTION OF REVISIONS	DESIGNED	CHECKED	DATE	
HIROSE ELECTRIC CO., LTD.		APPROVED : HY. KOBAYASHI	18.02.26	DRAWING NO.	EDC-022450-31-00			
		CHECKED : HY. KOBAYASHI	18.02.26	PART NO.	SR30-10PM-4P(31)			
		DESIGNED : TH. KAMEYA	18.02.26	CODE NO.	CL103-0341-9-31		1	1
		DRAWN : TH. KAMEYA	18.02.26					