

- △ HOUSING-MATERIAL : LIQUID-CRYSTAL-POLYMER.
- △ CONTACT-MATERIAL : PHOS. BRONZE.
- △ LATCH-MATERIAL : STAINLESS STEEL.
- △ CONTACT-PLATE 0.00127 [.000050] MIN NICKEL ALL OVER.
- △ CONTACT-PLATE 0.00076 [.000030] MIN. GOLD AT CONTACT PTS.
- △ CONTACT SOLDERTAILS-PLATE 0.00508 [.000200] MIN MATTE TIN.
- 7. IN ADDITION TO THOSE RECOMMENDED "SIMM" P.C. BOARD DIMENSIONS AND TOLERANCES SHOWN, ALL JEDEC SPECIFICATIONS APPLY AS SHOWN ON MO-116, ISSUE A.
- 8. RECOMMENDED MATING S.I.M.M. TAB METALLURGY: BASE METAL-COPPER. PLATING TO BE 0.00076 [.000030] MIN GOLD OVER 0.00127 [.000050] MIN NICKEL.
- △ 'S' IDENTIFIER LOCATED APPROXIMATELY AS SHOWN.
- △ 10 DATE CODE INFORMATION (YEAR WEEK), LOCATED APPROXIMATELY AS SHOWN ON OPPOSITE SIDE ONLY.

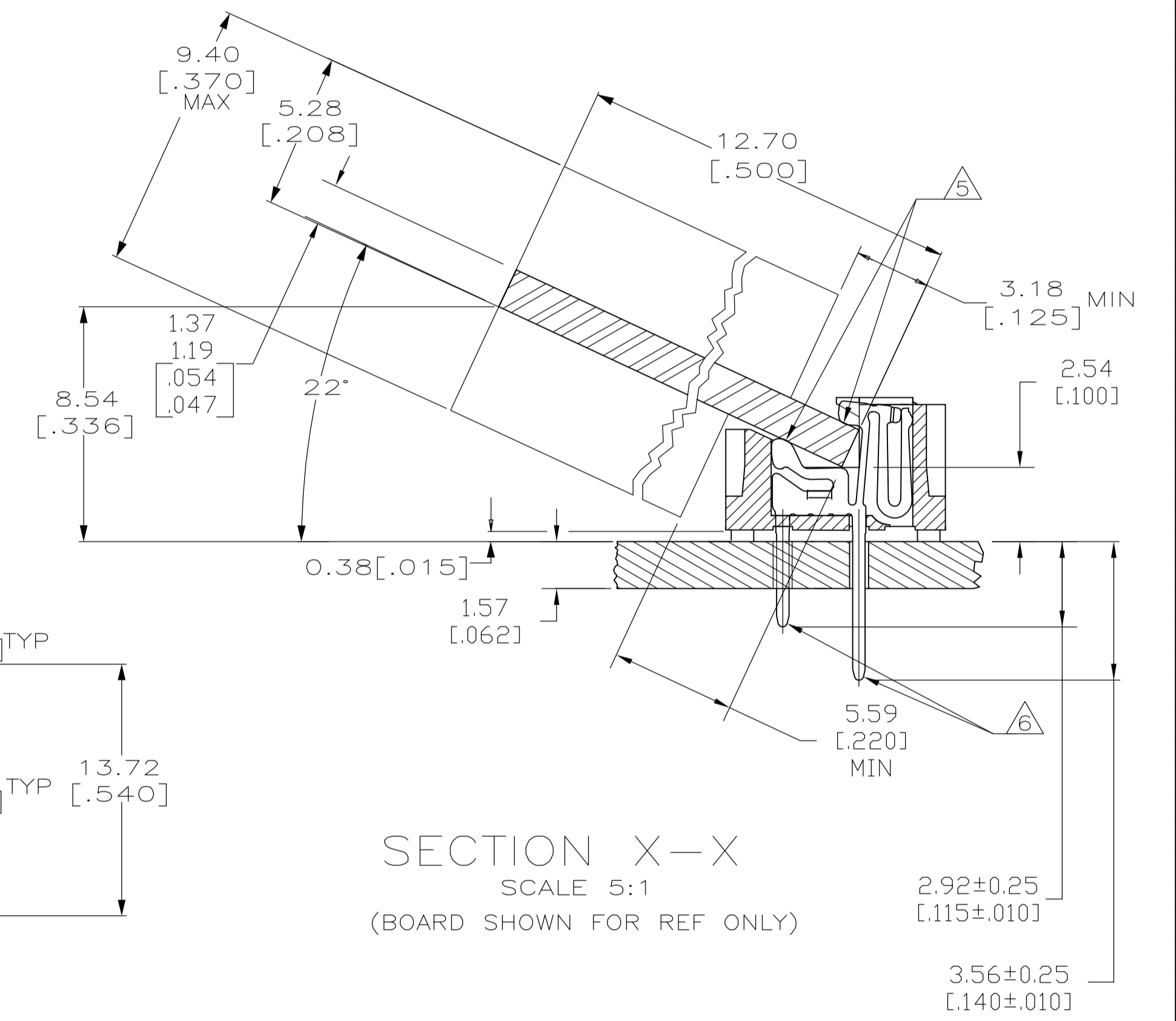

|               |               |              |              |               |               |            |           |
|---------------|---------------|--------------|--------------|---------------|---------------|------------|-----------|
| 118.11[4.650] | 111.35[4.384] | 60.96[2.400] | 49.53[1.950] | 125.48[4.940] | 105.41[4.150] | 80         | 5822138-4 |
| 107.95[4.250] | 101.19[3.984] | 55.88[2.200] | 44.45[1.750] | 115.32[4.540] | 95.25[3.750]  | 72         | 5822138-3 |
| F             | E             | D            | C            | B             | A             | NO. OF POS | PART NO   |

|  |  |                            |   |
|--|--|----------------------------|---|
| THIS DRAWING IS A CONTROLLED DOCUMENT. |  | DIN 9137 MCMMASTER 07JAN04 | Tyco Electronics Corporation<br>Harrisburg, PA 17105-3608 |
| DIMENSIONS: mm [INCHES]                |  | 07JAN04                    |   |
| TOLERANCES UNLESS OTHERWISE SPECIFIED: |  | 07JAN04                    | Tyco Electronics Corporation<br>Harrisburg, PA 17105-3608 |
| 0 PLC ± -                              |  | 07JAN04                    |   |
| 1 PLC ± -                              |  | 07JAN04                    | CONNECTOR, MICRO-EDGE, .050, LP, GOLD PL. W/METAL LATCH   |
| 2 PLC ± -                              |  | 07JAN04                    |   |
| 3 PLC ± 0.13[.005]                     |  | 07JAN04                    | SIZE CAGE CODE DRAWING NO RESTRICTED TO                   |
| 4 PLC ± -                              |  | 07JAN04                    |   |
| ANGLES ± -                             |  | 07JAN04                    | A1 00779 5822138  |
| FINISH                                 |  | 07JAN04                    |   |
| MATERIAL                               |  | 07JAN04                    | SCALE 4:1 SHEET 1 OF 1 REV B                              |