

PART NUMBER	REV	FIRST USED
1385285-1	A	122500-1
1385285-2	A	565435-5

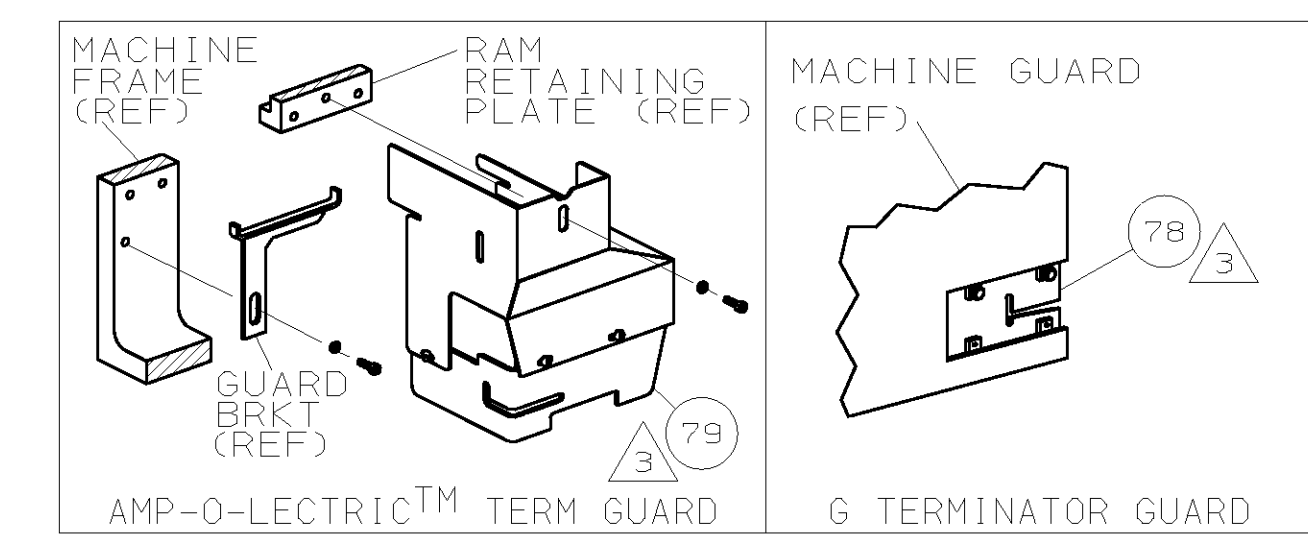

AMP PN		MFR PN		BRAININ TERMINAL AMP CRIMP SPECS	
286963		7249-5			
PAD LTR		CRIMP HEIGHT		WIRE SIZE	
A		.046 ±.002 [1.17 ±0.05mm]		18	
B		NOT		USED	
C		NOT		USED	
D		NOT		USED	
CRIMP		SIZE	TYPE	RANGE	
WIRE		.070 [1.78mm]	F	18	
INSUL		-	-	-	
WIRE STRIP LENGTH	TERM APPL SPEC	FEED	APPL INSTRUCTION	SET UP GAGE	LAYOUT
.115-.131	NONE	.535	408-8039	458638-1	L2545

QTY	REV	U/M	DWG SIZE	PART NO	DESCRIPTION	ITEM NO			
-1				LEADMAKER & BENCH MODEL G	AIR FEED				
-2				BENCH MODEL K	AIR FEED				
1				1	-	C	692655-5	AIR FEED VALVE ASSY	70
REF				-	-	A	24042-2	VALVE, SHUT OFF	67
REF				-	-	C	692655-6	AIR FEED VALVE ASSY	66
1				1	-	B	2-460277-1	AIR FEED ASSY (1 INCH)	65
2				2	-	A	3-21000-9	SCR,SHC (10-32x1.00)AIR ASSY	64
-				1	-	A	980285-2	ELBOW, SWIVEL 1/8 NPT - 1/4 T	63
-				1	-	A	23238-1	QUICK DISCONNECT	62
-				12.00	IN	A	27319-4	TUBING, POLY-FLO Ø.25	61
1				1	-	C	454220-1	CAP, RAM	59
1				1	-	D	453736-1	HOUSING	58
2				2	-	C	3-354779-1	PIN, WIRE DISC (.3145)A	126
1				1	-	A	986950-1	WASHER, FLAT PRECISION	125
1				1	-	A	217238-1	GENERAL INSTRUCTION PACKAGE	124
1				1	-	-	4088039	EF APPL INST 408-8039	123
1								122	
								121	
								120	
								119	
								118	
								117	
								116	
								115	
								114	
2				2	-	A	21024-5	WASHER, LOCK (#10)AIR ASSY	113
								112	
								111	
7				7	-	A	21024-4	WASHER, LOCK (NO.8)SHEAR BL	110
								109	
2				2	-	A	21018-4	NUT, HEX (4-40)DRAG	108
								107	
								106	
2				2	-	A	21022-2	NUT, HEX 5L (8-32)DRAG STUD	105
								104	
								103	
2				2	-	A	2-21006-6	SCR,SKT SET (4-40x.62)DRAG	102
1				1	-	A	21009-2	SCR,SKT SET (1/4-20x.25 )RAM	101
2				2	-	A	21017-2	SCR,DRIVE (#2x.19) ID PLATE	100
								99	
1				1	-	B	461264-1	PLATE, IDENTIFICATION	98
								97	
								96	
2				2	-	A	2-21002-2	SCR,BHC (8-32x.50)STRIPPER	95
4				4	-	A	2-21002-9	SCR,BHC (10-32x.75)CAP	94
1				1	-	A	22733-8	SCR,BHC (8-32x.38 LW)ANVIL	93
4				4	-	A	3-21002-3	SCR,BHC (1/4-20x.50)ST 6D PL	92
3				3	-	A	2-22733-8	SCR,BHC (1/4-20x.62)H5G	91
4				4	-	A	1-21000-3	SCR,SHC (4-40x.25)DRAG	90
								89	
								88	
2				2	-	A	2-21000-6	SCR,SHC (8-32x.38)SLUG BLADE	87
3				3	-	A	2-21000-6	SCR,SHC (8-32x.38)STP GUIDE	86
2				2	-	A	2-21000-9	SCR,SHC (8-32x.75)STP GUIDE	85
								84	
								83	
								82	
								81	
2				2	-	A	2-21002-9	SCR,BHC (10-32x.75)SHEAR PL	80
1				-	-	A	455750-7	GUARD ASSY	79
-				REF	-	A	679532-1	INSERT, GUARD	78
								77	
								76	
								75	
								74	
								73	
								72	
								71	
-2	-1	U/M	DWG SIZE	PART NO	DESCRIPTION	ITEM NO			
QTY REOD PER ASSY PARTS LIST									

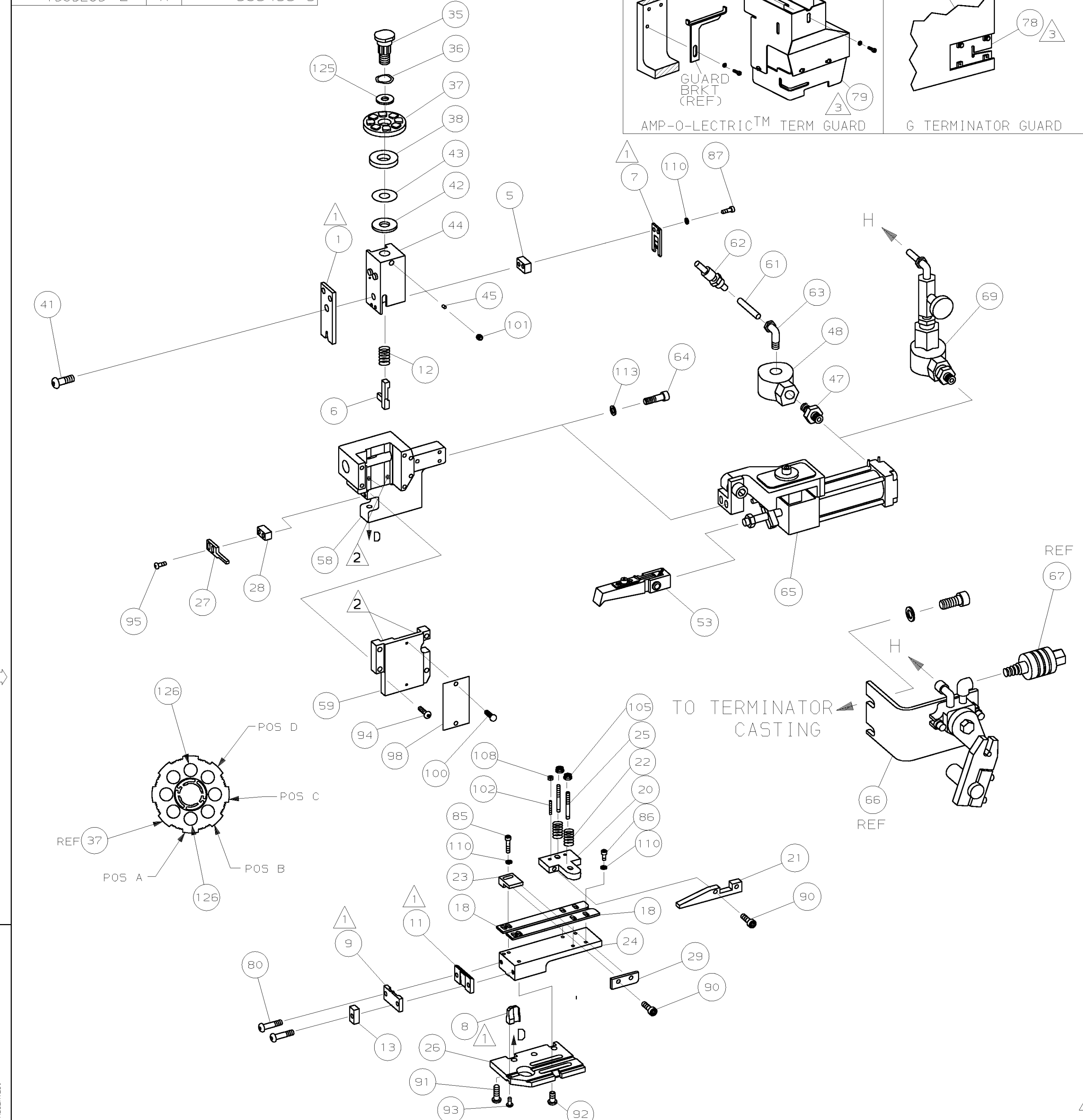

- 1 RECOMMENDED SPARE PARTS.
- 2 GREASE LIGHTLY.
- 3 GUARD MUST BE IN PLACE WHEN OPERATING APPLICATOR IN A BENCH MACHINE.
- 4 SEE DRAWING FOR COMPONENTS
- 5 ITEM 78 USED WITH G TERMINATOR ONLY.

THIS DRAWING IS UNRELEASED. RELEASED FOR PUBLICATION BY AMP INCORPORATED. ALL RIGHTS RESERVED.

LOC A  
 DIST 66  
 AMP 1756 REV 3-92

DIMENSIONS IN INCHES. DO NOT SCALE PRINT. TOLERANCES UNLESS OTHERWISE SPECIFIED:		MATERIAL		HT TR		FIN	
2 PLC DEC ±.25		DR B.HIGMAN		29JUN01		APP T.ELBIN	
3 PLC DEC ±		CHK		REL		AMP	
4 PLC DEC ±		NAME		END FEED HDM APPLICATOR		MACHINE REF MINI APPL	
ANGLES ±		SCALE		DWG NO		1385285	
SURF TEXTURE: ✓		REMOVE BURRS, BREAK SHARP EDGES R.015 MAX		SHEET		1 OF 1	
REVISION RECORD		DATE		REV		A	
CUSTOMER AND ASSEMBLY DRAWING							