

# Constant Current LED Drivers for Automotive

## Constant Current Controller for Automotive LED Lamps

**BD18340FV-M BD18341FV-M**

### General Description

BD18340FV-M/BD18341FV-M are 70V-withstanding Constant Current Controller for Automotive LED Lamps. It is able to drive at maximum 10 rows of PNP transistors. It can also contribute to reduction in the consumption power of the set as it has the integrated standby function., The IC also incorporates a highly reliable, in-built de-rating function, LED Open Detection, Short Circuit Protection and Over Voltage Mute function and LED failure input/output function.

### Features

- AEC-Q100 Qualified<sup>(Note1)</sup>
  - LED Constant-Current Controller
  - PWM Dimming Function
  - LED Current De-rating Function
  - LED Open Detection
  - Short Circuit Protection(SCP)
  - Over Voltage Mute Function(OVM)
  - Disable LED Open Detection Function at Reduced-Voltage
  - Abnormal Output Detection and Output Functions
- (Note1: Grade1)

### Applications

- Automotive LED Exterior Lamp (Rear Lamp, Turn Lamp, DRL/Position Lamp, Fog Lamp etc.)
- Automotive LED Interior Lamp (Air Conditioner Lamp, Interior Lamp, Cluster Light etc.)

### Key Specifications

- Input Voltage Range : 4.5V to 19V
- FB Terminal Voltage Accuracy : 650mV ±3%  
@Ta = 25°C to 125°C
- Stand-by Current : 0µA(Typ)
- LED Current De-rating Accuracy :  
BD18340FV-M : ± 5% @V<sub>DCDIM</sub>=0.5 to 0.75V  
BD18341FV-M : ± 12% @V<sub>DCDIM</sub>=0.5 to 0.75V
- Operating Temperature Range : -40°C to +125°C

### Package

SSOP-B16

**W(Typ) x D(Typ) x H(Max)**

5.00mm x 6.40mm x 1.35mm



### Typical Application Circuit

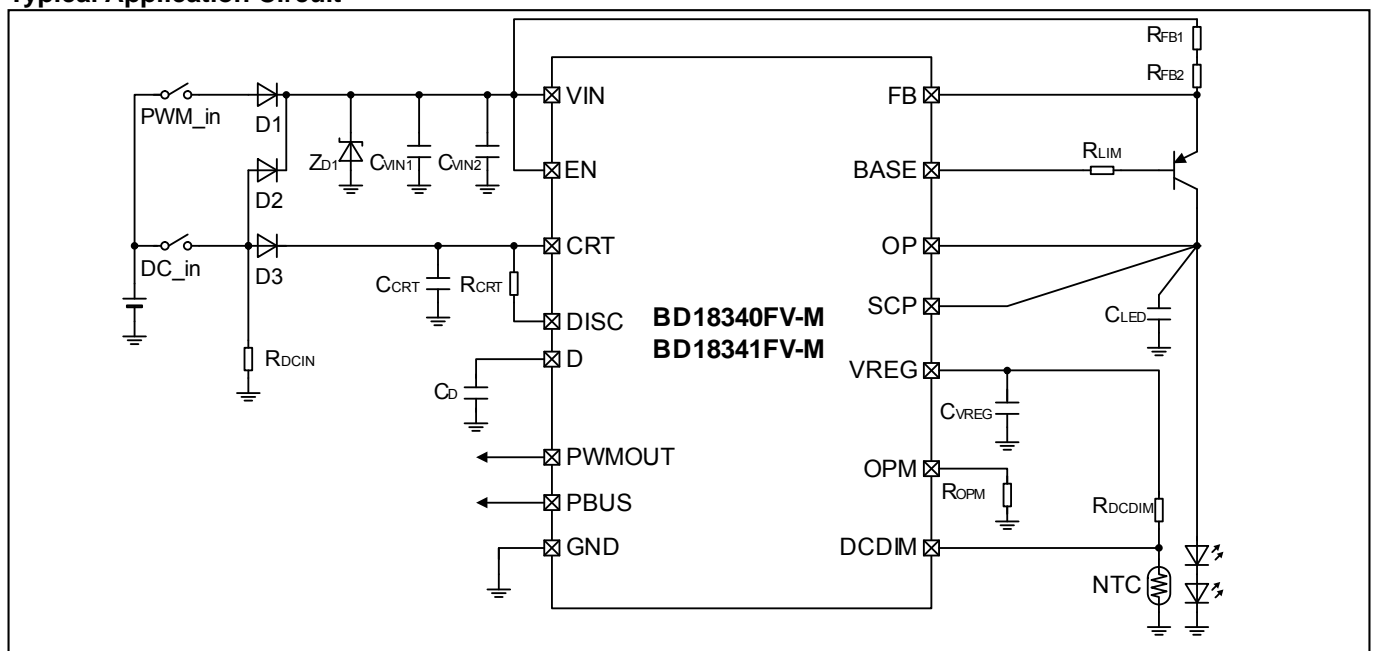

○Product structure : Silicon monolithic integrated circuit ○This product has no designed protection against radioactive rays

Pin Configuration

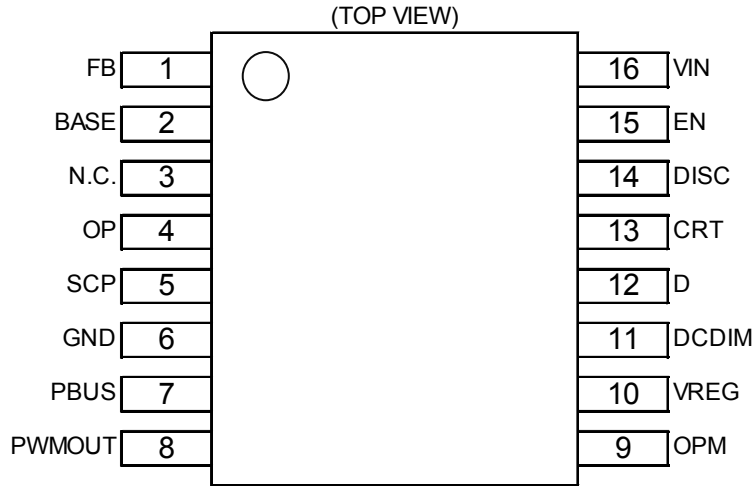

Pin Description

Pin No.	Pin Name	Function	Pin No.	Pin Name	Function
1	FB	Input terminal for feedback voltage	9	OPM	The terminal to set Disable LED open detection voltage
2	BASE	The terminal for connecting PNP Tr. BASE	10	VREG	Internal reference voltage
3	N.C.	Pin not connected internally. (Note 1)	11	DCDIM	The terminal to set DC dimming
4	OP	The terminal for LED open detection	12	D	The terminal to set Disable LED open detection time
5	SCP	The terminal for short circuit protection	13	CRT	The terminal to set CR timer
6	GND	GND	14	DISC	Discharge terminal for CR timer
7	PBUS	The terminal Abnormal Output Detection and Output	15	EN	Enable input
8	PWMOUT	CR timer signal output	16	VIN	Power supply input

(Note 1) Please be sure to floating at N.C. pin

Block Diagram

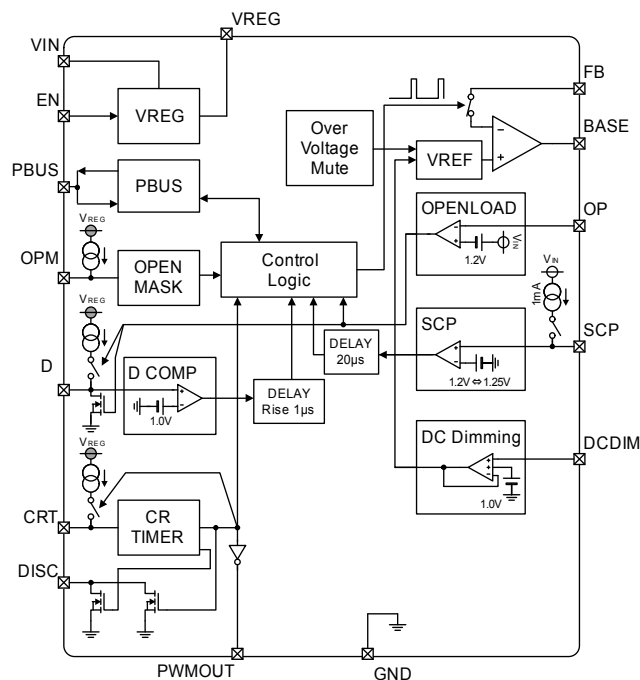

**Absolute Maximum Ratings (Ta=25°C)**

Parameter	Symbol	Rating	Unit
Supply Voltage	V <sub>IN</sub>	-0.3 to +70	V
EN,CRT, DISC Terminal Voltage	V <sub>EN</sub> , V <sub>CRT</sub> , V <sub>DISC</sub>	-0.3 to +70	V
FB,BASE,OP,SCP Terminal Voltage	V <sub>FB</sub> , V <sub>BASE</sub> , V <sub>OP</sub> , V <sub>SCP</sub>	-0.3 to V <sub>IN</sub> +0.3V	V
VIN-FB, VIN-BASE Voltage across Terminals	V <sub>IN</sub> -V <sub>FB</sub> , V <sub>IN</sub> -V <sub>BASE</sub>	-0.3 to +5.0	V
PBUS,VREG DCDIM Terminal Voltage	V <sub>PBUS</sub> , V <sub>REG</sub> , V <sub>DCDIM</sub>	-0.3 to +7.0	V
PWMOUT, OPM, D Terminal Voltage	V <sub>PWMOUT</sub> , V <sub>OPM</sub> , V <sub>D</sub>	-0.3 to V <sub>REG</sub> +0.3	V
Operating Temperature Range	T <sub>opr</sub>	-40 to 125	°C
Storage Temperature Range	T <sub>stg</sub>	-55 to 150	°C
Junction Temperature	T <sub>jmax</sub>	150	°C

**Caution:** Operating the IC over the absolute maximum ratings may damage the IC. The damage can either be a short circuit between pins or an open circuit between pins and the internal circuitry. Therefore, it is important to consider circuit protection measures, such as adding a fuse, in case the IC is operated over the absolute maximum ratings.

**Thermal Resistance (Note2)**

Parameter	Symbol	Thermal Resistance (Typ)		Unit
		1s <sup>(Note4)</sup>	2s2p <sup>(Note5)</sup>	
SSOP-B16				
Junction to Ambient	θ <sub>JA</sub>	140.9	77.2	°C/W
Junction to Top Characterization Parameter <sup>(Note 3)</sup>	Ψ <sub>JT</sub>	6	5	°C/W

(Note2) Based on JESD51-2A (Still-Air).

(Note3) The thermal characterization parameter to report the difference between junction temperature and the temperature at the top center of the outside surface of the component package.

(Note4) Using a PCB board based on JESD51-3.

Layer Number of Measurement Board	Material	Board Size
Single	FR-4	114.3mm x 76.2mm x 1.57mmt

Top	
Copper Pattern	Thickness
Footprints and Traces	70µm

(Note5) Using a PCB board based on JESD51-7

Layer Number of Measurement Board	Material	Board Size
4 Layers	FR-4	114.3mm x 76.2mm x 1.6mmt

Top		2 Internal Layers		Bottom	
Copper Pattern	Thickness	Copper Pattern	Thickness	Copper Pattern	Thickness
Footprints and Traces	70µm	74.2mm x 74.2mm	35µm	74.2mm x 74.2mm	70µm

## Recommended Operating Conditions (Ta=-40°C to +125°C)

Parameter	Symbol	Min	Typ	Max	Unit
Supply Voltage <sup>(Note1)</sup> <sup>(Note2)</sup>	V <sub>IN</sub>	4.5	13	19	V
CRTIMER Frequency Range	f <sub>PWM</sub>	100	-	5000	Hz
PWM Minimum Pulse Width <sup>(Note3)</sup>	t <sub>MIN</sub>	10	-	-	μs

(Note1) ASO should not be exceeded

(Note2) At start-up time, please apply a voltage above 5V once. The value is the voltage range after the temporary rise to 5V.

(Note3) At connecting the External PNP Tr.(2SAR573D(ROHM) ,1pcs), That is the same when the Pulse input to CRT terminal.

## Operating Conditions

Parameter	Symbol	Min	Max	Unit
The Capacitor connecting VIN Terminal1	C <sub>VIN1</sub>	1.0	-	μF
The Capacitor connecting VIN Terminal2	C <sub>VIN2</sub> <sup>(Note4)</sup>	0.047	-	μF
The Capacitor connecting VREG Terminal	C <sub>VREG</sub> <sup>(Note5)</sup>	1.0	4.7	μF
The Capacitor connecting LED Anode	C <sub>LED</sub>	0.1	0.68	μF
The Capacitor connecting CRT Terminal	C <sub>CRT</sub>	0.01	0.22	μF
The Resistor connecting CRT Terminal	R <sub>CRT</sub>	0.1	50	kΩ
The Resistor for setting LED Current LED	R <sub>FB1</sub> , R <sub>FB2</sub> <sup>(Note6)</sup>	0.8	6.5	Ω
The Resistor for setting Disable LED Open Detection Voltage	R <sub>OPM</sub>	25	55	kΩ
The Resistor for setting DC Dimming	R <sub>DCCDIM</sub>	4.7	50	kΩ
The Resistor for DCIN pull-down	R <sub>DCIN</sub>	-	10	kΩ
The Capacitor for setting Disable LED Open Detection Time	C <sub>D</sub> <sup>(Note5)</sup>	0.001	0.1	μF
The Resistor for limiting Base Terminal Current	R <sub>LIM</sub>	See Features Description 5		Ω
The External PNP Transistor	Q <sub>1</sub>	(Note7)		-

(Note4) ROHM Recommended Value (0.1μF GCM188R11H104KA42 murata)

(Note5) Ceramic capacitor recommended. Please setting the Disable LED Open Detection Time less than PWM minimum pulse width.

(Note6) At connecting the External PNP Tr. (2SAR573D (ROHM), 1pcs)

(Note7) For external PNP transistor, please use the recommended device 2SAR573D for this IC.

While using non-recommended part device, validate the design on actual board.

Please check hfe of the part to design base current limit resistor. (See Features Description, section 5).

As for parasitic capacitance, please evaluate over shoot of I<sub>LED</sub> on actual board. (See Features Description, Section 8 -Evaluation example, ILED pulse width at PWM Dimming operation).

**Electrical Characteristics1**(Unless otherwise specified Ta = -40 to +125°C, V<sub>IN</sub> = 13V, C<sub>VREG</sub> = 1.0μF, Transistor PNP = 2SAR573D)

Parameter	Symbol	Limit			Unit	Conditions
		Min	Typ	Max		
<b>[ Circuit Current I<sub>VIN</sub> ]</b>						
Circuit Current at Stand-by Mode	I <sub>VIN1</sub>	-	0	10	μA	V <sub>EN</sub> = 0V V <sub>FB</sub> = V <sub>IN</sub>
Circuit Current at Normal Mode	I <sub>VIN2</sub>	-	2.0	5.0	mA	V <sub>EN</sub> = V <sub>IN</sub> , V <sub>FB</sub> = V <sub>IN</sub> - 1.0V Base current subtracted
Circuit Current at LED Open Detection	I <sub>VIN3</sub>	-	2.0	5.0	mA	V <sub>EN</sub> = V <sub>IN</sub> , V <sub>FB</sub> = V <sub>IN</sub> - 1.0V at LED Open Detection
Circuit Current at PBUS=Low	I <sub>VIN4</sub>	-	2.0	5.0	mA	V <sub>EN</sub> = V <sub>IN</sub> , V <sub>FB</sub> = V <sub>IN</sub> - 1.0V V <sub>PBUS</sub> = 0V
<b>[ VREG Voltage ]</b>						
VREG Terminal Voltage	V <sub>REG</sub>	4.85	5.00	5.15	V	I <sub>VREG</sub> = -100μA Ta = 25 to 125°C
		4.75	5.00	5.25	V	I <sub>VREG</sub> = -100μA Ta = -40 to 125°C
VREG Terminal Current Capability	I <sub>VREG</sub>	-1.0	-	-	mA	
<b>[ DRV ]</b>						
FB Terminal Voltage	V <sub>FBREG</sub>	630	650	670	mV	V <sub>FBREG</sub> = V <sub>IN</sub> - V <sub>FB</sub> R <sub>FB1</sub> = R <sub>FB2</sub> = 1.8Ω, Ta = 25 to 125°C
		617	650	683	mV	V <sub>FBREG</sub> = V <sub>IN</sub> - V <sub>FB</sub> R <sub>FB1</sub> = R <sub>FB2</sub> = 1.8Ω, Ta = -40 to 125°C
FB Terminal Input Current	I <sub>FB</sub>	7.5	15	30	μA	V <sub>FB</sub> = V <sub>IN</sub>
BASE Terminal Sink Current Capability	I <sub>BASE</sub>	10	-	-	mA	V <sub>FB</sub> = V <sub>IN</sub> , V <sub>BASE</sub> = V <sub>IN</sub> - 1.5V Ta = 25°C
BASE Terminal Pull-up Resistor	R <sub>BASE</sub>	0.5	1.0	1.5	kΩ	V <sub>CRT</sub> = 0V V <sub>FB</sub> = V <sub>IN</sub> , V <sub>BASE</sub> = V <sub>IN</sub> - 1.0V
<b>[ LED Current De-rating Function (DC Dimming Function) ]</b>						
DC Dimming Gain	D <sub>DG</sub>	688	725	762	mV / V	$\frac{\Delta V_{FBREG}}{V} / \frac{\Delta V_{DCDIM}}{V}$ V <sub>DCDIM</sub> : 0.75V → 0.35V
<b>BD18340FV-M</b>						
FB Terminal Voltage V <sub>DCDIM</sub> = 0.75V	V <sub>FB_DC1</sub>	443	466	489	mV	
FB Terminal Voltage V <sub>DCDIM</sub> = 0.50V	V <sub>FB_DC2</sub>	270	284	298	mV	
FB Terminal Voltage V <sub>DCDIM</sub> = 0.35V	V <sub>FB_DC3</sub>	161	175	189	mV	
<b>BD18341FV-M</b>						
FB Terminal Voltage V <sub>DCDIM</sub> = 0.75V	V <sub>FB_DC1</sub>	413	466	522	mV	
FB Terminal Voltage V <sub>DCDIM</sub> = 0.50V	V <sub>FB_DC2</sub>	250	284	318	mV	
FB Terminal Voltage V <sub>DCDIM</sub> = 0.35V	V <sub>FB_DC3</sub>	155	175	196	mV	
<b>[ Over Voltage Mute Function(OVM) ]</b>						
Over Voltage Mute Start Voltage	V <sub>OVMs</sub>	20.0	22.0	24.0	V	$\Delta V_{FB} = 10.0\text{mV}$ $\Delta V_{FB} = V_{FB}(@V_{IN} = 13\text{V}) - V_{FB}(@V_{IN} = V_{OVM})$
Over Voltage Mute Gain	V <sub>OVMG</sub>	-	-25	-	mV / V	$\Delta V_{FB} / \Delta V_{IN}$

**Electrical Characteristics2**(Unless otherwise specified Ta = -40 to +125°C, V<sub>IN</sub> = 13V, C<sub>VREG</sub> = 1.0μF, Transistor PNP = 2SAR573D)

Parameter	Symbol	Limit			Unit	Conditions
		Min	Typ	Max		
<b>[ CRTIMER ]</b>						
CRT Terminal Charge Current	I <sub>CRT</sub>	36	40	44	μA	
CRT Terminal Charge Voltage	V <sub>CRT_CHA</sub>	0.72	0.80	0.88	V	
CRT Terminal Discharge Voltage 1	V <sub>CRT_DIS1</sub>	1.80	2.00	2.20	V	
CRT Terminal Discharge Voltage 2	V <sub>CRT_DIS2</sub>	2.10	2.40	3.00	V	When V <sub>CRT</sub> > V <sub>CRT_DIS2</sub> , R <sub>D1</sub> -> R <sub>D2</sub>
CRT Terminal Charge Resistor	R <sub>CHA</sub>	28.5	30.0	31.5	kΩ	R <sub>CHA</sub> = (V <sub>CRT_DIS1</sub> - V <sub>CRT_CHA</sub> ) / I <sub>CRT</sub>
CR Timer Discharge Constant	V <sub>CRT_CHA</sub> / V <sub>CRT_DIS1</sub>	0.38	0.40	0.42	V / V	
DISC Terminal ON Resistor 1	R <sub>DISC1</sub>	20	50	100	Ω	I <sub>DISC</sub> = 10mA
DISC Terminal ON Resistor 2	R <sub>DISC2</sub>	2.5	5.0	10	kΩ	I <sub>DISC</sub> = 100μA
PWMOUT Terminal Output High Voltage	V <sub>PWMOUTH</sub>	4.0	-	5.5	V	I <sub>PWMOUT</sub> = -100μA
PWMOUT Terminal Output Low Voltage	V <sub>PWMOUTL</sub>	-	-	0.5	V	I <sub>PWMOUT</sub> = 100μA
PWMOUT Terminal Sink Current Capability	I <sub>PWMOUT_SINK</sub>	-	-	0.5	mA	
PWMOUT Terminal Source Current Capability	I <sub>PWMOUT_SOURCE</sub>	-0.5	-	-	mA	
CRT Terminal Leakage Current	I <sub>CRT_LEAK</sub>	-	-	10	μA	V <sub>CRT</sub> = 70V
<b>[ LED Open Detection ]</b>						
LED Open Detection Voltage	V <sub>OPD</sub>	1.1	1.2	1.3	V	V <sub>OPD</sub> = V <sub>IN</sub> - V <sub>OP</sub>
OP Terminal Input Current	I <sub>OP</sub>	19	21	23	μA	V <sub>OP</sub> = V <sub>IN</sub> - 0.5V
<b>[ Disable LED Open Detection Function at Reduced-Voltage]</b>						
OPM Terminal Source Current	I <sub>OPM</sub>	38	40	42	μA	
VIN Terminal Disable LED Open Detection Voltage at Reduced-Voltage	V <sub>IN_OPM</sub>	V <sub>OPM</sub> × 5.9	V <sub>OPM</sub> × 6.0	V <sub>OPM</sub> × 6.1	V	VIN terminal Voltage
OPM Terminal Input Voltage Range	V <sub>OPM_R</sub>	1.0	-	2.2	V	
<b>[ Disable LED Open Detection Time Setting ]</b>						
Input Threshold Voltage	V <sub>DH</sub>	0.9	1.0	1.1	V	
D Terminal Source Current	I <sub>DSOURCE</sub>	100	230	400	μA	
D Terminal ON Resistor	R <sub>D</sub>	-	-	950	Ω	I <sub>D_EXT</sub> = 100μA

**Electrical Characteristics3**(Unless otherwise specified Ta = -40 to +125°C, V<sub>IN</sub> = 13V, C<sub>VREG</sub> = 1.0μF, Transistor PNP = 2SAR573D)

Parameter	Symbol	Limit			Unit	Conditions
		Min	Typ	Max		
<b>[ Short Circuit Protection(SCP) ]</b>						
Short Circuit Protection Voltage	V <sub>SCP1</sub>	1.1	1.2	1.3	V	
Short Circuit Protection Release Voltage	V <sub>SCP2</sub>	1.15	1.25	1.35	V	
Short Circuit Protection Hysteresis Voltage	V <sub>SCPHYS</sub>	-	50	-	mV	
SCP Terminal Source Current	I <sub>SCP</sub>	0.2	1.0	2.0	mA	
SCP Terminal Source Current ON Voltage	V <sub>SCP2</sub>	1.15	1.30	1.45	V	
SCP Delay Time	t <sub>SCP2</sub>	10	20	45	μs	
<b>[ PBUS ]</b>						
Input High Voltage	V <sub>PBUSH</sub>	2.40	-	-	V	
Input Low Voltage	V <sub>PBUSL</sub>	-	-	0.6	V	
Hysteresis Voltage	V <sub>PBUSHYS</sub>	-	200	-	mV	
PBUS Terminal Source Current	I <sub>PBUS</sub>	75	150	300	μA	V <sub>EN</sub> = 5V
PBUS Terminal Output Low Voltage	R <sub>PBUS</sub>	-	-	0.6	V	I <sub>PBUS_EXT</sub> = 3mA
PBUS Terminal Output High Voltage	V <sub>PBUS_OH</sub>	3.5	4.5	5.5	V	I <sub>PBUS_EXT</sub> = -10μA
PBUS Terminal Leakage Current	I <sub>PBUS_LEAK</sub>	-	-	10	μA	V <sub>PBUS</sub> = 7V
<b>[ EN ]</b>						
Input High Voltage	V <sub>ENH</sub>	2.4	-	-	V	
Input Low Voltage	V <sub>ENL</sub>	-	-	0.6	V	
Hysteresis Voltage	V <sub>ENHYS</sub>	-	60	-	mV	
Terminal Input Current	I <sub>EN</sub>	-	7	15	μA	V <sub>EN</sub> = 5V
<b>[ UVLO VIN ]</b>						
UVLO Detection Voltage	V <sub>UVLOD</sub>	3.88	4.10	4.32	V	V <sub>IN</sub> : Sweep down
UVLO Release Voltage	V <sub>UVLOR</sub>	4.25	4.50	4.75	V	V <sub>IN</sub> : Sweep up, V <sub>REG</sub> > 3.75V
UVLO Hysteresis Voltage	V <sub>HYS</sub>	-	0.4	-	V	

**Typical Performance Curves (Reference Data)**

(Unless otherwise specified  $T_a = 25^\circ\text{C}$ ,  $V_{IN} = 13\text{V}$ ,  $C_{VREG} = 1.0\mu\text{F}$ , Transistor PNP = 2SAR573D)

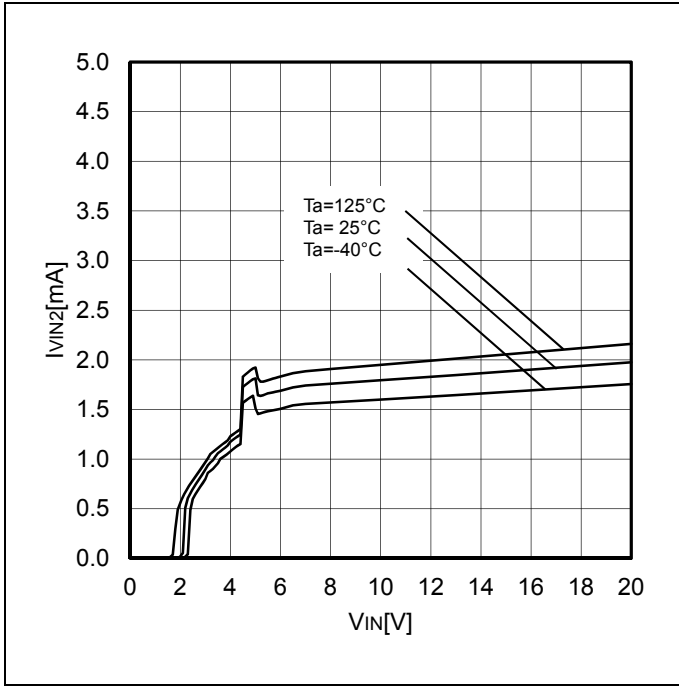

Figure 1.  $I_{VIN2}$  vs  $V_{IN}$

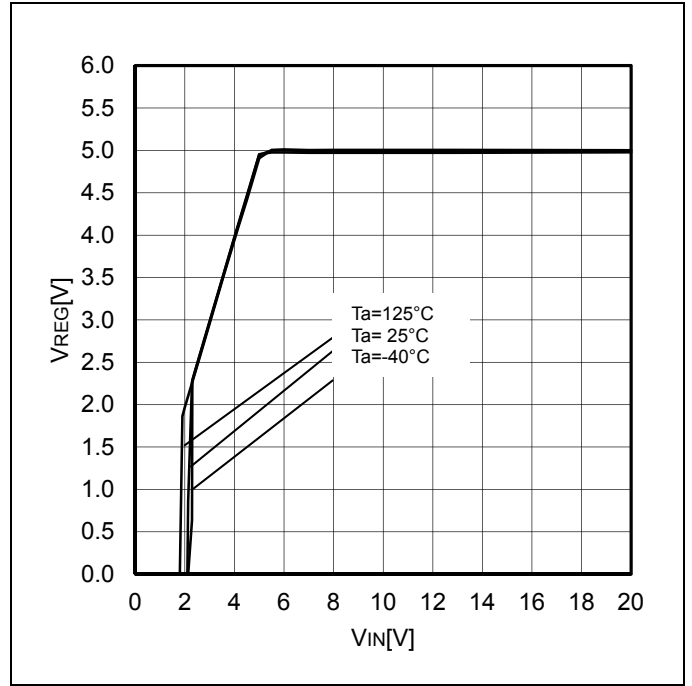

Figure 2.  $V_{REG}$  vs  $V_{IN}$

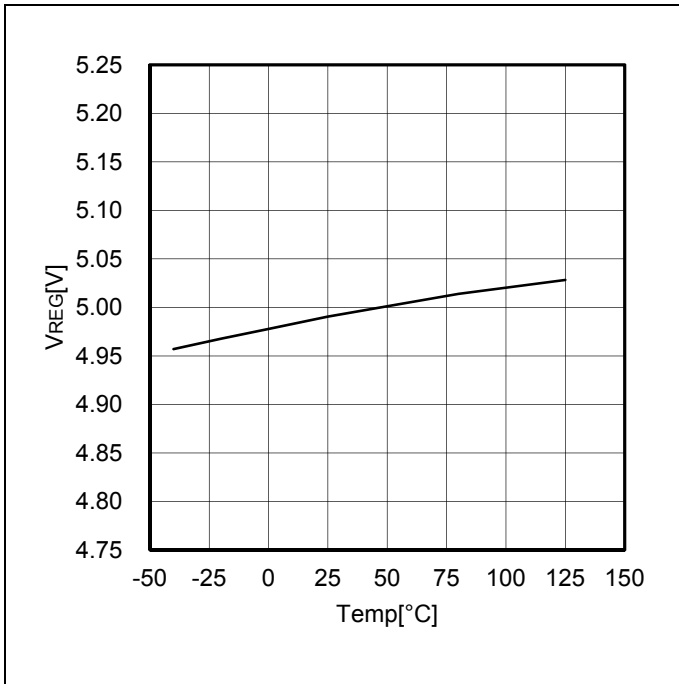

Figure 3.  $V_{REG}$  vs Temp

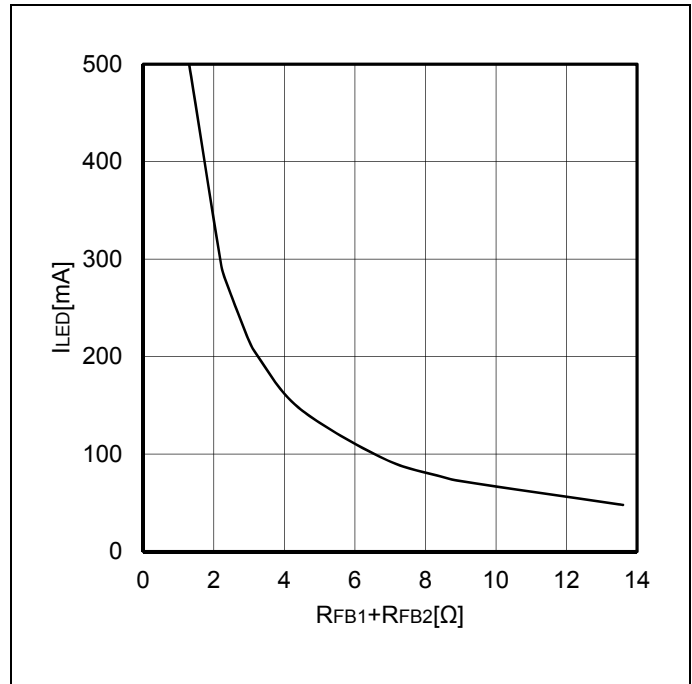

Figure 4.  $I_{LED}$  vs  $R_{FB1} + R_{FB2}$



**Typical Performance Curves (Reference Data)**

(Unless otherwise specified Ta = 25°C, VIN = 13V, CVREG = 1.0μF, Transistor PNP = 2SAR573D)

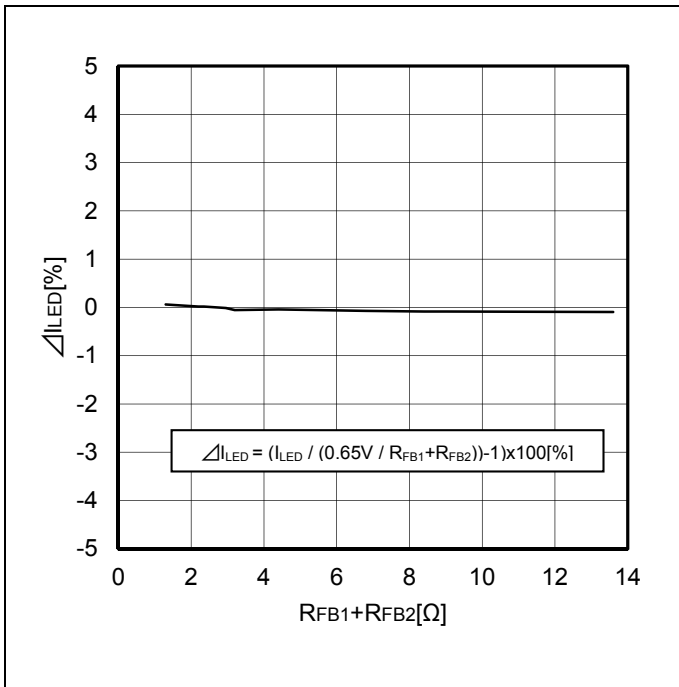

Figure 5.  $\Delta I_{LED}$  VS  $R_{FB1}+R_{FB2}$

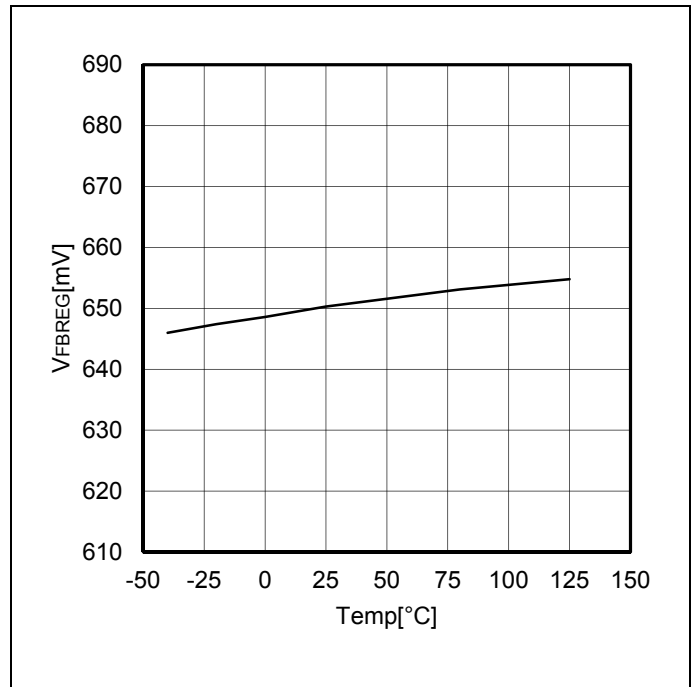

Figure 6.  $V_{FBREG}$  vs Temp

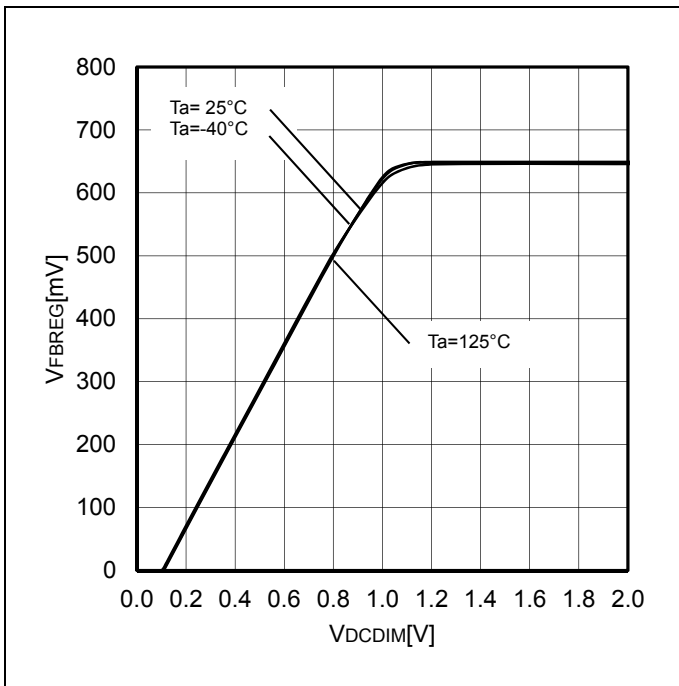

Figure 7.  $V_{FBREG}$  VS  $V_{DCDIM}$

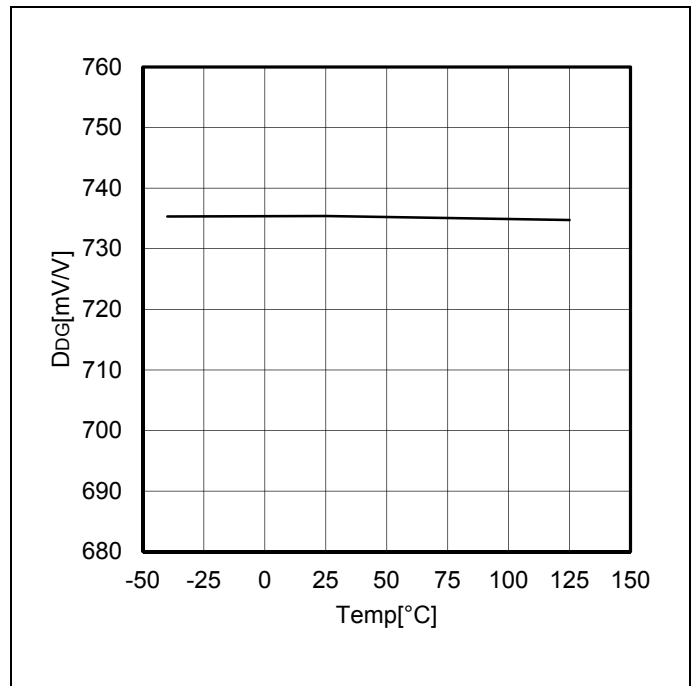

Figure 8.  $D_{DG}$  vs Temp

**Typical Performance Curves (Reference Data)**

(Unless otherwise specified  $T_a = 25^\circ\text{C}$ ,  $V_{IN} = 13\text{V}$ ,  $C_{VREG} = 1.0\mu\text{F}$ , Transistor PNP = 2SAR573D)

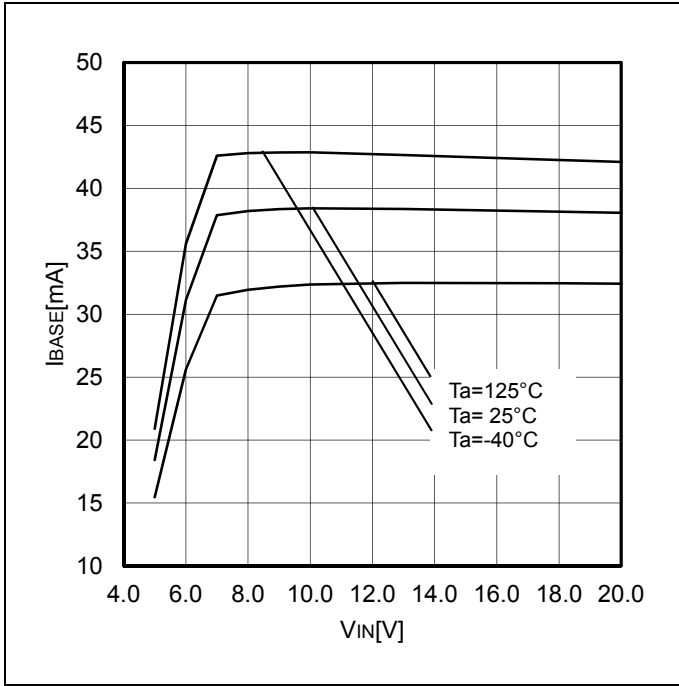

Figure 9.  $I_{BASE}$  vs  $V_{IN}$

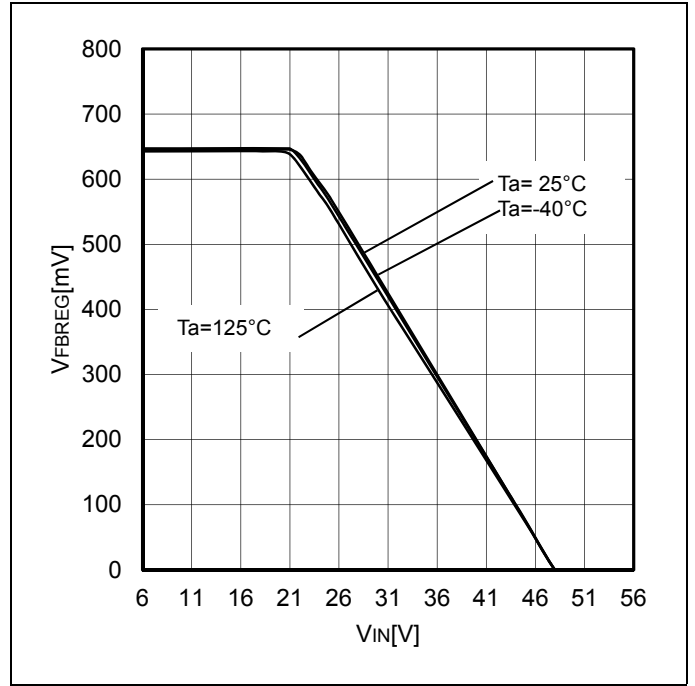

Figure 10.  $V_{FBREG}$  vs  $V_{IN}$

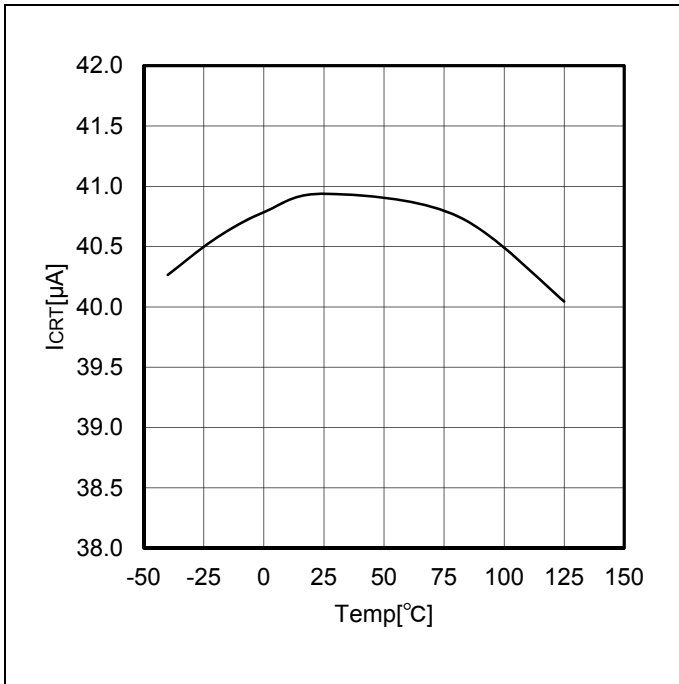

Figure 11.  $I_{CRT}$  vs Temp

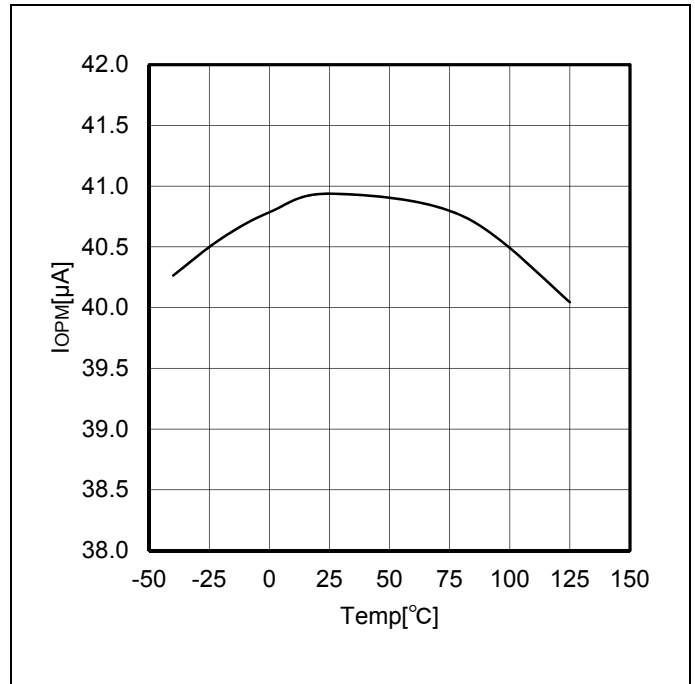

Figure 12.  $I_{OPM}$  vs Temp

**Features Description**

(Unless otherwise specified, Ta=25°C, VIN=13V, Transistor PNP = 2SAR573D, and numbers are “Typical” values.)

1. LED Current Setting

LED current I<sub>LED</sub> can be defined by setting resistances R<sub>FB1</sub> and R<sub>FB2</sub>.

$$I_{LED} = \frac{V_{FBREG}}{R_{FB1} + R_{FB2}} [A]$$

where:

V<sub>FBREG</sub> is the FB Terminal Voltage 650mV (Typ)

• How to connect LED current setting resistors

LED current setting resistors must always be connected at least in pair arranged in series as below.

**If only one current setting resistor is used, then in case of a possible resistor short, the external PNP Tr. and LED may be broken due to large current flow.**

PNP Tr. rating current, LED rating current, R<sub>FB1</sub> and R<sub>FB2</sub> must have the following relations:

$$I_{LED\_Max} > I_{PNP\_Max} > \frac{V_{FBREG}}{Min(R_{FB1}, R_{FB2})} [A]$$

where:

I<sub>LED\_Max</sub> is the LED Rating Current

I<sub>PNP\_Max</sub> is the PNP Tr. Rating Current

V<sub>FBREG</sub> is the FB Terminal Voltage 650mV(Typ)

Min(R<sub>FB1</sub>, R<sub>FB2</sub>) is the Lowest value of R<sub>FB1</sub> and R<sub>FB2</sub>

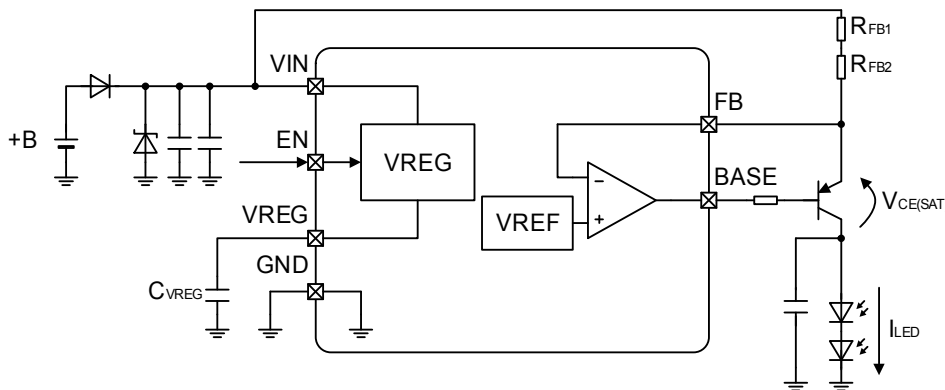

Figure 13. LED Current Setting

• Constant current control dynamic range

Constant current control dynamic range of LED current I<sub>LED</sub> can be calculated as follows.

$$V_{IN} \geq V_{f\_LED} \cdot N + V_{CE\_PNP} + V_{FBREG} [V]$$

where:

V<sub>IN</sub> is the VIN Terminal Voltage

V<sub>f\_LED</sub> is the LED Vf

N is the Number of Rows of LED

V<sub>CE(sat)</sub> is the External PNP Tr. Collector-Emitter Saturation Voltage

V<sub>FBREG</sub> is the FB Terminal Voltage 650mV(Typ)

2. Reference-Voltage (VREG)

VIN terminal generates 5.0V (Typ). This voltage is used as power source for the internal circuit, and also used to fix the voltage of terminals outside LSI to HIGH side. VREG terminal must be connected with C<sub>VREG</sub> = 1.0μF to 4.7μF to ensure capacity for the phase compensation. If C<sub>VREG</sub> is not connected, the circuit behavior would become extraordinarily unstable, for example with the oscillation of the reference-voltage.

VREG terminal voltage must not be used as power source for other devices than this LSI.

VREG circuit has a built-in UVLO function. The IC is activated when the VREG terminal voltage rises to 4.0V (Typ) or higher, and shut down when the VREG terminal voltage drops to 3.75V(Typ) or lower.

## 3. Table of Operations

The PWM dimming mode switches to DC control depending on CRT terminal voltage.

When  $V_{IN} > 22.0V$  (Typ), LED current is limited to reduce the heat dissipation of external PNP Tr.

Depending on OP/SCP terminal voltage status, output current is turned OFF. Output current is also turned OFF when Low signal is input to PBUS terminal.

In addition, UVLO, TSD further increases system reliability

For each functions, please refer to Features Description.

Operation Mode	CRT Terminal	Detecting Condition		LED Current ( $I_{LED}$ )	PBUS Terminal
		【Detect】	【Release】		
Stand-by Mode <sup>(Note1)</sup>	-	$V_{EN} \leq 0.6V$	$V_{EN} \geq 2.4V$	OFF <sup>(Note3)</sup>	Hi-Z
DC	$V_{CRT} \geq 2.0V$ (Typ)	-	-	50mA to 400mA	High (4.5V(Typ))
PWM Dimming	See Features Description, 4.	-	-	See Features Description, 4.	High (4.5V(Typ))
DC Dimming	-	$V_{DCDIM} \leq 1.0V$ (Typ)	$V_{DCDIM} > 1.25V$	See Features Description, 9.	High (4.5V(Typ))
Over Voltage Mute	-	$V_{IN} > 22.0V$ (Typ)	$V_{IN} \leq 22.0V$ (Typ)	See Features Description, 11.	High (4.5V(Typ))
LED Open Detection <sup>(Note2)</sup>	-	$V_{OP} \geq V_{IN} - 1.2V$ (Typ)	$V_{OP} < V_{IN} - 1.2V$ (Typ)	OFF <sup>(Note3)</sup>	Low
Short Circuit Protection (SCP)	-	$V_{SCP} \leq 1.2V$ (Typ)	$V_{SCP} \geq 1.25V$ (Typ)	OFF <sup>(Note3)</sup>	Low
PBUS Control OFF	-	$V_{PBUS} \leq 0.6V$	$V_{PBUS} \geq 2.4V$	OFF <sup>(Note3)</sup>	Input $V_{PBUS} \leq 0.6V$
UVLO	-	$V_{IN} \leq 4.1V$ (Typ) or $V_{REG} \leq 3.75V$ (Typ)	$V_{IN} \geq 4.5V$ (Typ) or $V_{REG} \geq 4.0V$ (Typ)	OFF <sup>(Note3)</sup>	High (4.5V(Typ))
TSD	-	$T_j \geq 175^\circ C$ (Typ)	$T_j \leq 150^\circ C$ (Typ)	OFF <sup>(Note3)</sup>	Hi-Z

(Note1) Circuit Current 0 $\mu$ A(Typ)

(Note1) In regard to the sequence of LED current OFF, see Features Description, 5.

(Note2) BASE Terminal Current: OFF, and LED Current ( $I_{LED}$ ): OFF.

4. PWM Dimming Operation using external RC network

PWM Dimming is performed with the following circuit.

The ramp up/down time of the CRT voltage, and therefore the dimming cycle and Duty, can be set by values of the external components (**C<sub>CRT</sub>**, **R<sub>CRT</sub>**).

Please connect CRT to VIN and DISC to GND or open if it is not used.

The CR timer function is activated if DC SW is OPEN. To perform PWM light control of LED current, a triangular waveform is generated at CRT terminal. The **LED current (I<sub>LED</sub>) is turned OFF** while CRT voltage is ramping up, and **LED current (I<sub>LED</sub>) is turned ON** while CRT voltage is ramping down.

When  $V_{CRT} > V_{CRT\_DIS1}$  (2.0V(Typ)), Dimming mode turns to DC Control. When  $V_{CRT} > V_{CRT\_DIS2}$  (2.4V(Typ)), discharge resistance of DISC terminal changes from  $R_{DISC1}$ (50Ω(Typ)) to  $R_{DISC2}$ (5kΩ(Typ)).

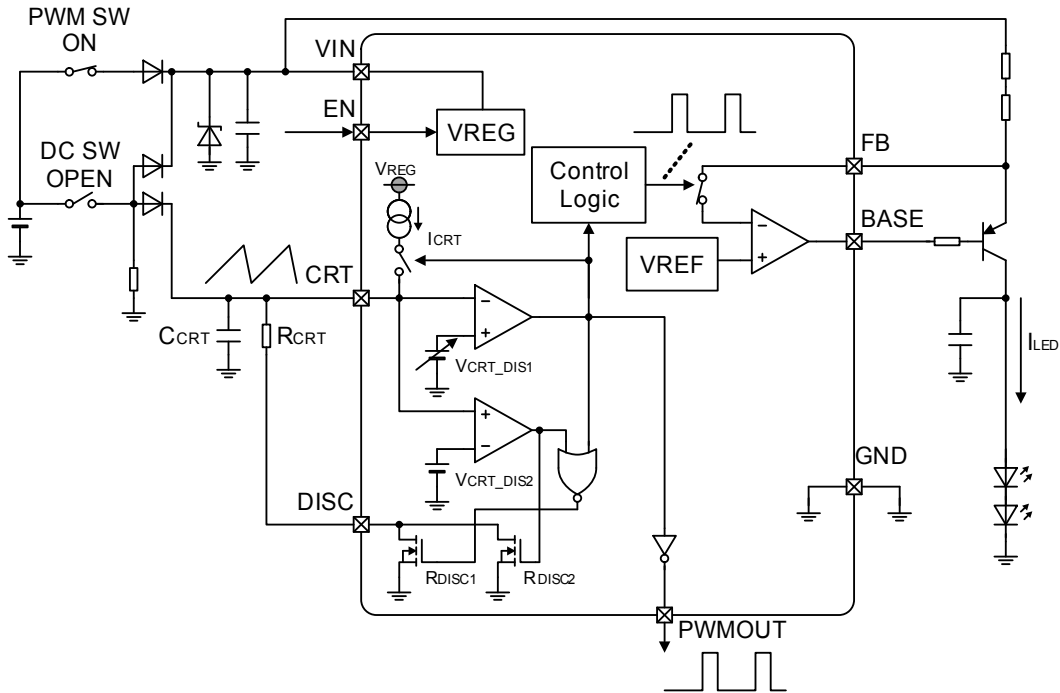

Figure 14. PWM Dimming Operation

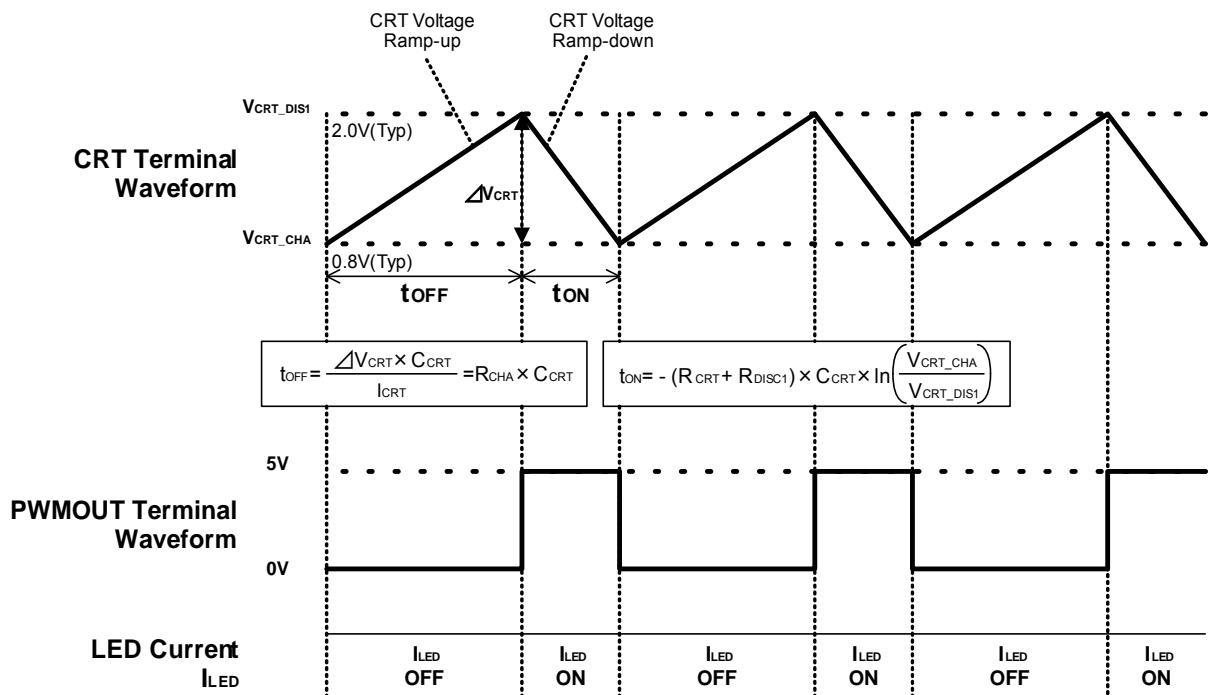

Figure 15. PWM Dimming Operation

- (1) CRT Ramp up Time  $t_{OFF}$  and CRT Ramp down Time  $t_{ON}$   
 CRT Ramp up Time  $t_{OFF}$  and CRT Ramp down Time  $t_{ON}$  can be defined from the following equations.  
 Make sure that  $t_{ON}$  is set > PWM Minimum Pulse Width  $t_{MIN}$ :10 $\mu$ s (Min).

$$t_{OFF} = \frac{\Delta V_{CRT} \times C_{CRT}}{I_{CRT}} = R_{CHA} \times C_{CRT} \text{ [S]}$$

$$t_{ON} = -(R_{CRT} + R_{DISC1}) \times C_{CRT} \times \ln\left(\frac{V_{CRT\_CHA}}{V_{CRT\_DIS1}}\right) \text{ [S]}$$

where:

$I_{CRT}$ is the CRT Terminal Charge Current	40 $\mu$ A(Typ)
$R_{CHA}$ is the CRT Terminal Charge Resistor	30k $\Omega$ (Typ)
$R_{DISC1}$ is the DISC Terminal ON Resistor1	50 $\Omega$ (Typ)
$V_{CRT\_CHA}$ is the CRT Terminal Charge Voltage	0.8V(Typ)
$V_{CRT\_DIS1}$ is the CRT Terminal Discharge Voltage1	2.0V(Typ)

- (2) PWM Dimming Frequency  $f_{PWM}$   
 PWM frequency is defined by  $t_{ON}$  and  $t_{OFF}$ .

$$f_{PWM} = \frac{1}{t_{ON} + t_{OFF}} \text{ [HZ]}$$

- (3) ON Duty( $D_{ON}$ )  
 Like the above, PWM ON duty is defined by  $t_{ON}$  and  $t_{OFF}$ .

$$D_{ON} = \frac{t_{ON}}{t_{ON} + t_{OFF}} \text{ [%]}$$

(Example) In case of  $R_{CRT}$ =3.6k $\Omega$ ,  $C_{CRT}$ =0.1 $\mu$ F (Typ)

$$t_{OFF} = R_{CHA} \times C_{CRT} = 30k\Omega \times 0.1\mu F = \mathbf{3.0ms}$$

$$t_{ON} = -(R_{CRT} + R_{DISC1}) \times C_{CRT} \times \ln(V_{CRT\_CHA} / V_{CRT\_DIS1}) = -(3.6k\Omega + 50\Omega) \times 0.1\mu F \times \ln(0.8V / 2.0V) = \mathbf{0.334ms}$$

$$f_{PWM} = 1 / (t_{ON} + t_{OFF}) = 1 / (3.0ms + 0.334ms) = \mathbf{300Hz}$$

$$D_{ON} = t_{ON} / (t_{ON} + t_{OFF}) = 0.334ms / (3.0ms + 0.334ms) = \mathbf{10.0\%}$$

**【PWM Dimming Operation using external signal】**

In case external PWM input to CRT terminal,  
 Make sure that input pulse High voltage >**2.2V** and  
 pulse Low voltage <**0.72V**.  
 Also please open DISC terminal or connect to GND.

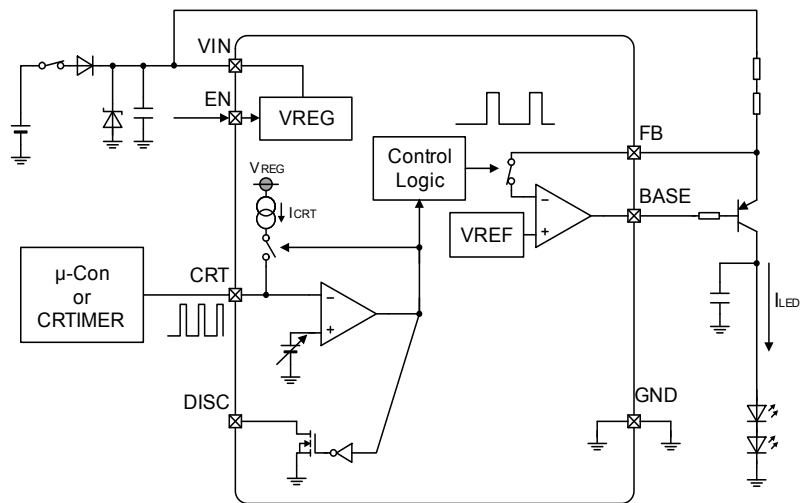

Figure 16. PWM Dimming Operation using external signal

• About a reverse connection protection diode

Caution on using Reverse protection Diode

With temperature, reverse current  $I_r$  of diode (D2, D3) can affect the charge and discharge current to capacitance C1. It is recommended to choose a diode (D2, D3) with  $I_r$  value less than  $1\mu A$ . To avoid High-Z at point A, a resistor  $R_{DCIN}$  of  $10k\Omega$  is also recommended between Point A and GND.

CRT rise / fall time deviation from set values

- ① During the PWM dimming operation mode, the A-point on Figure.17 becomes Hi-Z
  - ↓
- ② Reverse current  $I_r$  of D2 and D3 goes to the A-point  
 (Power supply voltage is being input into the cathode of D2, so reverse current of D2 goes to mainly into C1)  
 ⇒ **Reverse current  $I_r$  of D3 is added to the CRT terminal charge current and discharge current, so CRT start-up / fall time deviates from the settings.**
  - ↓
- ③ C1 gets charged, voltage at A-point rises
  - ↓
- ④ Voltage at A-point exceeds voltage in CRT terminals of each IC
  - ↓
- ⑤  $V_f$  occurs in the diodes D3
  - ↓
- ⑥ D3 circulate forward current  $I_f$   
 ⇒ **Forward current  $I_f$  of D3 is added to the CRT terminal charge current and discharge current, so CRT start-up / fall time deviates from the settings.**
  - ↓
- ⑦ Repetition ②-⑥

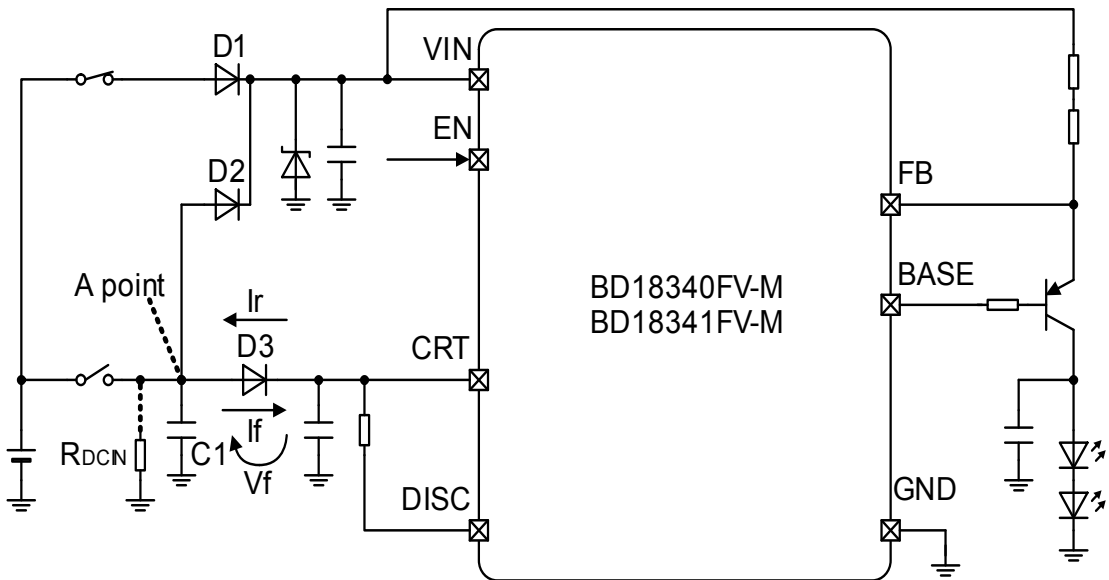

Figure 17. how reverse protection diode affects the CRT terminal rise/fall time

5. LED Open Detection Function

The IC can detect LED open condition when the OP terminal voltage ( $V_{OP}$ ) meets the following condition:  $V_{OP} > V_{IN} - 1.2V$  (Typ). As soon as  $V_{OP} > V_{IN} - 1.2V$  (Typ) condition is achieved, D terminal source current ( $230\mu A$  (Typ)) turns on and starts charging the disable LED open detection time setting capacitor ( $C_D$ ). Once the D terminal voltage ( $V_D$ ) becomes higher than  $1.0V$  (Typ) and  $1\mu s$  (Typ) elapses, the BASE terminal sink current ( $I_{BASE}$ ) is latched OFF and PBUS terminal voltage ( $V_{PBUS}$ ) is switched to Low.

**[Base Current Limit Resistance ( $R_{LIM}$ )]**

The OP terminal voltage  $V_{OP}$  is defined by the following formula:  
(Note that the external PNP Tr. goes into the saturation mode when the collector is open)

$$V_{OP} = (R_{FB1} + R_{FB2}) \times I_{BASE\_Max} + V_{CE\_PNP} [V]$$

$$I_{BASE\_Max} = 6.0V/R_{LIM} [A]$$

$$(I_{BASE\_Max} < 80mA)$$

where:

$R_{FB1}, R_{FB2}$  is the LED Current Setting Resistance

$I_{BASE\_Max}$  is the Maximum BASE Terminal Sink Current

$R_{LIM}$  is the BASE Terminal Sink Current Limit Resistance

$V_{CE\_PNP}$  is the External PNP Tr. Collector-Emitter Voltage (Note:  $I_{CE}=I_{OP}$  (23  $\mu A$  (Max)))

Please determine the BASE current limit resistance  $R_{LIM}$  to ensure that the OP terminal voltage when the LED is open should meet the following condition:  $V_{OP} > V_{IN} - 1.2V$  (Typ).

Also note that the BASE current limit resistance must meet the following condition in order to obtain the BASE current to be needed during normal LED operation.

$$4.0/R_{LIM} > I_{LED} / hfe_{MIN} [A]$$

where:

$hfe_{MIN}$  is the Minimum External PNP Tr. hfe

Disable LED open detection time  $t_D$ , or the length of time from the moment the OP terminal voltage meets the condition " $V_{OP} > V_{IN} - 1.2V$  (Typ)" until the moment the BASE terminal sink current ( $I_{BASE}$ ) is latched OFF, can be defined by the following formula. **Note that the disable time must be shorter than the ON pulse width of the PWM dimming.**

$$t_{ON} > t_D = \frac{C_D \times V_{DH}}{I_D} [s]$$

where:

$t_{ON}$  is the ON pulse width of the PWM dimming(CRT Ramp down Time)

$C_D$  is the disable LED open detection time setting capacitor

$V_{DH}$  is the D Terminal Input Threshold Voltage  $1.0V$  (Typ)

$I_D$  is the D Terminal Source Current  $230\mu A$  (Typ)

To reset the latched off LED current, EN must be turned-on again (The time when EN Terminal is "L": more than  $50\mu s$ ) or the condition " $UVLO (V_{IN} < 4.1V$  or  $V_{REG} < 3.75V)$ " must be fulfilled.

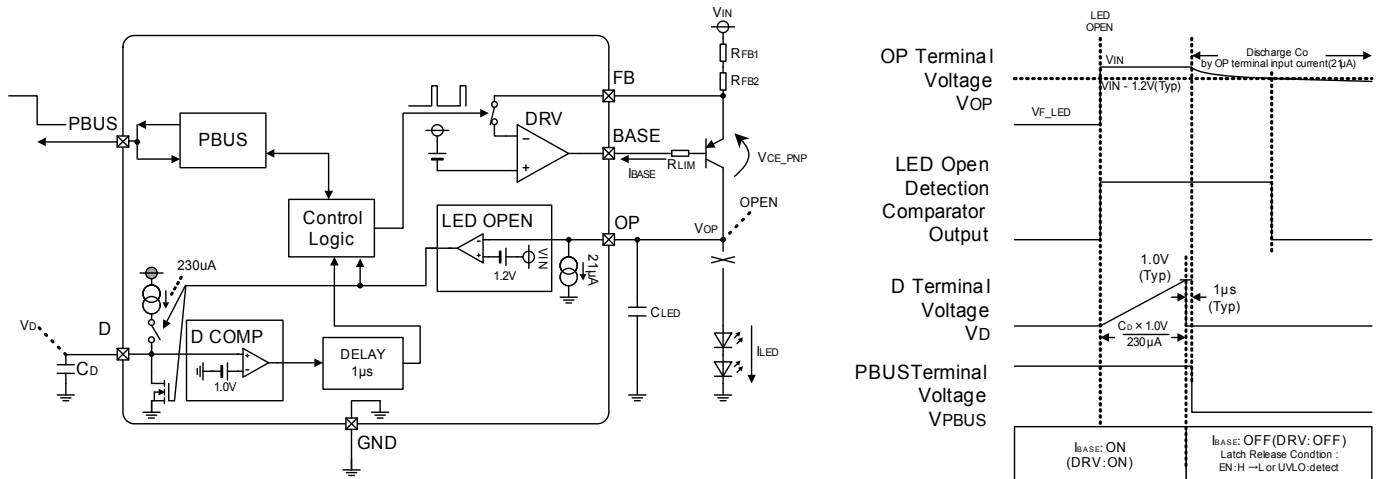

Figure 18. LED Open Detection Timing Chart



6. Disable LED Open Detection Function at Reduced-Voltage

The disable LED open detection function serves to prevent false detection of LED open at the reduced-voltage during the ramp-up/ramp-down of the VIN terminal voltage. LED open will not be detected until the VIN terminal Disable Open Detection Voltage at Reduced-Voltage (VIN\_OMP). Once VIN\_OMP is surpassed, the LED current will be latched OFF (BASE terminal sink current (IBASE) is latched OFF) and the PBUS voltage will be switched to Low following the sequence explained in Description of Functions 5.

VIN\_OMP must be defined by the following formula. (The OPM terminal voltage must be set between 1.0 V to 2.2 V.)

$$V_{IN\_OMP} \geq V_{IN\_OPERR} [V]$$

where:

VIN\_OMP is the VIN Terminal Disable Open Detection Voltage at Reduced-Voltage

VIN\_OPERR is the VIN Terminal Open Erroneous Detection Voltage at Reduced-Voltage

$$V_{IN\_OMP} = V_{OPM} \times 6.0(Typ) [V]$$

$$V_{OPM} = I_{OPM} \times R_{OPM} [V]$$

$$V_{IN\_OPERR} = V_{f\_LED} \times N + V_{OPD} [V]$$

where:

VOPM is the OPM Terminal Voltage

IOPM is the Terminal Source Current 40 μA (Typ)

ROPM is the OPM Terminal Connection Resistance

Vf\_LED is the LED Vf

N is the Number of Rows of LED

VOPD is the LED Open-Circuit Detection Voltage 1.2 V (Typ)

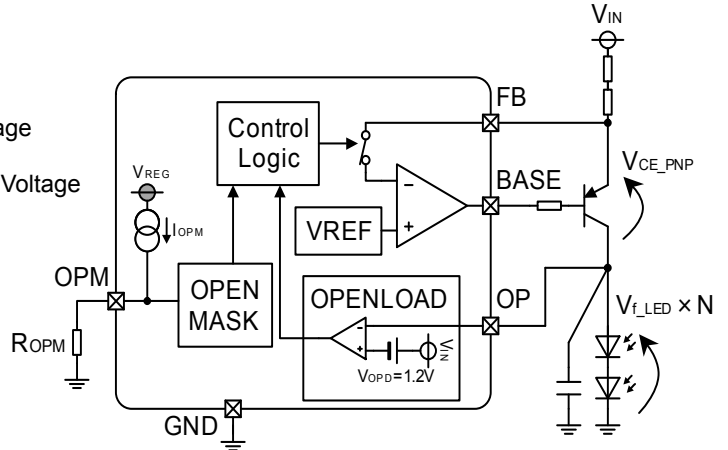

Figure 19. Disable LED Open Detection Function at Reduced-Voltage

▪ When installing heat sink resistor, or connecting resistor or diodes between OP terminal and LED anode.

When you need to install a heat sink resistor in series with the LED requiring a large amount of current in order to reduce the heat generation from the external PNP Tr, when multiple rows of the LEDs are driven, or when you connect a resistor to adjust the threshold voltage for detecting the LED open-circuit, the formula to calculate VIN\_OPERR will be different from the one above. Please read the ApplicationNote of BD1834x series for details.

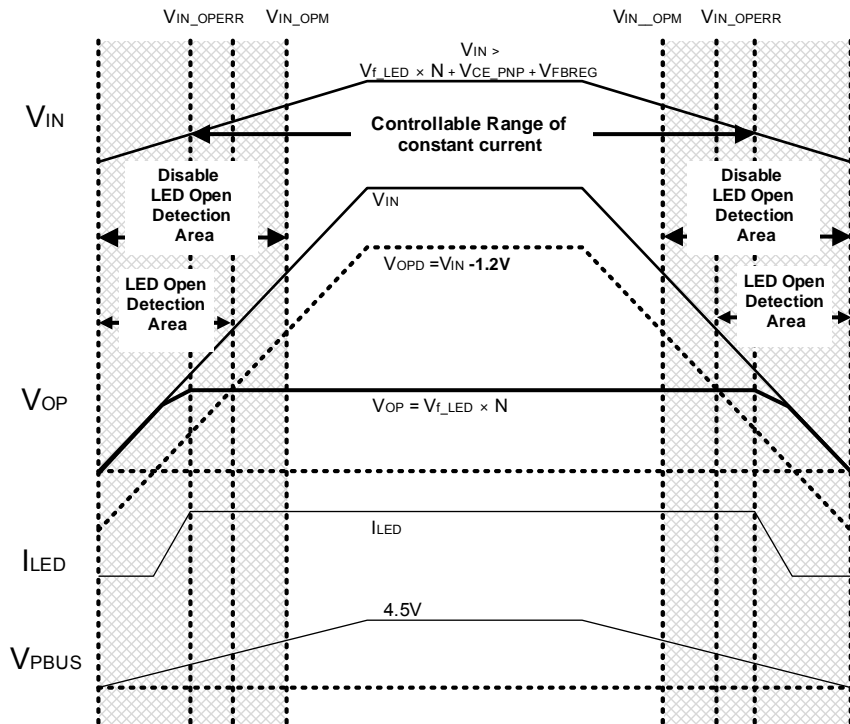

Figure 20. VIN Terminal Disable LED Open Detection Voltage and LED Open Erroneous Detection Voltage at Reduced-Voltage

7. Short Circuit Protection (SCP)

Short Circuit Protection function lowers the SCP terminal voltage when the collector of the external PNP Tr. is grounded. After a lapse of the short circuit protection delay time ( $t_{SCP}$ )(20 $\mu$ s(Typ)) following the drop of the SCP terminal voltage ( $V_{SCP}$ ) under 1.2V(Typ), the external PNP Tr. is turned OFF to prevent its thermal destruction, and the PBUS terminal is switched to Low to communicate the faulty condition.

In order to avoid malfunction, the Short Circuit Protection function will not be activated until  $V_{CRT} > 2.0$  V(Typ) after UVLO is reset.

In case where the short circuit ( $V_{SCP} < 1.2$ V(Typ)) is present from the beginning when the power is turned on, the short circuit protection function will be activated 60 $\mu$ s(Typ) after  $V_{CRT} > 2.0$ V(Typ) condition is reached.

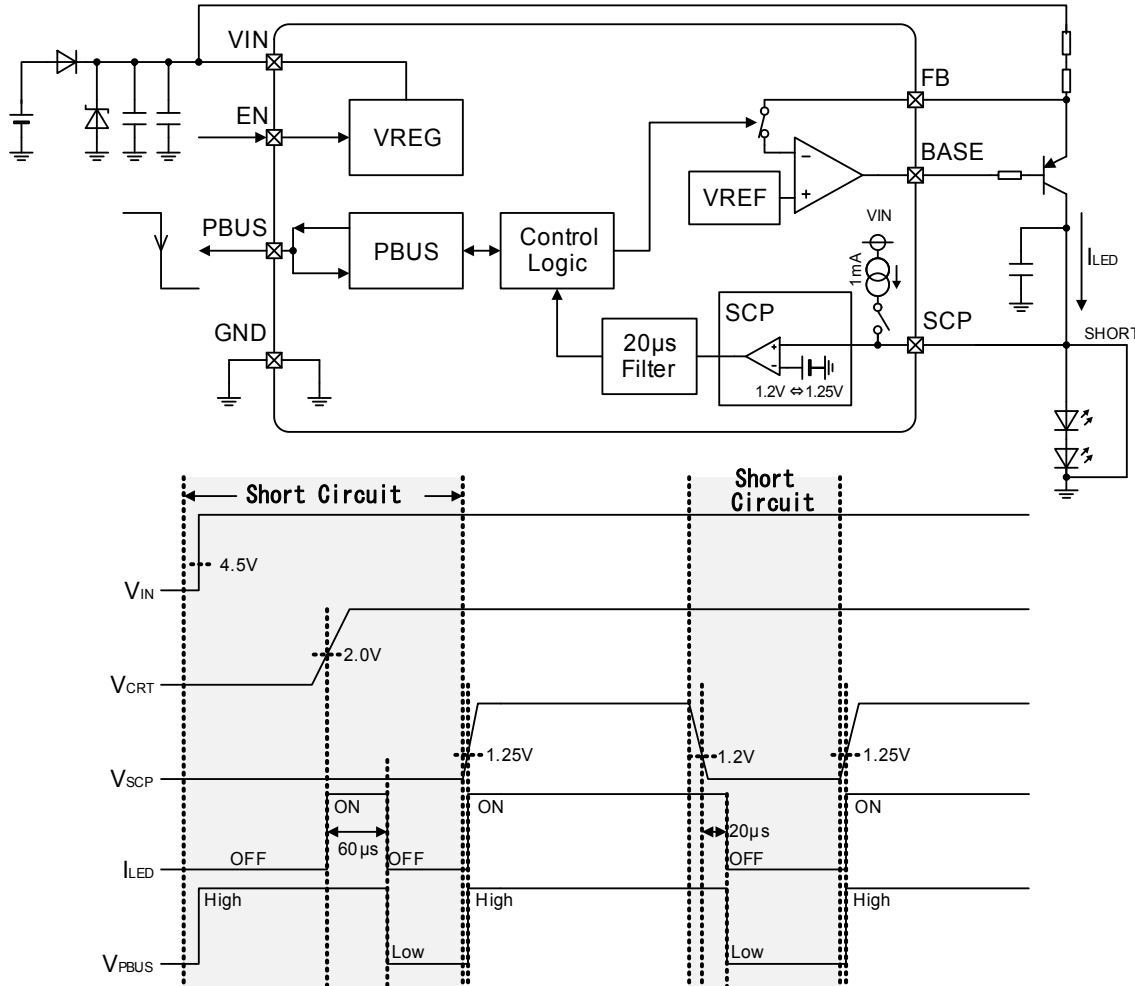

Figure 21. Short Circuit Protection (SCP)

• SCP Terminal Source Current

The SCP terminal sources the SCP terminal source current (1mA (Typ)) once its voltage ( $V_{SCP}$ ) drops under 1.3V in order to prevent the malfunction of the short circuit protection.

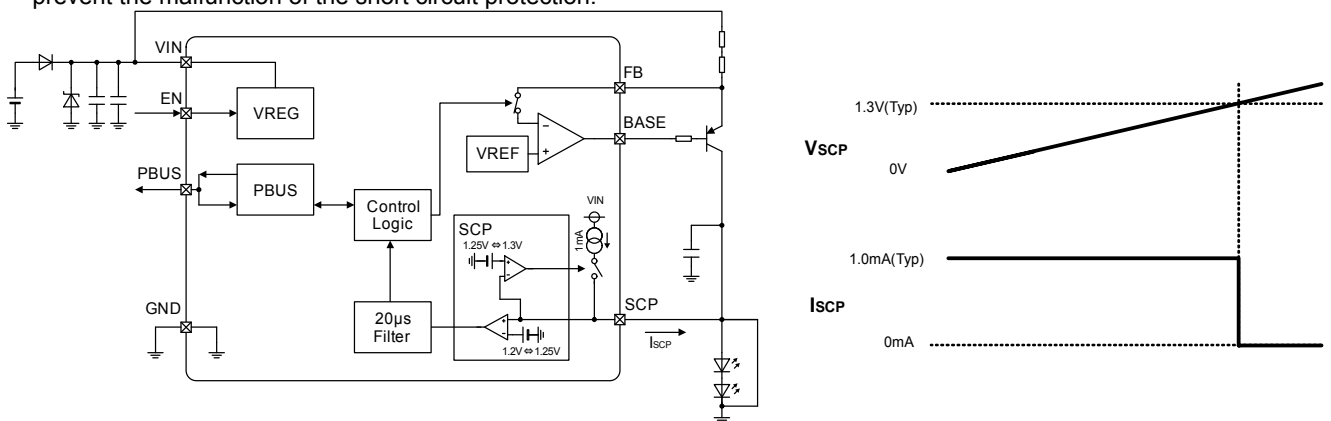

Figure 22. SCP Terminal Source Current

8. About the capacitor of connecting LED anode

During PWM Mode, the output (LED anode) will be high impedance ('Hi-Z'). During this time noise (Note1) can couple on to this pin and cause false detection of SHORT condition.

To prevent this it is necessary to connect a Capacitor (0.1μF to 0.68μF) between LED anode and GND terminal nearby terminal

(Note1) Conducted noise, Radiated noise, Crosstalk of connector and PCB pattern etc...

Make sure that the capacitor of connecting LED anode is the following equation:

$$0.1 \leq C_{LED} \leq 0.68 [\mu F]$$

In case above range is exceeded, the I<sub>LED</sub> current becomes dull, so please evaluate I<sub>LED</sub> waveform in PWM mode operation. (Please refer to the following waveform).

About the example of evaluation, please see to the following waveform.

In case a capacitor exceeding the recommended range (above 0.68μF) is connected to LED anode, there is a possibility that delay time of start-up will reach about several decades ms, so special attention is needed.

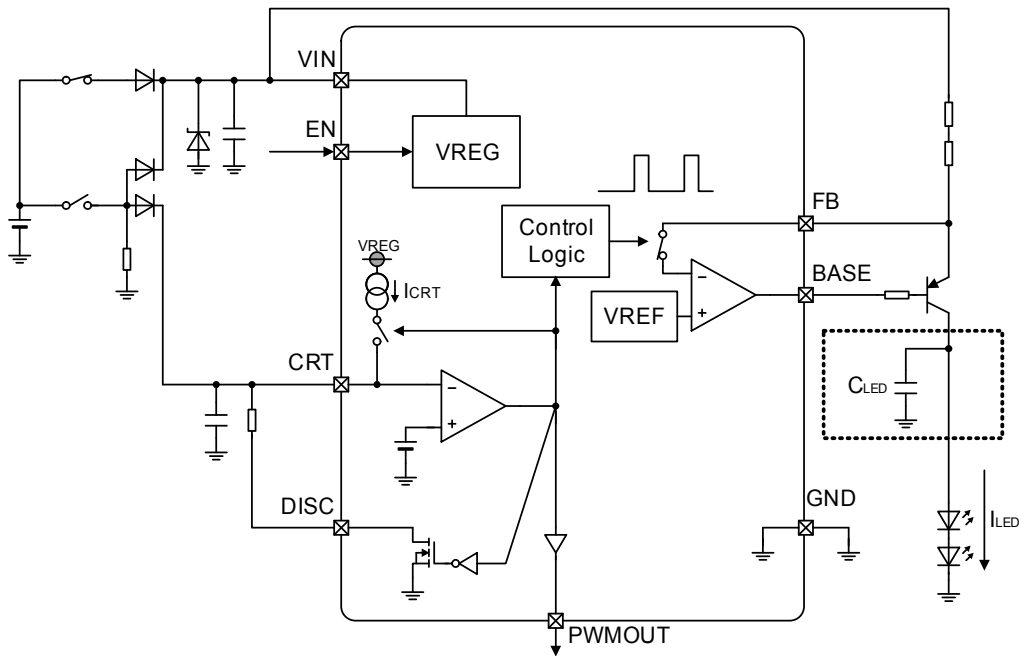

Figure 23. About the capacitor of connecting LED anode

Evaluation example (ILED pulse width at PWM Dimming operation)

Condition: +B = 13V  
 Ta = 25°C  
 LED = 1 Strings  
 CCRT = 0.01μF  
 RDISC = 1.0kΩ  
 PWM Dimming Mode

PNP Tr. : 1parallel	ILED=50mA	ILED=500mA
CLED=0.1μF		
	Rise Time: 2.0μs Fall Time: 0.9μs OverShoot: ≈ 0mA	Rise Time: 1.9μs Fall Time: 0.7μs OverShoot: 1mA (0.2%)
CLED=0.47μF		
	Rise Time: 7.4μs Fall Time: 5.3μs OverShoot: ≈ 0mA	Rise Time: 4.4μs Fall Time: 2.5μs OverShoot: ≈ 0mA
PNP Tr. : 5parallel	ILED=50mA	ILED=200mA
CLED=0.1μF		
	Rise Time: 1.5μs Fall Time: 0.6μs OverShoot: 22mA (4.4%)	Rise Time: 2.2μs Fall Time: 0.5μs OverShoot: 10mA (1%)
CLED=0.47μF		
	Rise Time: 2.8μs Fall Time: 1.4μs OverShoot: ≈ 0mA	Rise Time: 2.4μs Fall Time: 0.8μs OverShoot: 56mA (5.6%)

9. LED Current De-rating Function (DC Dimming Function)

The LED current ( $I_{LED}$ ) will be cut down once the DCDIM terminal voltage goes under 1.0 V (Typ).

If LED de-rating function is not used, please DCDIM terminal must be kept below 1.25V always and as stable as possible. Any ripples at DCDIM terminal will cause oscillations in output current  $I_{LED}$ . It is recommended to insert a capacitor at DCDIM terminal.

**Steep changes in the DCDIM terminal voltage also might affect the ability of the output amplifier to keep up with the changes. So Please evaluate  $I_{LED}$  waveform on actual board.**

The LED current de-rating function can be defined by the following formula:

$$V_{DCDIM} = V_{REG} \cdot \frac{R_{NTC}}{R_{NTC} + R_{DCDIM}} \quad [V]$$

$$V_{FBREG} (V_{DCDIM} < 1.0V) = V_{FBREG} - (1.0V - V_{DCDIM}) \times D_{DG} \quad [V]$$

where:

$R_{DCDIM}$  is The Resistor for setting DC Dimming

$R_{NTC}$  is the NTC Thermistor Resistance

$V_{FBREG}$  is the FB Terminal Voltage  $V_{IN} - 650 \text{ mV}$  (Typ)

$D_{DG}$  is the DCDIM Dimming Gain 725 mV/V (Typ)

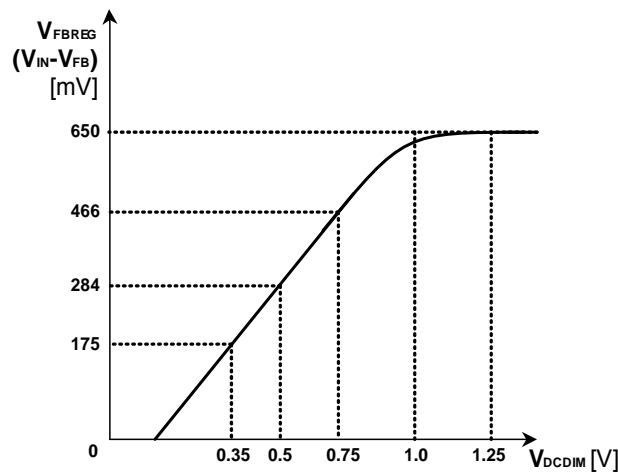
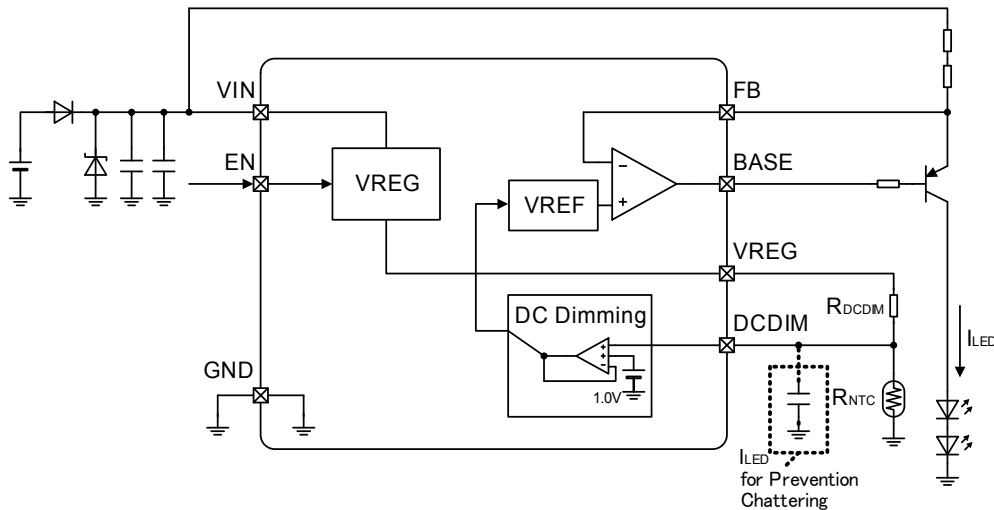

Figure 24. LED Current De-rating Function (DC Dimming Function)

10. PBUS Function

The PBUS terminal has two functions. When the IC detects OPEN/SHORT of LED's the PBUS is pulled LOW. It is also possible to turn OFF  $I_{LED}$  current by externally pulling the PBUS to LOW voltage. This feature is useful when multiple this IC's are used to drive LED loads. An OPEN/SHORT detection by one IC can be used to turn OFF current of other driver IC's. (Please refer connection diagram below)

**Caution of using PBUS terminal**

**Always connect only PBUS terminal of BD18340 and BD18341 IC's. Interconnection with other family products does not guarantee proper operating conditions**

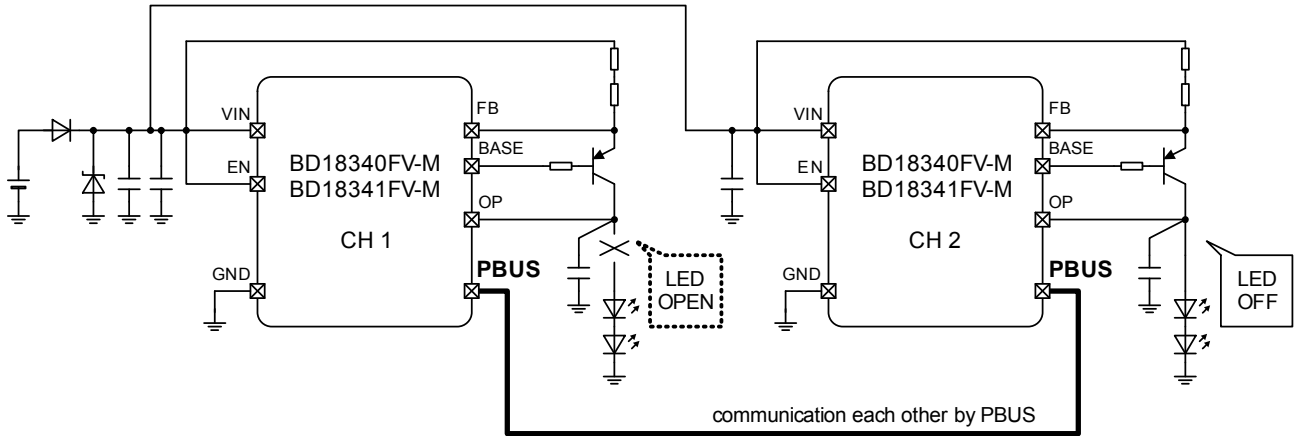

Figure 25. PBUS Function

▼Example of Protective Operation due to LED Open Circuit

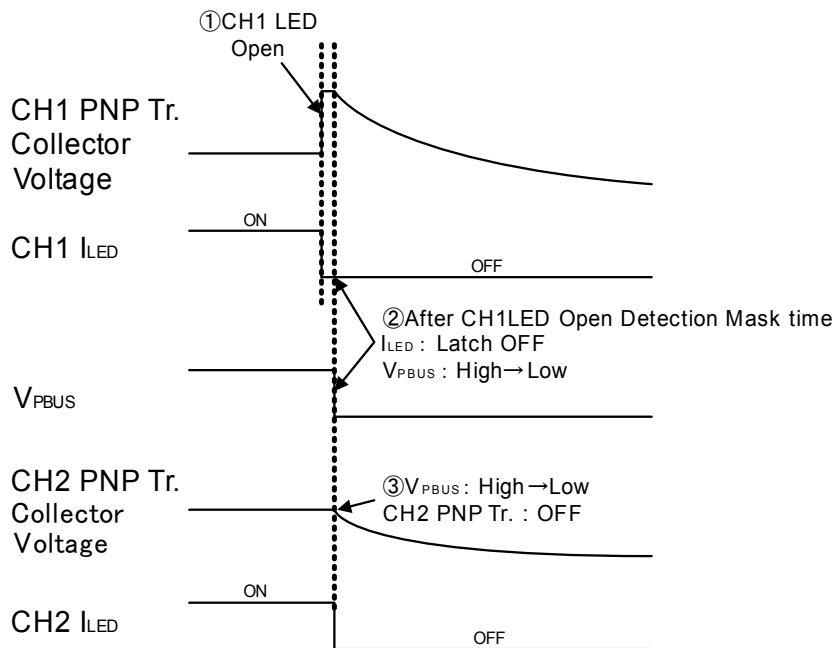

Figure 26. Example of Protective Operation

If LED OPEN occurs, PBUS of CH1 is switched from Hi-Z to Low output. As PBUS becomes Low, LED drivers of other CH detect the condition and turns OFF their own LEDs. LED anode clamps to 1.3V (Typ) during the OFF period, in order to prohibit ground fault detection.

11. Over Voltage Mute Function (OVM)

Once the VIN terminal voltage (VIN) goes above 22.0 V (Typ), the over voltage mute function is activated to decrease the LED current (ILED) in order to suppress heat generation from the external PNP Tr. The FB terminal voltage VFBREG which controls the LED current (ILED) will decay at -25 mV/V (Typ).

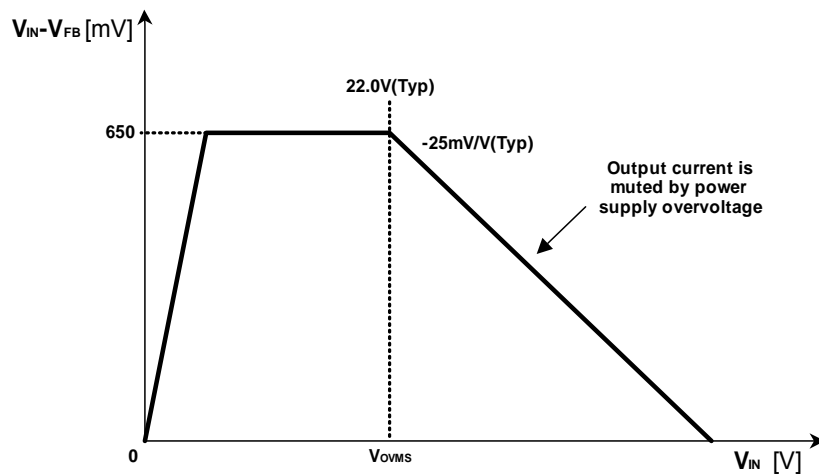
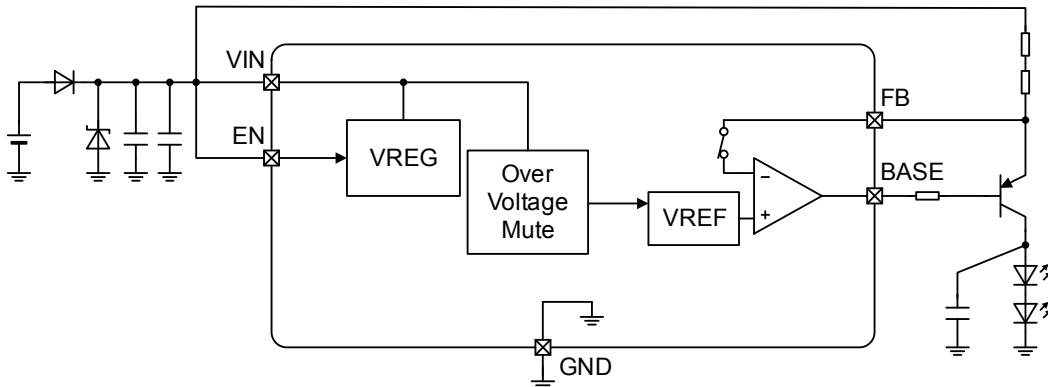

Figure 27. Overvoltage Mute Function (OVM)

12. Under voltage Lockout (UVLO)

UVLO is a protection circuit to prevent malfunction of the IC when the power is turned on or then the power is suddenly shut off.

This IC has two UVLO circuits; UVLO VIN for VIN and UVLO VREG for VREG.

As soon as UVLO status is detected, BASE terminal sink current will be turned off to switch OFF the LED current (ILED).

The following shows the threshold conditions of both UVLO circuits.

Operating Mode	Detection Conditions		LED Current (ILED)	PBUS Terminal
	[Detect]	[Release]		
UVLO VIN	VIN ≤ 4.1 V(Typ)	VIN ≥ 4.5 V(Typ)	OFF(Not1)	High output (4.5 V (Typ))
UVLO VREG	VREG ≤ 3.75V(Typ)	VREG ≥ 4.0 V(Typ)	OFF(Not1)	High output (4.5 V (Typ))

(Note 1) BASE terminal sink current is turned OFF to switch OFF the LED current ILED.

**Timing Chart**

(Unless otherwise specified Ta=25°C, VIN=13V, Transistor PNP=2SAR573D, LED2strings, Value is Typical.)

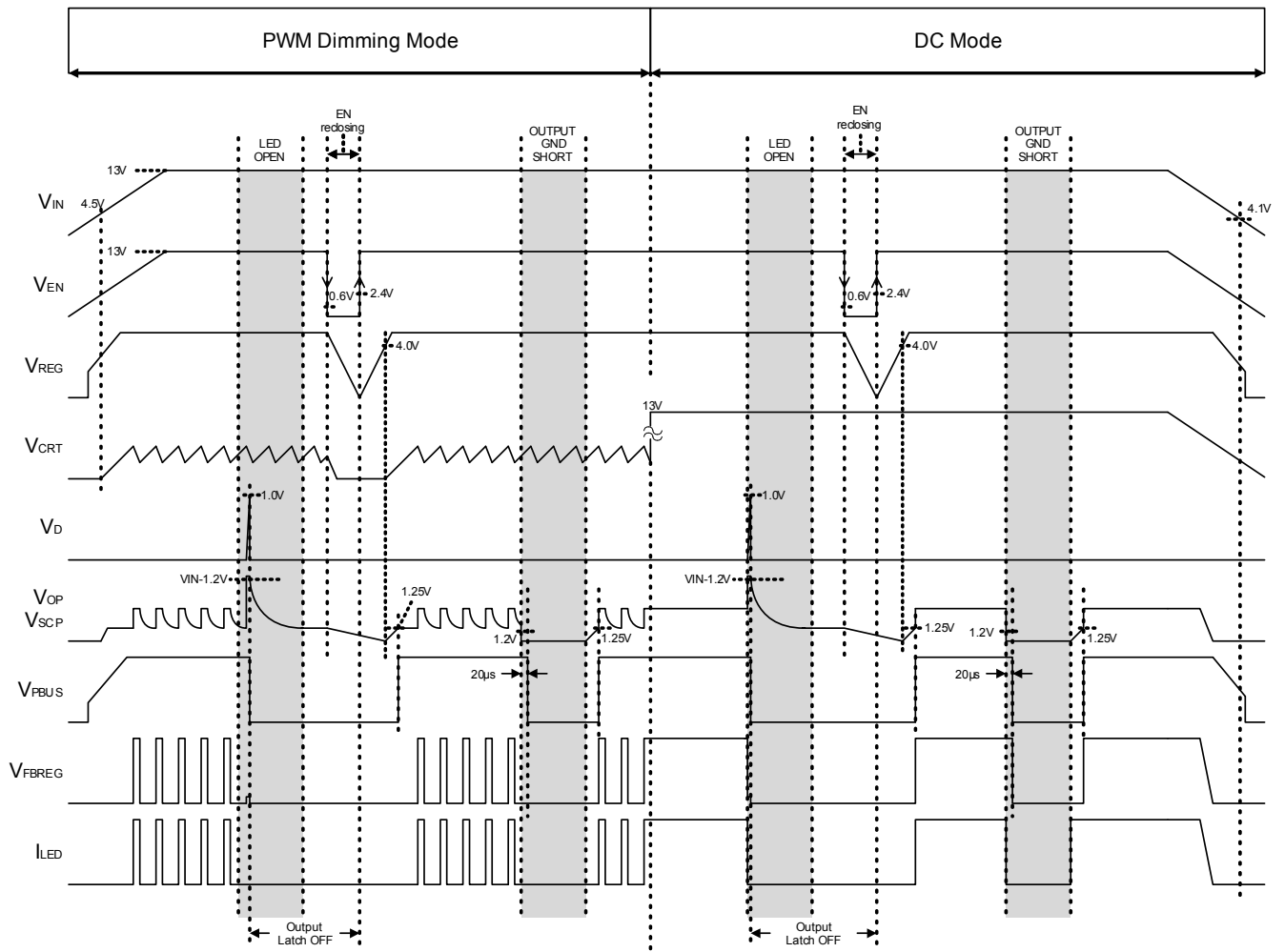

Figure 28. Timing Chart



Recommended Application Circuit

(1) I<sub>LED</sub>=120mA

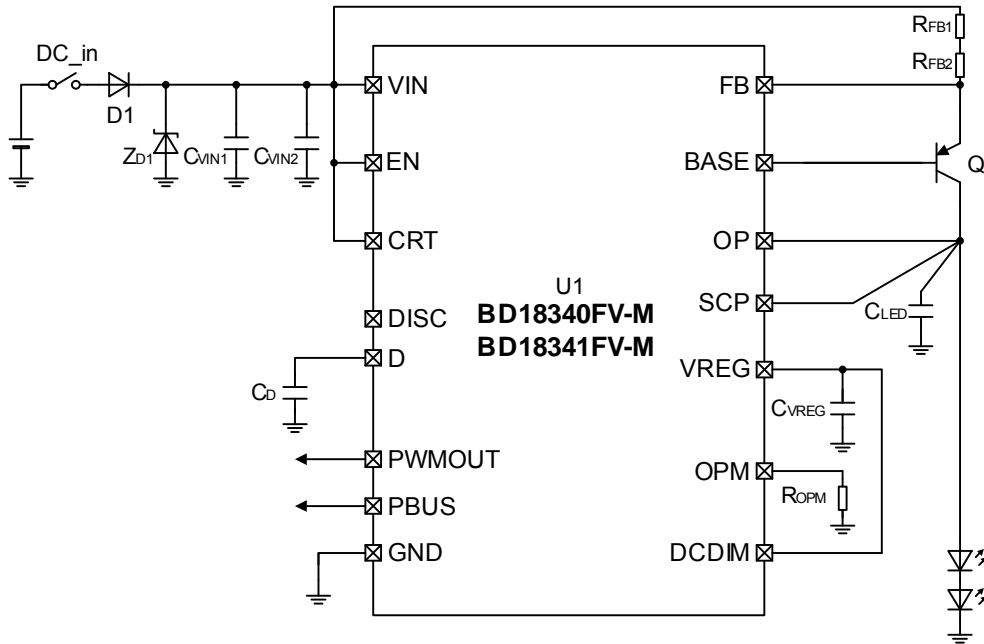

Figure 29. Recommended Application Circuit1 (I<sub>LED</sub> 120mA, LED white 2strings)

Recommended Parts List1 (I<sub>LED</sub> 120mA, LED white 2strings)

Parts	No	Parts Name	Value	UNIT	Product Maker
IC	U1	BD18340FV-M/BD18341FV-M	-	-	ROHM
Diode	D1	RFN2L6S	-	-	ROHM
	Z <sub>D1</sub>	TNR12H-220K	-	-	NIPPON CHEMICON
PNP Tr.	Q1	2SAR573D	-	-	ROHM
Resistor	R <sub>FB1</sub>	LTR10 Series	2.7	Ω	ROHM
	R <sub>FB2</sub>	LTR10 Series	2.7	Ω	ROHM
	R <sub>OPM</sub>	MCR03 Series	39	kΩ	ROHM
Capacitor	C <sub>VIN1</sub>	GCM32ER71H475KA40	4.7	μF	murata
	C <sub>VIN2</sub>	GCM188R11H104KA42	0.1	μF	murata
	C <sub>VREG</sub>	GCM188R71E105KA49	1.0	μF	murata
	C <sub>D</sub>	GCM188R11H103KA01	0.01	μF	murata
	C <sub>LED</sub>	GCM188R11H104KA42	0.1	μF	murata

(About Z<sub>D1</sub>, please place according to Test Standard of Battery line.)

Please note the following

1. External PNP transistor

For external PNP transistor, please use the recommended device 2SAR573D for this IC.

While using non-recommended device, validate the design on actual board.

Please check hfe of the part to design base current limit resistor. (See Features Description, section 5). As for parasitic capacitance (C<sub>LED</sub> connected at LED anode), The more it is small overshoot will be smaller. Please use devices that parasitic capacitance smaller than recommended device, also parasitic capacitance is possible to variation by PCB layout.

So please evaluate over shoot of I<sub>LED</sub> on actual board. (See Features Description, Section 8 -Evaluation example, ILED pulse width at PWM Dimming operation).

2. Power supply steep variation

This IC is validated with test conditions as per ISO7637-2 standards.

There is possibility of unexpected LED regulation due to sudden transients outside the specification range standards in input power supply. Please check the maximum ratings of LED and evaluate on actual board for any unexpected LED regulation.

(2) ILED=120mA, PWM ON Duty=10%

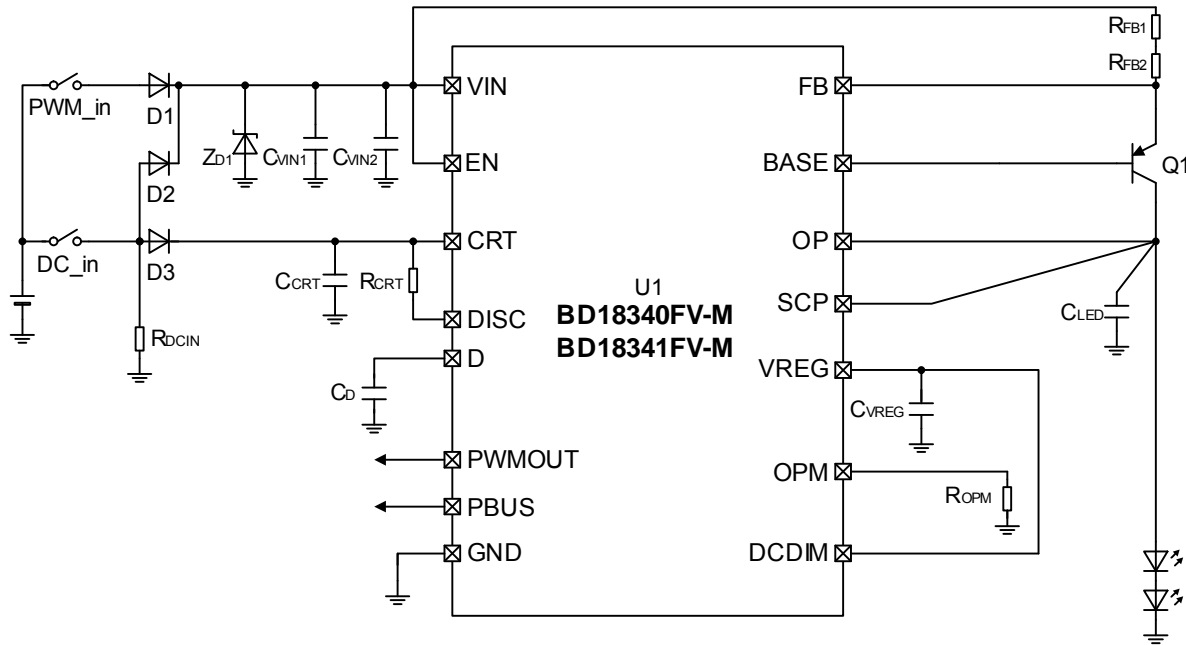

Figure 30. Recommended Application Circuit 2  
 (ILED 120mA , LED white 2strings, PWM ON Duty: 10%(Pulse width : 0.334ms), PWM frequency : 300Hz)

**Recommended Parts List 2**

(ILED 120mA, LED white 2strings, PWM ON Duty: 10%(Pulse width: 0.334ms),PWM frequency: 300Hz)

Parts	No	Parts Name	Value	UNIT	Product Maker
IC	U1	BD18340FV-M/BD18341FV-M	-	-	ROHM
Diode	D1,D2	RFN2L6S	-	-	ROHM
	D3	RFN1L6S	-	-	ROHM
	ZD1	TNR12H-220K	-	-	NIPPON CHEMICON
PNP Tr.	Q1	2SAR573D	-	-	ROHM
Resistor	RFB1	LTR10 Series	2.7	Ω	ROHM
	RFB2	LTR10 Series	2.7	Ω	ROHM
	RCRT	MCR03 Series	3.6	kΩ	ROHM
	ROPM	MCR03 Series	39	kΩ	ROHM
	RDCIN	ESR10 Series	2	kΩ	ROHM
Capacitor	CVIN1	GCM32ER71H475KA40	4.7	μF	murata
	CVIN2	GCM188R11H104KA42	0.1	μF	murata
	CVREG	GCM188R71E105KA49	1.0	μF	murata
	CCRT	GCM188R11H104KA42	0.1	μF	murata
	CD	GCM188R11H103KA01	0.01	μF	murata
	CLED	GCM188R11H104KA42	0.1	μF	murata

(About ZD1, please place according to Test Standard of Battery line.)

(3) ILED=524mA, PWM ON Duty=10%, LED Current De-rating function

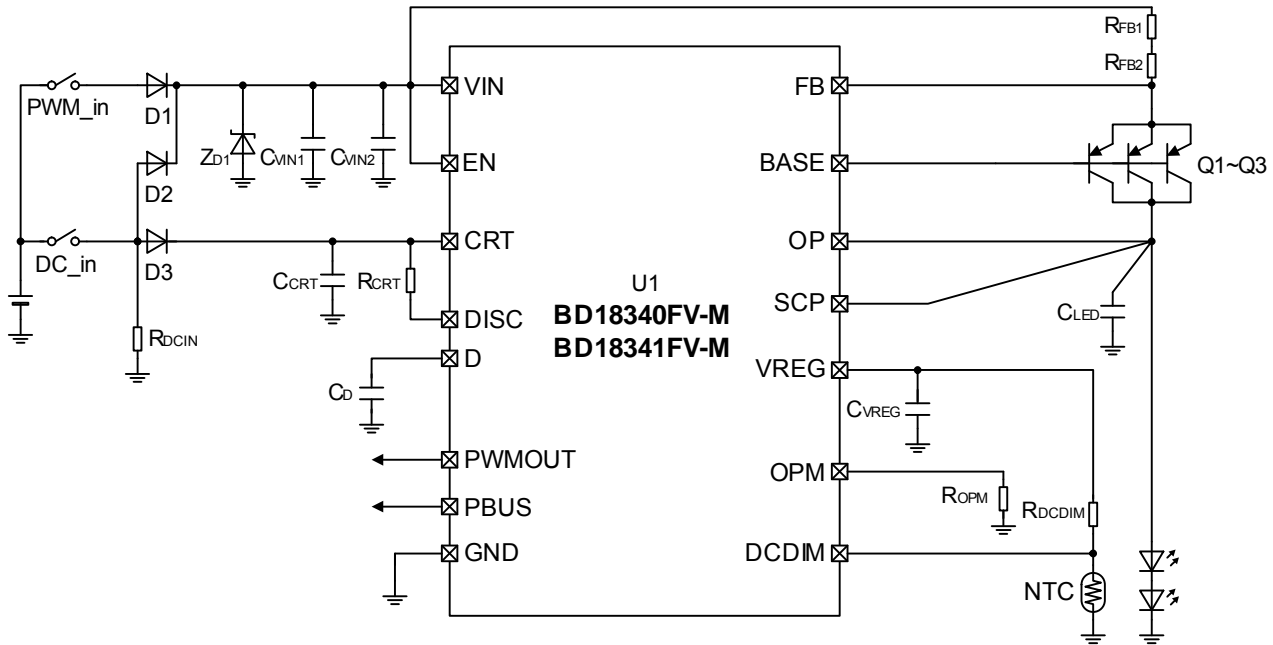

Figure 31. Recommended Application Circuit 3  
 (I<sub>LED</sub> 524mA, LED white 2strings, PWM ON Duty : 10%(pulse width : 0.334ms), PWM frequency : 300Hz)

**Recommended Parts List 3**

(I<sub>LED</sub> 524mA, LED white 2strings, PWM ON Duty : 10%(pulse width : 0.334ms), PWM frequency : 300Hz)

Parts	No	Parts Name	Value	Unit	Product Maker
IC	U1	BD18340FV-M/BD18341FV-M	-	-	ROHM
Diode	D1,D2	RFN2L6S	-	-	ROHM
	D3	RFN1L6S	-	-	ROHM
	Z <sub>D1</sub>	TNR12H-220K	-	-	NIPPON CHEMICON
PNP Tr.	Q1 to Q3	2SAR573D	-	-	ROHM
Resistor	R <sub>FB1</sub>	LTR10 Series	0.62	Ω	ROHM
	R <sub>FB2</sub>	LTR10 Series	0.62	Ω	ROHM
	R <sub>CRT</sub>	MCR03 Series	3.6	kΩ	ROHM
	R <sub>OPM</sub>	MCR03 Series	39	kΩ	ROHM
	R <sub>D1CDIM</sub>	MCR03 Series	43	kΩ	ROHM
	NTC	NTCG104LH154H	150	kΩ	TDK
	R <sub>D1CIN</sub>	ESR10 Series	2	kΩ	ROHM
Capacitor	C <sub>VIN1</sub>	GCM32ER71H475KA40	4.7	μF	murata
	C <sub>VIN2</sub>	GCM188R11H104KA42	0.1	μF	murata
	C <sub>VREG</sub>	GCM188R71E105KA49	1.0	μF	murata
	C <sub>CRT</sub>	GCM188R11H104KA42	0.1	μF	murata
	C <sub>D</sub>	GCM188R11H103KA01	0.01	μF	murata
	C <sub>LED</sub>	GCM188R11H104KA42	0.1	μF	murata

(About Z<sub>D1</sub>, please place according to Test Standard of Battery line.)

(4) ILED=150mA、Three rows drive、PWM ON Duty=10%、LED Current De-rating function

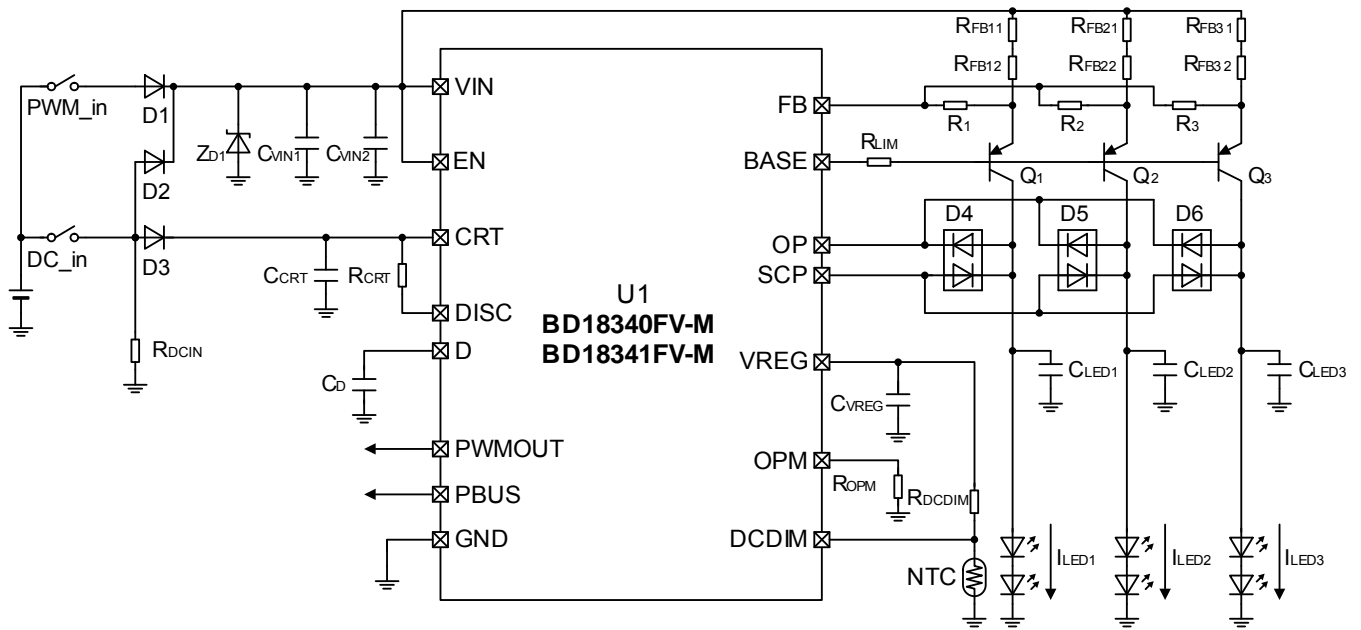

Figure 32. Recommended Application Circuit 4

(ILED1~3 150mA、LED white 2strings × 3、PWM ON Duty : 10%( pulse width : 0.334ms)、PWM frequency : 300Hz)

Please refer to Application Note , about detail the above recommended BD1834x series Application circuit 4

**Thermal Loss**

Thermal design should meet the following equation:

$$P_d > P_c$$

$$P_d = (1/\theta_{JA}) \cdot (T_{jmax} - T_a) \text{ or } (1/\Psi_{JT}) \cdot (T_{jmax} - T_T)$$

$$P_c = V_{IN} \cdot I_{VIN2} + V_{BASE} \cdot I_{BASE}$$

where:

$P_d$  is the Power Dissipation

$P_c$  is the Power Consumption

$V_{IN}$  is the VIN Terminal Voltage

$I_{VIN2}$  is the Circuit Current at Normal Mode

$V_{BASE}$  is the BASE Terminal Voltage

$I_{BASE}$  is the BASE Terminal Sink Current

$\theta_{JA}$  is the Thermal Resistance of Junction to Ambient

$\Psi_{JT}$  is the thermal Characterization Parameter of Junction to centerCase Surface

$T_{jmax}$  is the Max Joint Temperature (150 °C)

$T_a$  is the Ambient Temperature

$T_T$  is the Case Surface Temperature

I/O equivalence circuits

No.	Terminal Name	I/O Equivalent Circuit	No.	Terminal Name	I/O Equivalent Circuit
1	FB (1Pin)		9	OPM (9Pin)	
2	BASE (2Pin)		10	VREG (10Pin)	
3	N.C		11	DCDIM (11Pin)	
4	OP (4Pin)		12	D (12Pin)	
5	SCP (5Pin)		13	CRT (13Pin)	
6	GND	-	14	DISC (14Pin)	
7	PBUS (7Pin)		15	EN (15Pin)	
8	PWM OUT (8Pin)		16	VIN	-

## Operational Notes

### 1. Reverse Connection of Power Supply

Connecting the power supply in reverse polarity can damage the IC. Take precautions against reverse polarity when connecting the power supply, such as mounting an external diode between the power supply and the IC's power supply pins.

### 2. Power Supply Lines

Design the PCB layout pattern to provide low impedance supply lines. Furthermore, connect a capacitor to ground at all power supply pins. Consider the effect of temperature and aging on the capacitance value when using electrolytic capacitors.

### 3. Ground Voltage

Ensure that no pins are at a voltage below that of the ground pin at any time, even during transient condition.  
OR

### 4. Ground Wiring Pattern

When using both small-signal and large-current ground traces, the two ground traces should be routed separately but connected to a single ground at the reference point of the application board to avoid fluctuations in the small-signal ground caused by large currents. Also ensure that the ground traces of external components do not cause variations on the ground voltage. The ground lines must be as short and thick as possible to reduce line impedance.

### 5. Thermal Consideration

Should by any chance the maximum junction temperature rating be exceeded the rise in temperature of the chip may result in deterioration of the properties of the chip. In case of exceeding this absolute maximum rating, increase the board size and copper area to prevent exceeding the maximum junction temperature rating.

### 6. Recommended Operating Conditions

These conditions represent a range within which the expected characteristics of the IC can be approximately obtained. The electrical characteristics are guaranteed under the conditions of each parameter.

### 7. Inrush Current

When power is first supplied to the IC, it is possible that the internal logic may be unstable and inrush current may flow instantaneously due to the internal powering sequence and delays, especially if the IC has more than one power supply. Therefore, give special consideration to power coupling capacitance, power wiring, width of ground wiring, and routing of connections.

### 8. Operation Under Strong Electromagnetic Field

Operating the IC in the presence of a strong electromagnetic field may cause the IC to malfunction.

### 9. Testing on Application Boards

When testing the IC on an application board, connecting a capacitor directly to a low-impedance output pin may subject the IC to stress. Always discharge capacitors completely after each process or step. The IC's power supply should always be turned off completely before connecting or removing it from the test setup during the inspection process. To prevent damage from static discharge, ground the IC during assembly and use similar precautions during transport and storage.

## Operational Notes – continued

**10. Inter-pin Short and Mounting Errors**

Ensure that the direction and position are correct when mounting the IC on the PCB. Incorrect mounting may result in damaging the IC. Avoid nearby pins being shorted to each other especially to ground, power supply and output pin. Inter-pin shorts could be due to many reasons such as metal particles, water droplets (in very humid environment) and unintentional solder bridge deposited in between pins during assembly to name a few.

**11. Unused Input Pins**

Input pins of an IC are often connected to the gate of a MOS transistor. The gate has extremely high impedance and extremely low capacitance. If left unconnected, the electric field from the outside can easily charge it. The small charge acquired in this way is enough to produce a significant effect on the conduction through the transistor and cause unexpected operation of the IC. So unless otherwise specified, unused input pins should be connected to the power supply or ground line.

**12. Regarding the Input Pin of the IC**

This monolithic IC contains P+ isolation and P substrate layers between adjacent elements in order to keep them isolated. P-N junctions are formed at the intersection of the P layers with the N layers of other elements, creating a parasitic diode or transistor. For example (refer to figure below):

When  $GND > Pin A$  and  $GND > Pin B$ , the P-N junction operates as a parasitic diode.  
When  $GND > Pin B$ , the P-N junction operates as a parasitic transistor.

Parasitic diodes inevitably occur in the structure of the IC. The operation of parasitic diodes can result in mutual interference among circuits, operational faults, or physical damage. Therefore, conditions that cause these diodes to operate, such as applying a voltage lower than the GND voltage to an input pin (and thus to the P substrate) should be avoided.

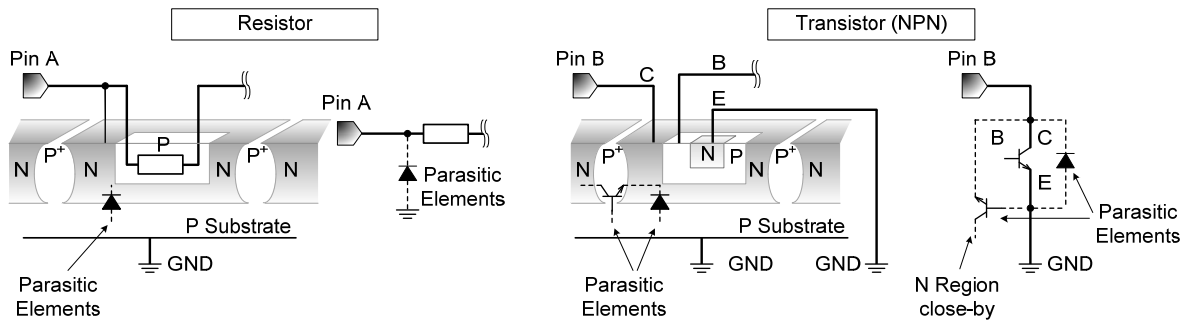

Figure 33. Example of monolithic IC structure

**13. Ceramic Capacitor**

When using a ceramic capacitor, determine the dielectric constant considering the change of capacitance with temperature and the decrease in nominal capacitance due to DC bias and others.

**14. Area of Safe Operation (ASO)**

Operate the IC such that the output voltage, output current, and the maximum junction temperature rating are all within the Area of Safe Operation (ASO).

**15. Thermal Shutdown Circuit(TSD)**

This IC has a built-in thermal shutdown circuit that prevents heat damage to the IC. Normal operation should always be within the IC's maximum junction temperature rating. If however the rating is exceeded for a continued period, the junction temperature ( $T_j$ ) will rise which will activate the TSD circuit that will turn OFF all output pins. When the  $T_j$  falls below the TSD threshold, the circuits are automatically restored to normal operation.

Note that the TSD circuit operates in a situation that exceeds the absolute maximum ratings and therefore, under no circumstances, should the TSD circuit be used in a set design or for any purpose other than protecting the IC from heat damage.



Ordering Information

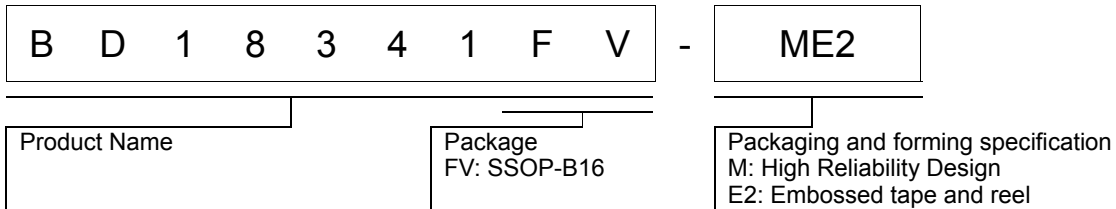
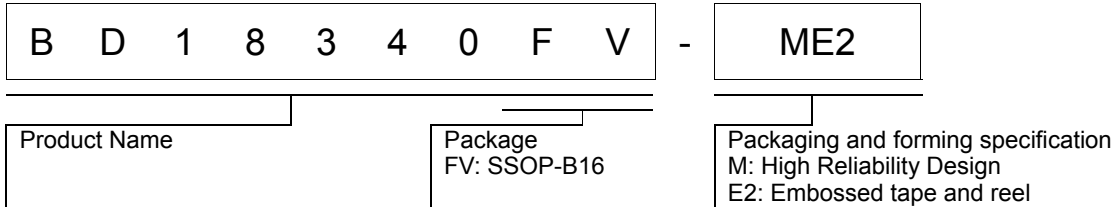

Marking Diagrams

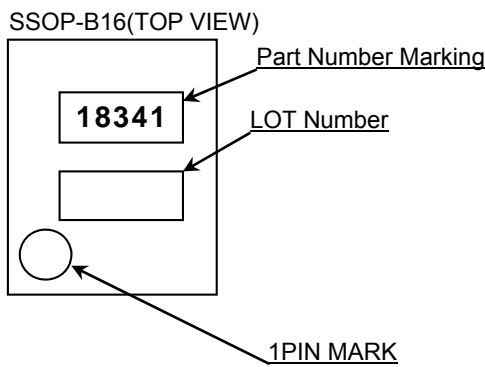
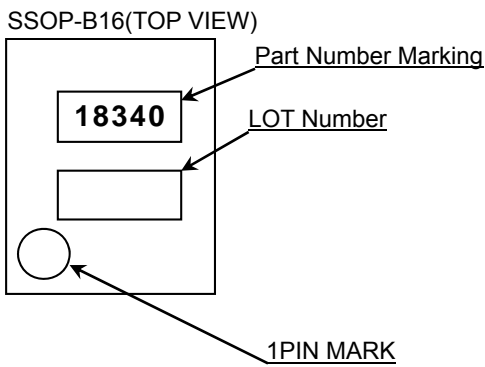

Physical Dimension, Tape and Reel Information

Package Name	SSOP-B16
--------------	----------

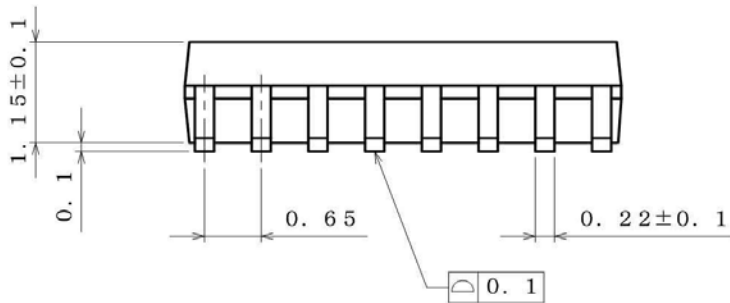
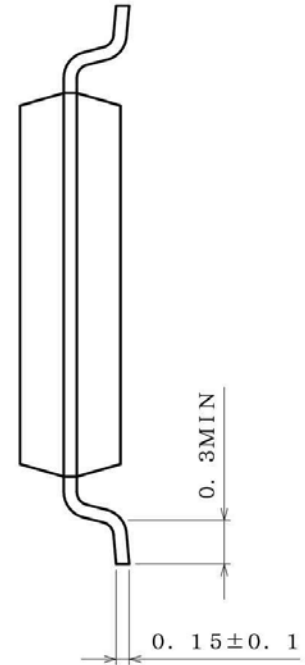
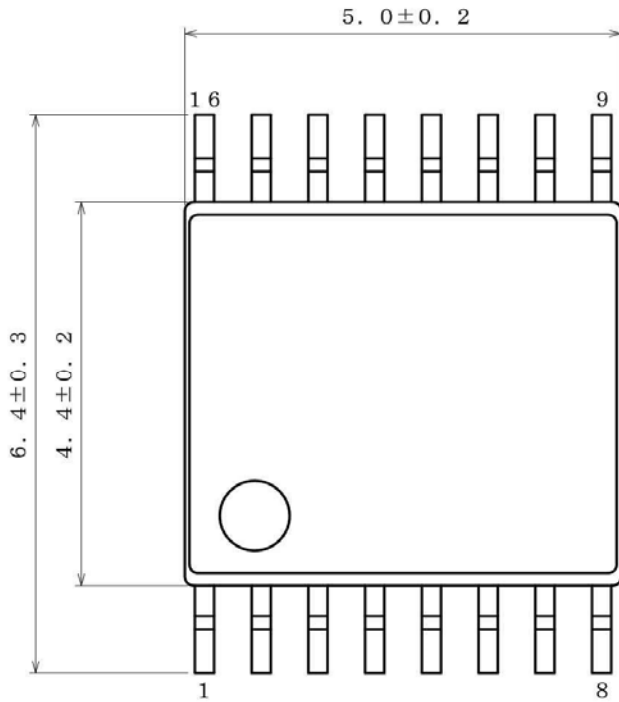

(UNIT : mm)  
 PKG : SSOP-B16  
 Drawing No. B0771

<Tape and Reel information>

Tape	Embossed carrier tape
Quantity	2500pcs
Direction of feed	E2 (The direction is the 1pin of product is at the upper left when you hold reel on the left hand and you pull out the tape on the right hand)

1pin  
 \*Order quantity needs to be multiple of the minimum quantity.

Revision History

Date	Revision	Changes
2016.03.29	001	New Release
2016.04.21	002	Page.3 Footprints and Traces 74.2mm <sup>2</sup> (Square) ⇒ 74.2mm x 74.2mm  Page.12 Table of Operations Operation Mode : TSD PBUS Terminal : High(4.5V(Typ)) to Hi-z

# Notice

## Precaution on using ROHM Products

1. If you intend to use our Products in devices requiring extremely high reliability (such as medical equipment <sup>(Note 1)</sup>, aircraft/spacecraft, nuclear power controllers, etc.) and whose malfunction or failure may cause loss of human life, bodily injury or serious damage to property ("Specific Applications"), please consult with the ROHM sales representative in advance. Unless otherwise agreed in writing by ROHM in advance, ROHM shall not be in any way responsible or liable for any damages, expenses or losses incurred by you or third parties arising from the use of any ROHM's Products for Specific Applications.

(Note1) Medical Equipment Classification of the Specific Applications

JAPAN	USA	EU	CHINA
CLASS III	CLASS III	CLASS II b	CLASS III
CLASS IV		CLASS III	

2. ROHM designs and manufactures its Products subject to strict quality control system. However, semiconductor products can fail or malfunction at a certain rate. Please be sure to implement, at your own responsibilities, adequate safety measures including but not limited to fail-safe design against the physical injury, damage to any property, which a failure or malfunction of our Products may cause. The following are examples of safety measures:
  - [a] Installation of protection circuits or other protective devices to improve system safety
  - [b] Installation of redundant circuits to reduce the impact of single or multiple circuit failure
3. Our Products are not designed under any special or extraordinary environments or conditions, as exemplified below. Accordingly, ROHM shall not be in any way responsible or liable for any damages, expenses or losses arising from the use of any ROHM's Products under any special or extraordinary environments or conditions. If you intend to use our Products under any special or extraordinary environments or conditions (as exemplified below), your independent verification and confirmation of product performance, reliability, etc. prior to use, must be necessary:
  - [a] Use of our Products in any types of liquid, including water, oils, chemicals, and organic solvents
  - [b] Use of our Products outdoors or in places where the Products are exposed to direct sunlight or dust
  - [c] Use of our Products in places where the Products are exposed to sea wind or corrosive gases, including Cl<sub>2</sub>, H<sub>2</sub>S, NH<sub>3</sub>, SO<sub>2</sub>, and NO<sub>2</sub>
  - [d] Use of our Products in places where the Products are exposed to static electricity or electromagnetic waves
  - [e] Use of our Products in proximity to heat-producing components, plastic cords, or other flammable items
  - [f] Sealing or coating our Products with resin or other coating materials
  - [g] Use of our Products without cleaning residue of flux (even if you use no-clean type fluxes, cleaning residue of flux is recommended); or Washing our Products by using water or water-soluble cleaning agents for cleaning residue after soldering
  - [h] Use of the Products in places subject to dew condensation
4. The Products are not subject to radiation-proof design.
5. Please verify and confirm characteristics of the final or mounted products in using the Products.
6. In particular, if a transient load (a large amount of load applied in a short period of time, such as pulse. is applied, confirmation of performance characteristics after on-board mounting is strongly recommended. Avoid applying power exceeding normal rated power; exceeding the power rating under steady-state loading condition may negatively affect product performance and reliability.
7. De-rate Power Dissipation depending on ambient temperature. When used in sealed area, confirm that it is the use in the range that does not exceed the maximum junction temperature.
8. Confirm that operation temperature is within the specified range described in the product specification.
9. ROHM shall not be in any way responsible or liable for failure induced under deviant condition from what is defined in this document.

## Precaution for Mounting / Circuit board design

1. When a highly active halogenous (chlorine, bromine, etc.) flux is used, the residue of flux may negatively affect product performance and reliability.
2. In principle, the reflow soldering method must be used on a surface-mount products, the flow soldering method must be used on a through hole mount products. If the flow soldering method is preferred on a surface-mount products, please consult with the ROHM representative in advance.

For details, please refer to ROHM Mounting specification

### Precautions Regarding Application Examples and External Circuits

1. If change is made to the constant of an external circuit, please allow a sufficient margin considering variations of the characteristics of the Products and external components, including transient characteristics, as well as static characteristics.
2. You agree that application notes, reference designs, and associated data and information contained in this document are presented only as guidance for Products use. Therefore, in case you use such information, you are solely responsible for it and you must exercise your own independent verification and judgment in the use of such information contained in this document. ROHM shall not be in any way responsible or liable for any damages, expenses or losses incurred by you or third parties arising from the use of such information.

### Precaution for Electrostatic

This Product is electrostatic sensitive product, which may be damaged due to electrostatic discharge. Please take proper caution in your manufacturing process and storage so that voltage exceeding the Products maximum rating will not be applied to Products. Please take special care under dry condition (e.g. Grounding of human body / equipment / solder iron, isolation from charged objects, setting of Ionizer, friction prevention and temperature / humidity control).

### Precaution for Storage / Transportation

1. Product performance and soldered connections may deteriorate if the Products are stored in the places where:
  - [a] the Products are exposed to sea winds or corrosive gases, including Cl<sub>2</sub>, H<sub>2</sub>S, NH<sub>3</sub>, SO<sub>2</sub>, and NO<sub>2</sub>
  - [b] the temperature or humidity exceeds those recommended by ROHM
  - [c] the Products are exposed to direct sunshine or condensation
  - [d] the Products are exposed to high Electrostatic
2. Even under ROHM recommended storage condition, solderability of products out of recommended storage time period may be degraded. It is strongly recommended to confirm solderability before using Products of which storage time is exceeding the recommended storage time period.
3. Store / transport cartons in the correct direction, which is indicated on a carton with a symbol. Otherwise bent leads may occur due to excessive stress applied when dropping of a carton.
4. Use Products within the specified time after opening a humidity barrier bag. Baking is required before using Products of which storage time is exceeding the recommended storage time period.

### Precaution for Product Label

A two-dimensional barcode printed on ROHM Products label is for ROHM's internal use only.

### Precaution for Disposition

When disposing Products please dispose them properly using an authorized industry waste company.

### Precaution for Foreign Exchange and Foreign Trade act

Since concerned goods might be fallen under listed items of export control prescribed by Foreign exchange and Foreign trade act, please consult with ROHM in case of export.

### Precaution Regarding Intellectual Property Rights

1. All information and data including but not limited to application example contained in this document is for reference only. ROHM does not warrant that foregoing information or data will not infringe any intellectual property rights or any other rights of any third party regarding such information or data.
2. ROHM shall not have any obligations where the claims, actions or demands arising from the combination of the Products with other articles such as components, circuits, systems or external equipment (including software).
3. No license, expressly or implied, is granted hereby under any intellectual property rights or other rights of ROHM or any third parties with respect to the Products or the information contained in this document. Provided, however, that ROHM will not assert its intellectual property rights or other rights against you or your customers to the extent necessary to manufacture or sell products containing the Products, subject to the terms and conditions herein.

### Other Precaution

1. This document may not be reprinted or reproduced, in whole or in part, without prior written consent of ROHM.
2. The Products may not be disassembled, converted, modified, reproduced or otherwise changed without prior written consent of ROHM.
3. In no event shall you use in any way whatsoever the Products and the related technical information contained in the Products or this document for any military purposes, including but not limited to, the development of mass-destruction weapons.
4. The proper names of companies or products described in this document are trademarks or registered trademarks of ROHM, its affiliated companies or third parties.

**General Precaution**

1. Before you use our Products, you are requested to carefully read this document and fully understand its contents. ROHM shall not be in any way responsible or liable for failure, malfunction or accident arising from the use of any ROHM's Products against warning, caution or note contained in this document.
2. All information contained in this document is current as of the issuing date and subject to change without any prior notice. Before purchasing or using ROHM's Products, please confirm the latest information with a ROHM sales representative.
3. The information contained in this document is provided on an "as is" basis and ROHM does not warrant that all information contained in this document is accurate and/or error-free. ROHM shall not be in any way responsible or liable for any damages, expenses or losses incurred by you or third parties resulting from inaccuracy or errors of or concerning such information.