

NUMBER C-160018-E

DRAWING MADE IN AMERICAN PROJECTION

LTR	REVISION RECORD	DWN	CHK	DATE
C1	ECO-09-026346	KK	AEG	27NOV09

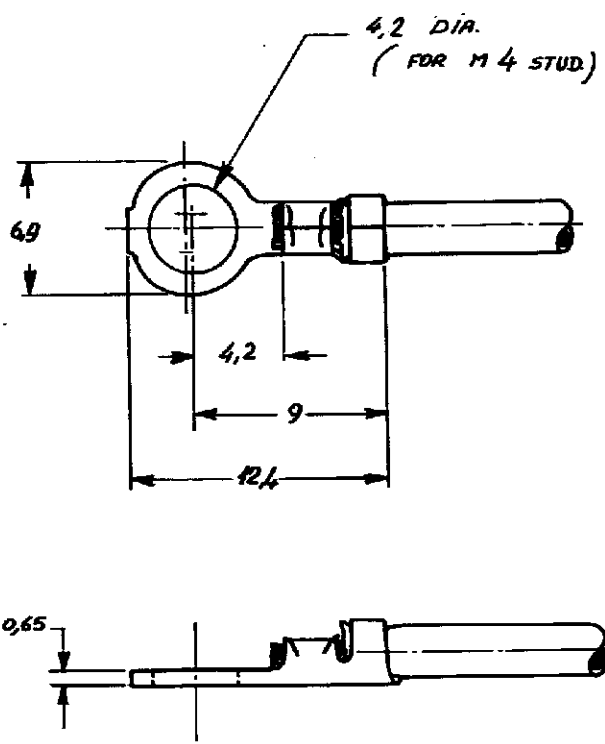

NOTES:
 1. FOR USE ON STANDARD APPLICATOR AND MULTIPLE APPLICATOR.
 2. FOR USE ON MULTIPLE APPLICATOR, AMP D. METER APPLICATOR.
 3. OBSOLETE PARTS: OBSOLETE CIS STREAMLINING PER D.RENAUD/D.SINISI

DIMENSIONS IN M.M. DO NOT SCALE PRINT

160018-1	STEEL	NICKEL PL.	1
160018-3	BRASS	NICKEL PL.	1
160018-8	PHOS. BRONZE	TIN PLATED	1
160018-7	PHOS. BRONZE	UNPLATED	1
160018-6	BRASS	TIN PLATED	1
160018-5	BRASS	UNPLATED	1
160018-4	PHOS. BRONZE	TIN PLATED	1
160018-3	PHOS. BRONZE	UNPLATED	1
160018-2	BRASS	TIN PLATED	1
160018-1	BRASS	UNPLATED	1

OBSOLETE 3

DOC. CENTRE
14 JUNI 1993

CUSTOMER COPY FOR REFERENCE ONLY

©1968 BY AMP-HOLLAND N.V. ALL RIGHTS RESERVED A-MP PRODUCTS COVERED BY PATENTS AND/OR PATENTS PENDING.



WIRE RANGE	INSUL. RANGE	FIRST USED
0.50-1.63 mm ²	18-23 DIA.	11

ORDER NO.	MATERIAL	PLATING	SCALE	LOC	SIZE	NO	REV
160018-E			4:1	H	A	C-160018-E	C1
DESIGNER	DATE	DATE	NAME				
A. Conplam	22/7/68	1/2/68	RINGTONGUE FOR M4 STUD				
CHK	DATE	APP					