

PART NUMBER	REV	TERMINATOR	FEED TYPE	DESCRIPTION
1529275-1	A	BENCH & LEADMAKER	MECH POST FEED	HDI APPLICATOR
7-1529275-1	A	BENCH & LEADMAKER	MECH POST FEED	-1 AND SPARE PARTS
7-1529275-7	A	-	-	SPARE PARTS KIT

LOC	DIST	REV	DATE	DWN	APVD
A	66	A	27AUG2008	RK	GB

CRIMP DATA INARCA TERMINAL TE CRIMP SPECS

CRIMP	SIZE	TYPE	RANGE
WIRE	2.79 [ .110 IN ]	F	1.00-2.50mm <sup>2</sup>
INSUL	4.57 [ .180 IN ]	F	2.40-4.00 [ .094-.157 IN ]

WIRE STRIP LENGTH 4.96-5.76 [ .195-.227 IN ]

APPL INSTRUCTIONS 408-8323 & 408-8490

TERMINAL APPL SPEC - FEED 30.00 [ 1.181 IN ]

TERMINALS APPLIED

TE TERM PN	MANUF TERM PN		
1949754-1	0010689001	-	-
1949754-2	0010689201	-	-
1949754-3	0110689001	-	-
1949754-4	0110689201	-	-

WIRE SIZE	CRIMP HEIGHT	REF SETTING
2.50mm <sup>2</sup>	2.03 ± 0.05 [ .080 ± .002 IN ]	B1
2.00mm <sup>2</sup>	1.91 ± 0.05 [ .075 ± .002 IN ]	C1
1.50mm <sup>2</sup>	1.75 ± 0.05 [ .069 ± .002 IN ]	D0
1.00mm <sup>2</sup>	1.60 ± 0.05 [ .063 ± .002 IN ]	E6

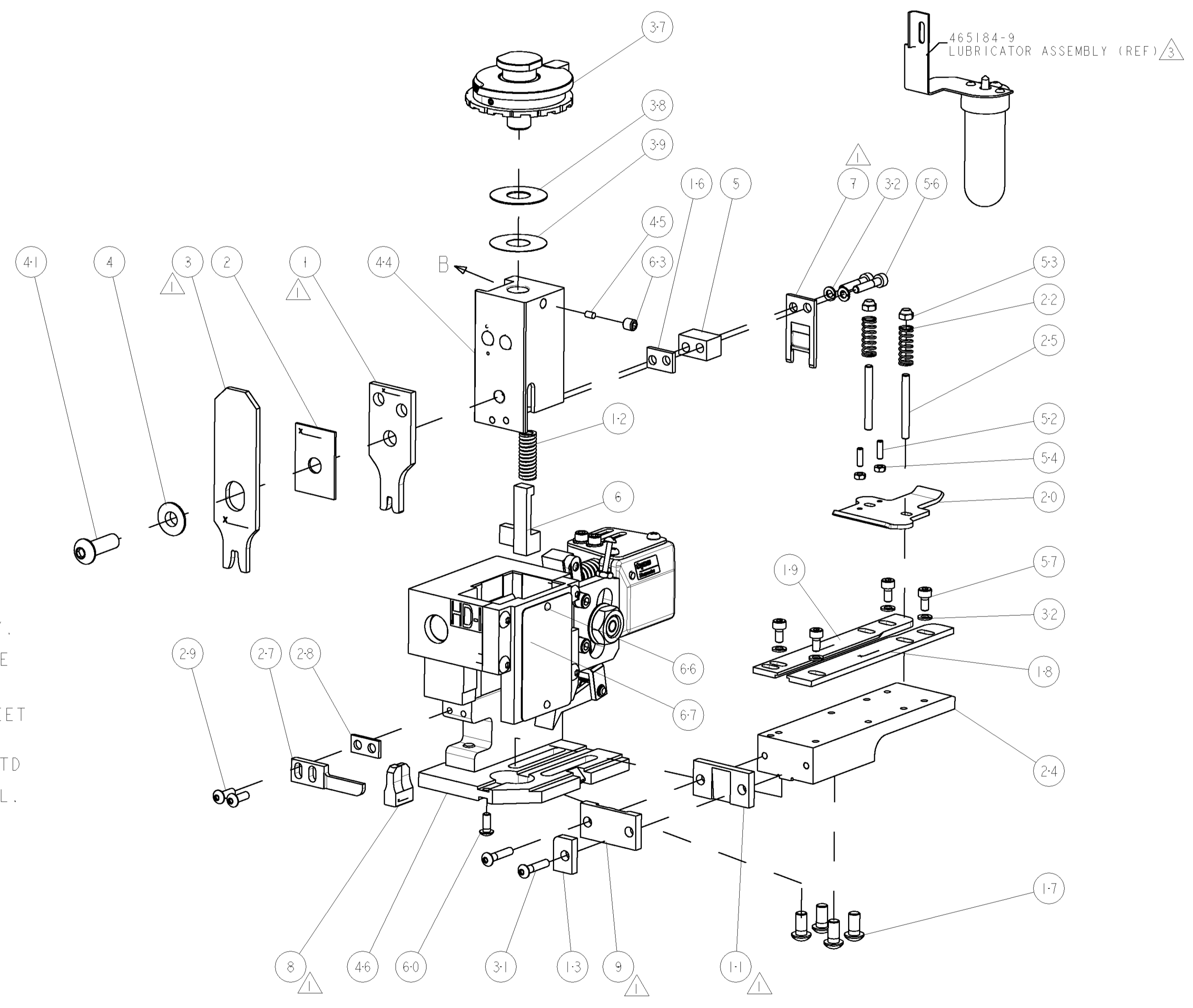

- 1 RECOMMENDED SPARE PARTS
- 2 GREASE RAM, CAM, CAM FOLLOWER AND FEED ROD LIGHTLY.
- 3 CERTAIN TERMINALS REQUIRE LUBRICATION. REFER TO THE APPLICATOR INSTRUCTION SHEET FOR MORE INFORMATION.
- 4 LUBRICATE DAILY PER THE APPLICATOR INSTRUCTION SHEET SUPPLIED WITH THE APPLICATOR.
- 5 ALL CRIMP DATA CALCULATED BY TYCO ELECTRONICS UK LTD
- 6 WIRE AND INSULATION RANGES ARE THAT OF THE TERMINAL.

**\* WARNING**  
 ON INSTALLATION, SET WIRE DISC TO LARGEST WIRE SIZE SETTING. USE OF SETTINGS BELOW MIN. REQUIRED CRIMP HEIGHT SETTING WILL CAUSE DAMAGE TO CRIMP TOOLING.

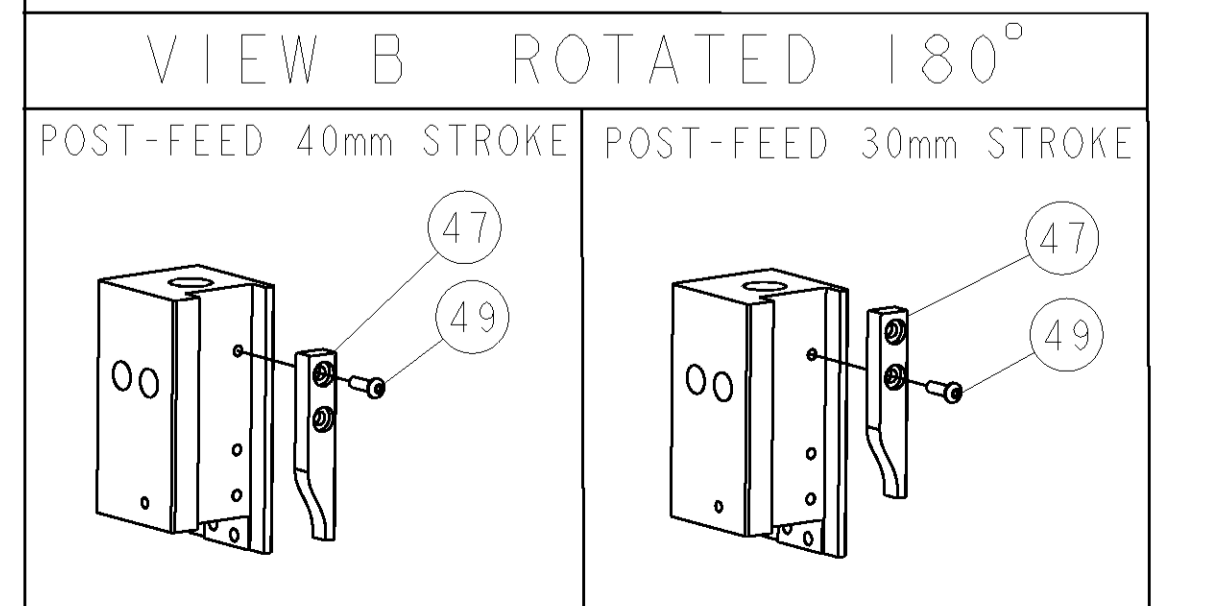

-	1	1	1338705-4	DOCUMENTATION PACKAGE	71	
-	1	1	461264-5	PLATE, IDENTIFICATION	67	
-	2	2	21017-2	SCREW, DRIVE	66	
-	1	1	3-18031-0	SCR, SET, CUP POINT M6 X 6.0	63	
-	1	1	18024-7	SCR, BTN SKT HD CAP (M4 X 10.0)	60	
-	4	4	1-18023-0	SCR, SKT HD CAP M4 X 8.0	57	
-	2	2	1-18023-4	SCR, SKT HD CAP M4 X 20.0	56	
-	2	2	18029-1	NUT, HEX, REG M3	54	
-	2	2	986965-1	NUT, LOCK, HEX, TORQUE (M4)	53	
-	2	2	2-18032-2	SCR, SET, FLT POINT M3 X 10.0	52	
-	1	1	18024-3	SCR, BTN SKT HD CAP (M3 X 10.0)	49	
-	1	1	1338676-1	CAM, UNIVERSAL POST-FEED	47	
-	1	1	1338662-1	SUB ASSY, APPLICATOR FRAME	46	
-	1	1	690191-1	PLUG, NYLON	45	
-	1	1	1333260-1	RAM	44	
-	1	1	2-18024-6	SCR, BTN SKT HD CAP (M8 X 25.0)	41	
-	1	1	690125-1	SHIM SUB-ASSY	39	
-	1	1	1-469367-2	SHIM	38	
-	1	1	879103-2	FINE ADJUST HEAD ASSEMBLY	37	
-	6	6	18025-2	WASHER, SPRG LOCK, REG M4	32	
-	2	2	1-18024-0	SCR, BTN SKT HD CAP (M4 X 20.0)	31	
-	2	2	18024-8	SCR, BTN SKT HD CAP (M4 X 12.0)	29	
-	1	1	3-690451-2	SPACER, STRIPPER	28	
-	1	1	240639-1	STRIPPER (MACHINING)	27	
-	2	2	1320906-1	STUD, THREADED	25	
-	1	1	1320995-5	PLATE, STRIP GUIDE	24	
-	2	2	2-22281-6	SPRING, COMPRESSION	22	
-	1	1	1338665-1	DRAG	20	
-	1	1	458030-4	STRIP GUIDE, REAR	19	
-	1	1	458031-4	STRIP GUIDE, FRONT	18	
-	4	4	1-18024-8	SCR, BTN SKT HD CAP (M6 X 12.0)	17	
-	1	1	1338708-1	SPACER, SLUG BLADE	16	
-	1	1	2-690481-0	SPACER, HOLD DOWN	13	
-	1	1	23846-1	SPRING, DIE	12	
-	1	1	240644-9	PLATE, REAR SHEAR	11	
-	-	-	-	-	10	
-	1	1	5-690482-9	PLATE, FRONT SHEAR	9	
-	1	2	1633387-2	ANVIL, COMBINATION	8	
-	1	1	690474-3	BLADE, SLUG	7	
-	1	1	8-455892-6	HOLD DOWN, TERMINAL	6	
-	1	1	2-240641-6	SPACER	5	
-	1	1	238009-1	BLOCK, FL CRIMPER SPACER	4	
-	1	2	1	3-1424909-0	CRIMPER, INSULATION F	3
-	1	1	1-455888-0	SPACER, CRIMPER	2	
-	1	2	1	3-456408-3	CRIMPER, WIRE PREMIUM	1
-	77	-71	-1	PART NO	DESCRIPTION	ITEM NO

TYCO ELECTRONICS CORPORATION, 1000 W. CLIFFORD AVE., HARRISBURG, PA 17105-3608

DATE: 05AUG2008  
 CHK: J. LOFTHOUSE  
 T. ELBIN  
 APVD: M. CLIFFORD

NAME: FINE ADJUST END FEED HDI APPLICATOR

SIZE: A1  
 CAGE CODE: 00779  
 DRAWING NO: C=1529275

SCALE: 3:5 SHEET 1 OF 1 REV A