

4

3

2

1

THIS DRAWING IS UNPUBLISHED. RELEASED FOR PUBLICATION .19 .  
 © COPYRIGHT 19 BY AMP INCORPORATED. ALL RIGHTS RESERVED.

LOC	DIST	REVISIONS					
		P	LTR	DESCRIPTION	DATE	DWN	APVD
G	14		M	REL PER 0G3A-0762-00	21NOV00	JR	MS

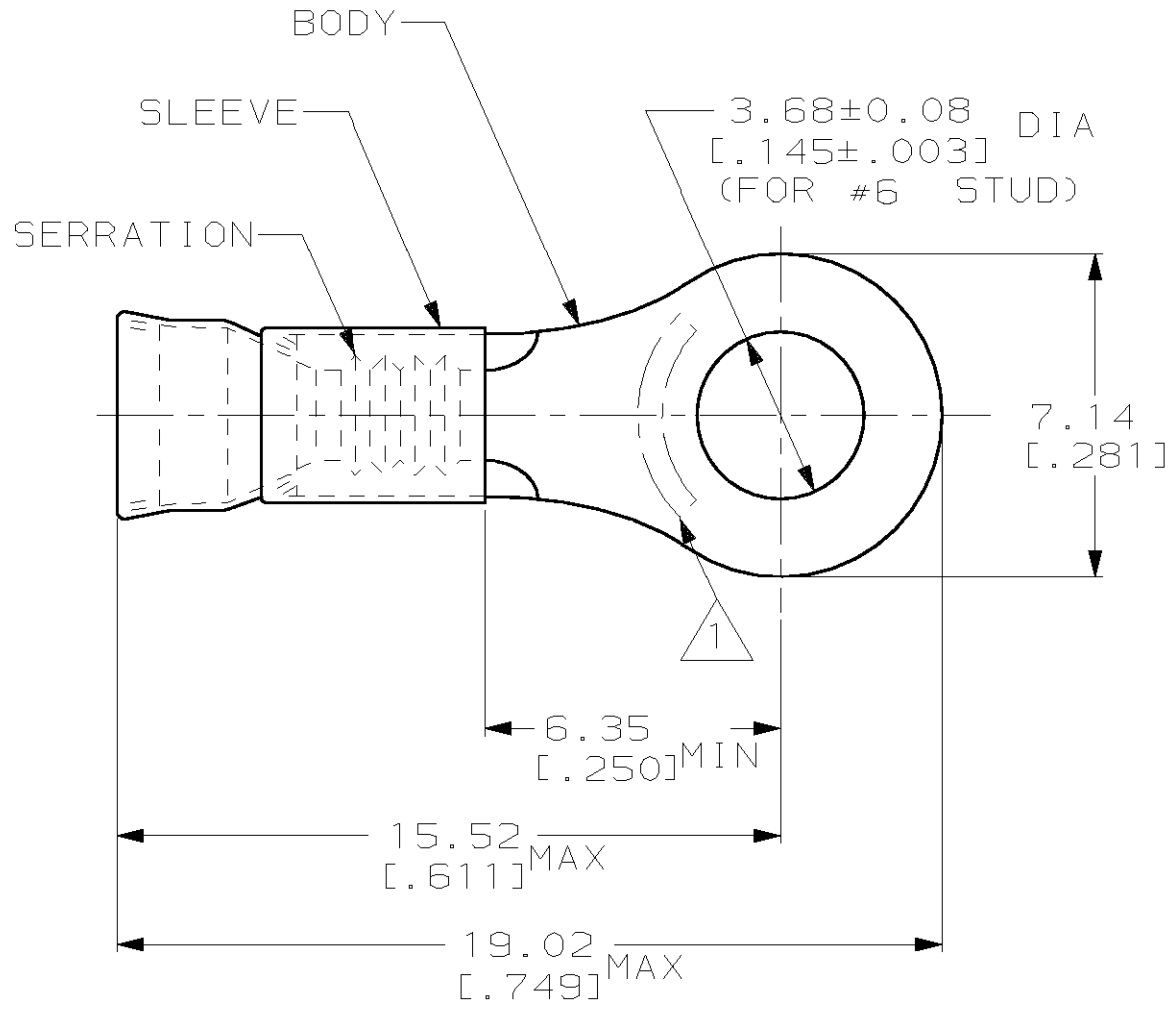

- 1 STAMP AMP 22-18\*APPROX AS SHOWN  
22-16 TERMINALS ARE STAMPED 22-18 IN ACCORDANCE WITH MILITARY SPEC MIL-T-7928 COMMERCIAL WIRE RANGE IS 22-16
- 2. WIRE INSUL DIA, 2.67-3.56 [.105-.140]
- 3. TONGUE MATL THK, 0.79±0.05 [.031±.002]
- 4 BODY, NICKEL-PLATE PER QQ-N-290.
- 5 BODY, GOLD-PLATE WITH NICKEL UNDERPLATE PER ASTM B-488.

4	5000	ON TAPE, REEL	2-323199-1
5	1000	LOOSE PIECE	323199-1
4	1000	LOOSE PIECE	323199
FINISH	QTY	PACKAGE TYPE	PART NO

AMP INCORPORATED  
 CUSTOMER SERVICE SYSTEM

FOR ADDITIONAL PRODUCT INFORMATION OR COPIES OF DRAWINGS AND TECHNICAL DOCUMENTS  
 PRODUCT INFORMATION CENTER  
 1-800-522-6752

FOR APPLICATION TOOLING INFORMATION  
 TOOLING ASSISTANCE CENTER  
 1-800-722-1111

FOR ORDER ENTRY  
 1-800-526-5142

MAX RECOMMENDED OPERATING TEMPERATURE:  
 343°C [650°F]

VOLTAGE RATING:  
 -

CIRCULAR MIL AREA:  
 0.26mm<sup>2</sup>-1.65mm<sup>2</sup> [509-3260]

STRANDED WIRE

THIS DRAWING IS A CONTROLLED DOCUMENT FOR AMP INCORPORATED. IT IS SUBJECT TO CHANGE AND THE CONTROLLING ENGINEERING ORGANIZATION SHOULD BE CONTACTED FOR THE LATEST REVISION.

DIMENSIONS:  
 mm [in]

TOLERANCES UNLESS OTHERWISE SPECIFIED:

0 PLC	±-
1 PLC	±-
2 PLC	±0.20 [.008]
3 PLC	±-
4 PLC	±-
ANGLES	±-

FINISH  
 SEE TABLE

MATERIAL  
 BODY, CU PER ASTM B152  
 SLEEVE, NI SIL PER ASTM B122

DWN	L OLMEDA	100CT94	<b>AMP</b> AMP Incorporated Harrisburg, PA 17105-3608
CHK	M ELLIS	100CT94	
APVD	S BORTNER	100CT94	
NAME			TERMINAL, RING TONGUE, STRATOTHERM, DIAMOND GRIP, WIRE SIZE, 22-16 AWG
SIZE			A3
CAGE CODE			00779
DRAWING NO			C-323199
SCALE			6:1
SHEET			1 OF 1
REV			M

CUSTOMER DRAWING