

THIS DRAWING IS UNPUBLISHED. RELEASED FOR PUBLICATION, 19 .
 © COPYRIGHT 19 BY AMP INCORPORATED. ALL INTERNATIONAL RIGHTS RESERVED.

LOC	DIST	P	F	ZONE	LTR	DESCRIPTION	DATE	APPD
G	14					REV PER 063A-0123-02	07MAR02	JR MS

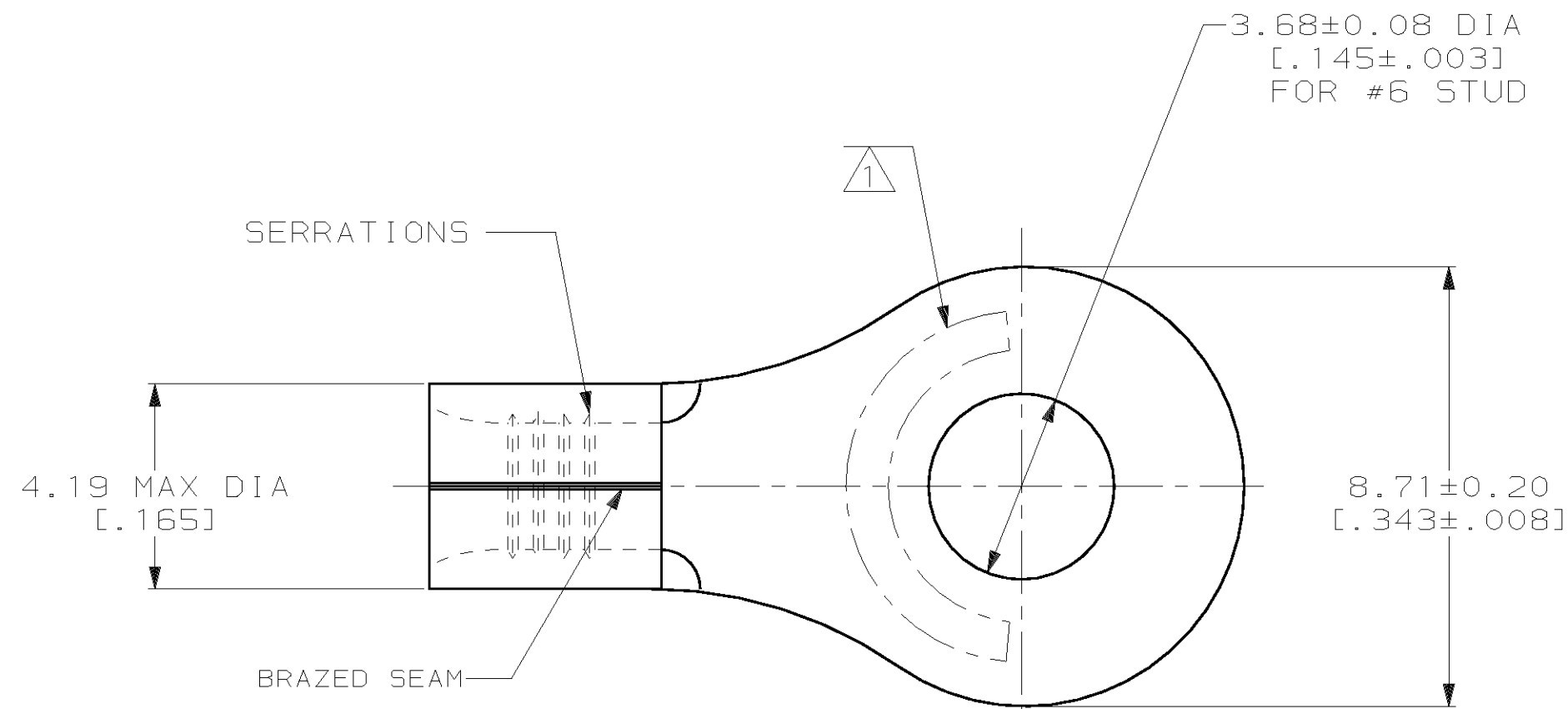

AMP WIRE RANGE	UL E13288 Listed
16-14 AWG SOLID OR STRANDED	16-14 AWG SOLID OR STRANDED
SP LR7189 Certified	MILITARY P/N AND CLASS
16-14 AWG SOLID OR STRANDED	NOT APPLICABLE

- ① STAMP AMP 16-14* APPROX AS SHOWN
- ② 0.00254 [.000100] MIN TIN PER ASTM B-545.
- ③ CLEANED, UNPLATED

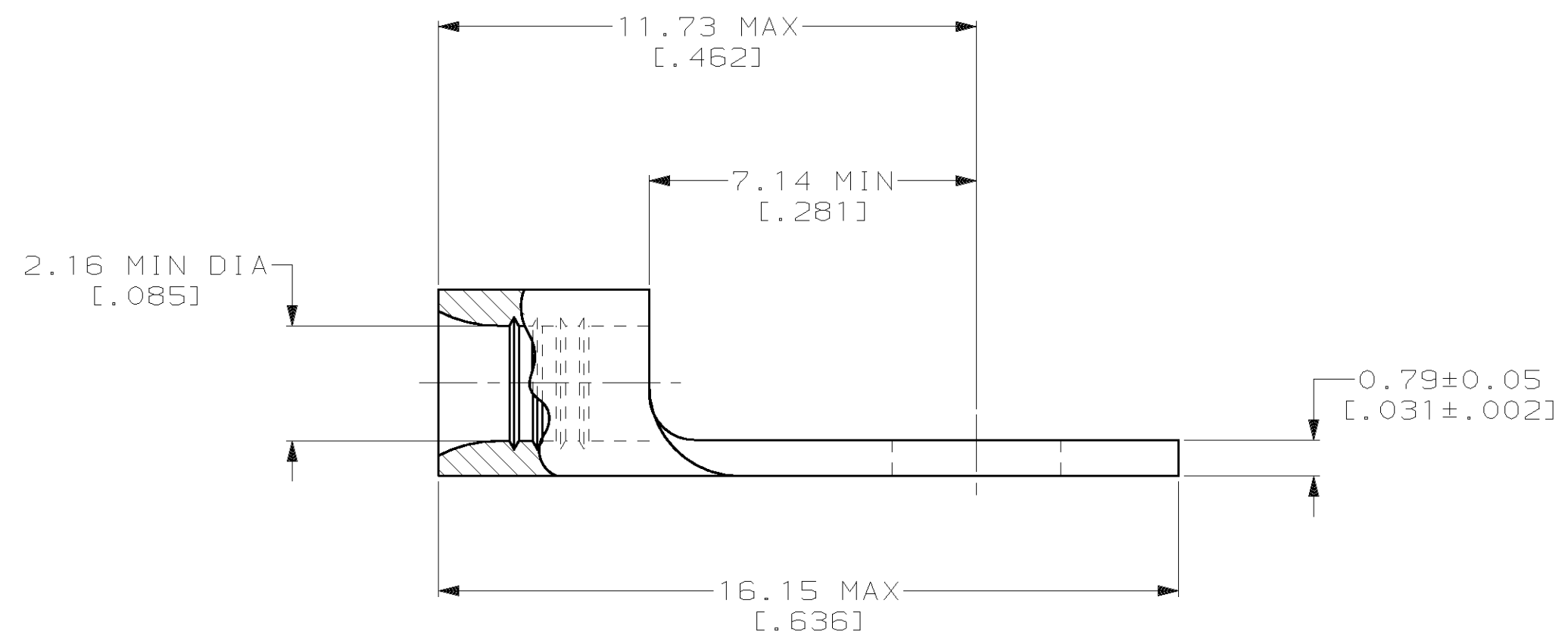

FINISH	QUANTITY	PACKAGING TYPE	PART NO
③ -		LOOSE PIECE	34121-1
②	100	LOOSE PIECE, BOX	8-34121-1
	5000	ON TAPE	2-34121-1
	---	LOOSE PIECE	34121

AMP INCORPORATED CUSTOMER SERVICE SYSTEMS		MAX RECOMMENDED OPERATING TEMPERATURE: 170°C MAX	DO NOT SCALE PRINT. UNLESS SPECIFIED DIMENSIONS IN mm [INCHES] TOLERANCES ON: 2 PLC DEC ± - 3 PLC DEC ± - ANGLES ± -	DR 3-11-93 TA BRINKMAN CHK 3-11-93 DA PATTERSON APPD 3-11-93 DE MILLER APPD 3-11-93 JL MECKLEY	AMP AMP Incorporated Harrisburg, PA 17105-3608	
FOR ADDITIONAL PRODUCT INFORMATION OR COPIES OF DRAWINGS AND TECHNICAL DOCUMENTS	PRODUCT INFORMATION CENTER 1-800-522-6752	VOLTAGE RATING: NOT APPLICABLE	MATERIAL COPPER PER ASTM B-152 ANNEALED	PRODUCT SPEC -	NAME TERMINAL, RING TONGUE, SOLISTRAND	
FOR APPLICATION TOOLING INFORMATION	TOOLING ASSISTANCE CENTER 1-800-722-1111	WIRE CROSS SECTIONAL AREA RANGE: 1.04-2.62mm ² [2,050-5,180] CIR MILS SOLID OR STRANDED	FINISH - SEE TABLE -	APPLICATION SPEC -	SIZE C	CAGE CODE 00779
FOR ORDER ENTRY	1-800-526-5142	THIS DRAWING IS A CONTROLLED DOCUMENT FOR AMP INCORPORATED. IT IS SUBJECT TO CHANGE AND THE CONTROLLING ENGINEERING ORGANIZATION SHOULD BE CONTACTED FOR THE LATEST REVISION.		WEIGHT -	DRAWING NO C=34121	SCALE 8:1
					SHEET 1 OF 1	