

Capacitive Sensor Control IC Series

Capacitive Sensor Switch Control IC

BU21009MUV

No.09048EBT03

●Description

BU21009MUV is the capacitive sensor controller for the switch function and slider function with 16 channels sensors. All channels are calibrated for the slider functions. So this is useful for 16 switches application, too. LED driver is available (No PWM function).

●Features

- 1) Slider function
- 2) LED driver available
- 3) 2 wire serial interface
- 4) Power supply = 2.5V to 3.3V, I/O power supply = 1.7V to 3.3V
- 5) Integrated 10bit AD converter, clock and reset
- 6) Package VQFN032V5050

●Applications

It is possible to use it widely as a switch/slider such as a Mobile phone, Portable equipment, and Audiovisual apparatuses.

●Absolute Maximum Ratings (Ta=25°C)

PARAMETER	SYMBOL	RATING		UNIT
		MIN	MAX	
APPLIED VOLTAGE	AVDD	-0.3	4.5	V
	DVDD	-0.3	4.5	
INPUT VOLTAGE	VAIN	-0.3	AVDD+0.3	V
	VDIN	-0.3	DVDD+0.3	
STORAGE TEMPERATURE RANGE	T _{stg}	-55	125	°C
POWER DISSIPATION	P _d	304		mW

Ambient temperature reduces a permission loss by 3.1mW per case more than 25 degrees Celsius, 1 degree Celsius.

●Recommended Operating conditions

PARAMETER	SYMBOL	RATING			UNIT
		MIN	TYP	MAX	
APPLIED VOLTAGE	AVDD	2.5	3.0	3.3	V
	DVDD	1.7	3.0	3.3	V
OPERATING TEMPERATURE RANGE	T _{opr}	-40	25	85	°C

●Electrical characteristics(Especially, Topr=25 °C and AVDD=DVDD=0 as long as it doesn't specify it.)

PARAMETER	SYMBOL	RATING			UNIT	Condition	
		MIN	TYP	MAX			
H INPUT VOLTAGE	V _{IHI0}	DVDDx0.8	-	DVDD+0.3	V		
L INPUT VOLTAGE	V _{ILIO}	DVSS-0.3	-	DVDDx0.2	V		
Output "H" voltage	V _{OHI0}	DVDD-0.7	-	DVDD	V	I _{OH} =-2[mA]. Overshoot is excluded.	
Output "L" voltage	V _{OLLED}	AVSS	-	0.5	V	I _{OL} =8[mA]. Undershoot is excluded. LED output. I _{OL} =3[mA]. Undershoot is excluded. SDA/TXD application. I _{OL} =2[mA]. Undershoot is excluded. INT application.	
	V _{OLTxD}	DVSS	-	0.5			DVDD > 2[V] DVDD ≤ 2[V]
				DVDDx0.3			
V _{OLINT}	DVSS	-	0.5				
Input leakage current	I _{Iz}	-1	-	1	μA		
Off leakage current	I _{oZ}	-1	-	1	μA		
Standby current	I _{ST}	-	-	2	μA	Shutdown (SDN="L")	
Current of operation	I _{DD}	-	300	-	μA		

●A/D Converter

PARAMETER	SYMBOL	RATING			UNIT	Condition
		MIN	TYP	MAX		
Resolution		-	10	-	bit	
Analog Input voltage	V _{AIN}	AVSS	-	AVDD	V	
change clock frequency	f _{adck}	0.2	-	2.0	MHz	
change time	t _{im}	-	77	-	μsec	f _{adck} = 1[MHz]
Zero scale voltage		-	-	AVSS+0.07	V	
full scale voltage		AVDD-0.07	-	-	V	
differential Non line accurate	DNL	-	-	±3	LSB	
Integrate Non line accurate	INL	-	-	±3	LSB	

●CR Oscillator characteristic

PARAMETER	SYMBOL	RATING			UNIT	Condition
		MIN	TYP	MAX		
Frequency Oscillation	f _{cr}	0.4	1.1	2.0	MHz	

●Block Diagram, Pin configuration

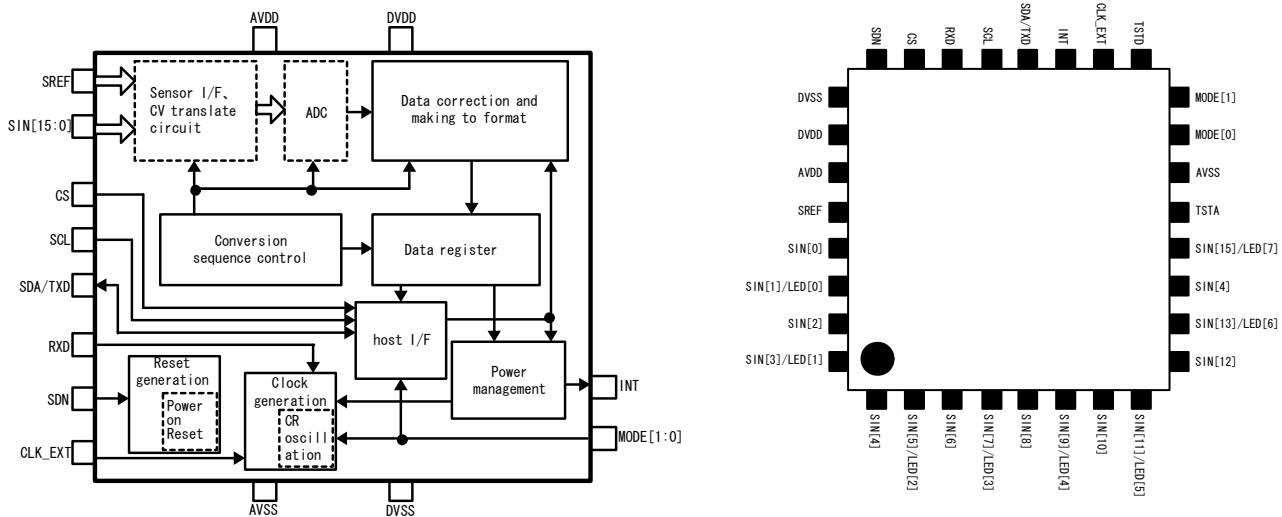

- **Sensor I/F CV translate circuit**
This module selects between sensor inputs. The selection sequences between all 16 channels.
- **AD Conversion**
The voltage into which CV is converted is converted into a digital value. Conversion is 10 bit and full scale corresponds to AVDD.
- **Conversion sequence control**
Performs timing generation for the analogue circuitry and a sequencer circuit for selection of the sensor channel for conversion.
- **Data correction and making to format**
This module provides the digital intelligence of the sensor. The block includes, amongst other things, scaling, adding offsets and input filtering for de-bouncing. Registers are formatted to simplify usage by the software application. The block implements auto-calibration to manage drift in temperature, process variation, voltage variation and aging effects.
- **Data register**
This stores the results for the software application. Please refer to the register map for details.
- **HOST I/F**
2 wire serial interface.
- **Power management**
The power management block provides smart power control. When the sensors are not in use, the Controller automatically transitions into a low-power mode. When a sensor is touched, then the device automatically wakes up and enters its normal operation. The chip drives an INT pin for alerting the controller device in this case.
- **Reset generation**
The circuit is initialized by a either a soft reset command or by the external SDN pin.
- **Clock generation**
The device has an internal oscillator. Provision is also made if the application would like to make use of an external clock input.

● Pin Description

Pin No.	Name	I/O	Function	Note	Supply Reference	Reset Level	I/O Pad
1	SIN4	AIn	sensor input4	-	AVDD	"Hi-Z"	④
2	SIN5/LED2	AIn/Out	sensor input 5 /PW Drive LEDcontrol output 2	sensor input , LED drive select	AVDD	"Hi-Z"	④
3	SIN6	AIn	sensor input6	-	AVDD	"Hi-Z"	④
4	SIN7/LED3	AIn/Out	sensor input 7 /PWM Drive LED control output 3	sensor input , LED drive select	AVDD	"Hi-Z"	④
5	SIN8	AIn	sensor input8	-	AVDD	"Hi-Z"	④
6	SIN9/LED4	AIn/Out	sensor input 9 /LED control output 4	sensor input , LED drive select	AVDD	"Hi-Z"	④
7	SIN10	AIn	sensor input10	-	AVDD	"Hi-Z"	④
8	SIN11/LED5	AIn/Out	sensor input 11 /LED control output 5	sensor input , LED drive select	AVDD	"Hi-Z"	④
9	SIN12	AIn	sensor input12	-	AVDD	"Hi-Z"	④
10	SIN13/LED 6	AIn/Out	sensor input 13 /LED control output 6	sensor input , LED drive select	AVDD	"Hi-Z"	④
11	SIN14	AIn	sensor input14	-	AVDD	"Hi-Z"	④
12	SIN15/LED 7	AIn/Out	sensor input 15 /LED control output 7	sensor input , LED drive select	AVDD	"Hi-Z"	④
13	TSTA	AIn	Test input for analog block	NC on the substrate is recommended.	AVDD	"Hi-Z"	④
14	AVSS	Ground	Analog ground	-	-	-	-
15	MODE[0]	In	Mode selection, input0	00 = 2wires serial, internal clock	DVDD	-	①
16	MODE[1]	In	Mode selection, input1		DVDD	-	①
17	TSTD	In	Digital part test input	Usually must be tide to "L"	DVDD	-	①
18	CLK_EXT	In	External system clock input	Usually tide to "L"	DVDD	-	①
19	INT	Out	Output of interrupt	"L" : Active mode "H" : Idle mode ※2	DVDD	"L"	③
20	SDA/TXD	In/Out	Communication data sending and receiving(2wires serial)	-	DVDD	"Hi-Z"	⑤
						-	②
21	SCL	In	Communication synchronous clock input	-	DVDD	-	②
22	RXD	In	system clock input (2wires serial)	"L" : Internal clock "H" : external clock	DVDD	-	②
23	CS	In	Slave address selection (2wires serial mode)	"L" : 5Ah "H" : 5Bh	DVDD	-	②
24	SDN	In	Shutdown input	"L" : Halt condition "H" : state of operation	DVDD	-	-
25	DVSS	Ground	Digital part ground	-	-	-	-
26	DVDD	Power	Digital part Power supply	-	-	-	-
27	AVDD	Power	Analog part Power supply	-	-	-	④
28	SREF	AIn	Standard capacitor input	-	AVDD	"Hi-Z"	④
29	SIN0	AIn	sensor input 0	-	AVDD	"Hi-Z"	④
30	SIN1/LED0	AIn/Out	sensor input 1 /PWM Drive LEDcontrol output 0	sensor input , LED drive select	AVDD	"Hi-Z"	④
31	SIN2	AIn	sensor input 2	-	AVDD	"Hi-Z"	④
32	SIN3/LED1	AIn/Out	sensor input 3 /PWM Drive LEDcontrol output 1	sensor input , LED drive select	AVDD	"Hi-Z"	④

*1 Initial State When internal organs power-on reset is effective
Halt condition SDN="L"

● I/O Circuit

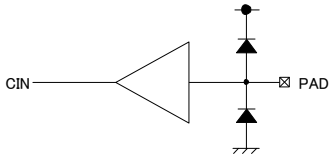
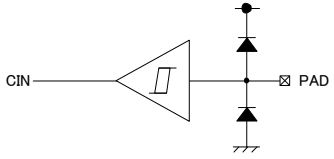
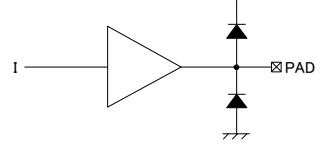
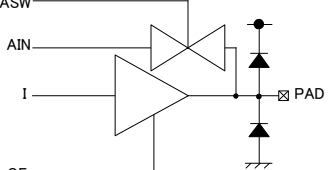
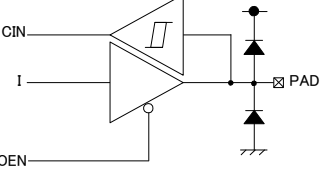
① CMOS INPUT	② CMOS Schmitt INPUT	③ CMOS OUTPUT
		
④ CMOS 3stute OUTPUT with ANALOG-SW	⑤ CMOS Schmitt INOUT	
		

●HOST I/F

- 2 wire serial, BUS (Pin configuration, MODE [1:0] =00b)
 Slave mode only
 Slave Address = 5Ch,5Dh selection possible.
 Normal (Normal mode. 100kHz Transfer rate)
 Fs mode (Fast mode. 400kHz Transfer rate) also.
 Not adapting sequential read / write.

【Data format】

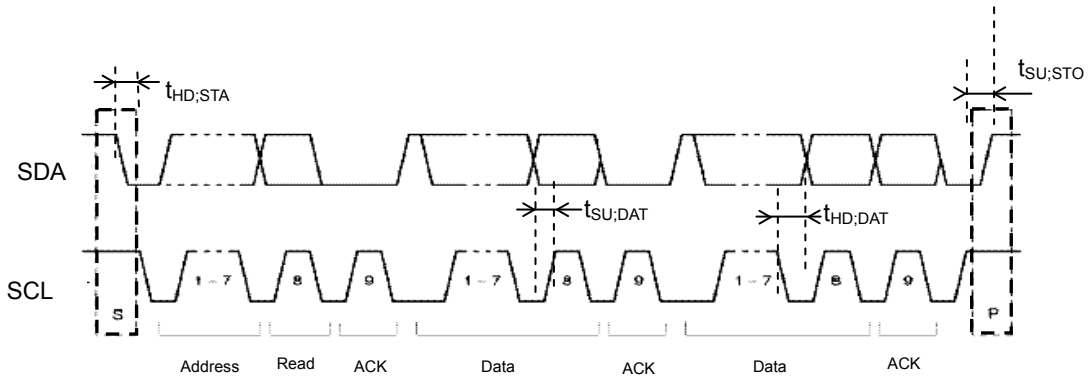

Parameter	Standard mode		High Speed mode		Unit
	MIN	MAX	MIN	MAX	
fSCL : SCL Clock Freq	0	100	0	400	kHz
t _{HD,STA} : START condition hold time	4.0	-	0.6	-	μsec
t _{LOW} : SCL "L"	4.7	-	1.3	-	μsec
t _{HIGH} : SCL "H"	4.0	-	0.6	-	μsec
t _{HD,DAT} : Data hold time	0.1	3.45	0.1	0.9	μsec
t _{SU,DAT} : Data setup time	0.25	-	0.1	-	μsec
t _{SU,STO} : START condition hold time	4.0	-	0.6	-	μsec
t _{BUF} : Free time of bus between STOP condition and START condition	4.7	-	1.3	-	μsec

【PROTOCOL】

- Write Protocol



- Read Protocol

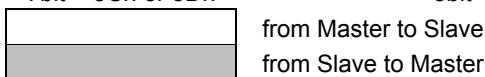
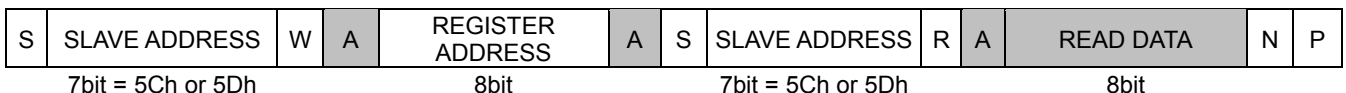

- S = START condition
- P = STOP condition
- R = data direction READ (SDA HIGH)
- W = data direction WRITE (SDA LOW)
- A = acknowledge (SDA LOW)
- N = not acknowledge (SDA HIGH)

●Register map

Address	Register name	R/W	Length	Explanation
1*h	SENS_DATA	R	1byte / channel	Sensor output data. One for each channel.
30h	POSX	R	1byte	X positional value axially.
31h	POSY	R	1byte	Y positional value axially.
32h, 33h	BTN	R	2byte	Button On/Off.
4*h	OFFSET	R	1byte / channel	Offset correction data. One for each channel.
ECh	POS_MODE	W	1byte	XY matrix setting.
EDh	RESET	W	1byte	Soft reset execution.
EEh	CALIB	W	1byte	Soft calibration execution.
EFh	DONE	W	1byte	Setting done command.
F0h, F1h	SENS_CH	W	2byte	Sensor channel enables.
F2h	LED_CH	W	1byte	LED channel enables.
F3h, F4h	IDLE_CH	W	2byte	Idle mode release control.
F5h	LED_LINK	W	1byte	LED linkage to sensor input.
F6h	TIMES	W	1byte	Defines the sampling interval and number of samples required to recognize a button press.
F7h	TH_ON2	W	1byte	A second threshold value in the detection of a button going from OFF state to ON state.
F8h, F9h	TH_ON2_CH	W	2byte	Per channel selection of whether to use TH_ON or TH_ON2.
FAh	CMD	W	1byte	Simultaneous press and idle mode entry.
FBh	GAIN_FILTER	W	1byte	Gain setting, filter function.
FCh	TH_ON	W	1byte	A threshold value in the detection of a button going from OFF state to ON state.
FDh	TH_OFF	W	1byte	A threshold value in the detection of a button going from ON state to OFF state.
FEh	DLED	W	1byte	Register to allow simple writing to LEDs.

[1*h : Sensor Output Data]

Name: SENS_DATA

Address: 1* h (one byte per sensor channel)

Description: The sensor output that converts to 10bit. Scaling, offsets and filtering (when enabled) are applied. The most significant 8 bits are presented to the software with this register.

	Bit7	Bit6	Bit5	Bit4	Bit3	Bit2	Bit1	Bit0
1*h	SD *[7]	SD *[6]	SD *[5]	SD *[4]	SD *[3]	SD *[2]	SD *[1]	SD *[0]
R/W	R	R	R	R	R	R	R	R
Initial val.	1	0	0	0	0	0	0	0

[30h : X positional value axially]

Name: POSX

Address: 30h

Description: This represents the X-position of the press. The value is calculated differently depending on the matrix arrangement. For example when:

- When POS_MODE[0]=0 : Value interprets SIN[0:7]
- When POS_MODE[0]=1 : Value interprets SIN[10:5]

	Bit7	Bit6	Bit5	Bit4	Bit3	Bit2	Bit1	Bit0
30h	0	0	D5	D4	D3	D2	D1	D0
R/W	R	R	R	R	R	R	R	R

[31h : Y positional value axially]

Name: POSY

Address: 31h

Description: This represents the Y-position of the press. The value is calculated differently depending on the matrix arrangement. For example when:

- When POS_MODE[0]=0 : Value interprets SIN[8:15]
- When POS_MODE[0]=1 : Value interprets SIN[11:4:12:3:13:2:14:1:15:0]

	Bit7	Bit6	Bit5	Bit4	Bit3	Bit2	Bit1	Bit0
31h	0	D6	D5	D4	D3	D2	D1	D0
R/W	R	R	R	R	R	R	R	R

[32h / 33h : Button ON/OFF]

Name: BTN

Address: 32h, 33h

Description: This is the state of the sensor when considered as an ON/OFF button. Here 1 : On. 0 : Off.

	Bit7	Bit6	Bit5	Bit4	Bit3	Bit2	Bit1	Bit0
32h	CH7	CH6	CH5	CH4	CH3	CH2	CH1	CH0
33h	CH15	CH14	CH13	CH12	CH11	CH10	CH9	CH8
R/W	R	R	R	R	R	R	R	R
Initial val.	0	0	0	0	0	0	0	0

[4* h : Offset Correction Data]

Name: OFFSET

Address: 4* h (one byte per sensor channel)

Description: This is the offset required to correct the sense data to half scale during the calibration procedure.

	Bit7	Bit6	Bit5	Bit4	Bit3	Bit2	Bit1	Bit0
4*h	OFS *[7]	OFS *[6]	OFS *[5]	OFS *[4]	OFS *[3]	OFS *[2]	OFS *[1]	OFS *[0]
R/W	R	R	R	R	R	R	R	R
Initial val.	1	0	0	0	0	0	0	0

【ECh : XY matrix setting】

Name: POS_MODE

Address: ECh

Description: Setting when two or more sensor are displayed to the first origin and position is detected.

XY : This selects between two matrix configurations.

1 = X axis → SIN [10 : 5] , Y axis → SIN [11:4:12:3:13:2:14:1:15:0]

0 = X axis → SIN [0 : 7] , Y axis → SIN [8:15]

POS_EN : The position tracking enable

Enables the condition under which the position tracking is made effective.

1=When either of sensor exceeds the threshold, the data of the position tracking is made effective.

If all registers do not exceed the threshold, the data of the position tracking is (POSX,POSY) = (0,0).

0=the position is detected regardless of the level of the sensor data, and data is made effective.

Initial state: When either of sensor exceeds the threshold, the positional detection data is made effective (=1).

	Bit7	Bit6	Bit5	Bit4	Bit3	Bit2	Bit1	Bit0
ECh	-	-	-	-	-	-	POS_EN	XY
R/W	-	-	-	-	-	-	W	W
Initial val.	-	-	-	-	-	-	1	1

【EEh : Soft Calibration】

Name: CALIB

Address: EEh

Description: This forces a chip re-calibration when a 1 is written and returns to 0 afterward automatically. Please note that one should always re-calibrate after changing the gain adjustment value.

	Bit7	Bit6	Bit5	Bit4	Bit3	Bit2	Bit1	Bit0
EEh	-	-	-	-	-	-	-	CALIB
R/W	-	-	-	-	-	-	-	W
Initial val.	-	-	-	-	-	-	-	0

【EFh : Setting Done, Detect Start】

Name: DONE

Address: EFh

Description: This register should be written to following register updates.

	Bit7	Bit6	Bit5	Bit4	Bit3	Bit2	Bit1	Bit0
EFh	-	-	-	-	-	-	-	DONE
R/W	-	-	-	-	-	-	-	W
Initial val.	-	-	-	-	-	-	-	0

【F0h / F1h : Sensor Channel Setting】

Name: SENS_CH

Address: F0h / F1h

Description: Individual enabling and disabling of sensor channels. 1 : Effective 0 : Not in use

	Bit7	Bit6	Bit5	Bit4	Bit3	Bit2	Bit1	Bit0
F0h	SIN7	SIN6	SIN5	SIN4	SIN3	SIN2	SIN1	SIN0
F1h	SIN15	SIN14	SIN13	SIN12	SIN11	SIN10	SIN9	SIN8
R/W	W	W	W	W	W	W	W	W
Initial val.	0	0	0	0	0	0	0	0

【F2h : LED Channel Setting】

Name: LED_CH

Address: F2h

Description: Enables and disables the channels to be used as LED outputs. Valid for the 8 LED outputs.

1 : Effective 0 : Not in use

	Bit7	Bit6	Bit5	Bit4	Bit3	Bit2	Bit1	Bit0
F2h	LED7	LED6	LED5	LED4	LED3	LED2	LED1	LED0
R/W	W	W	W	W	W	W	W	W
Initial val.	0	0	0	0	0	0	0	0

【F3h / F4h : Idle Exit Condition】

Name: IDLE_CHK

Address: F3h / F4h

Description: Defines which channels cause the device to wake up – i.e.

go from idle mode to normal operation on a key press. Selection is made on a per channel basis.

1 : Effective 0 : Not used

	Bit7	Bit6	Bit5	Bit4	Bit3	Bit2	Bit1	Bit0
F3h	SIN7	SIN6	SIN5	SIN4	SIN3	SIN2	SIN1	SIN0
F4h	SIN15	SIN14	SIN13	SIN12	SIN11	SIN10	SIN9	SIN8
R/W	W	W	W	W	W	W	W	W
Initial val.	1	1	1	1	1	1	1	1

【F5h : LED to Sensor Linkage】

Name: LED_LINK

Address: F5h

Description: Allows the LED outputs to be automatically linked to the input channels without need for any software control.

1 : It synchronizes with the button. 0 : It synchronizes with data (The register name: DLED) from host.

	Bit7	Bit6	Bit5	Bit4	Bit3	Bit2	Bit1	Bit0
F5h	LED7	LED6	LED5	LED4	LED3	LED2	LED1	LED0
R/W	W	W	W	W	W	W	W	W
Initial val.	1	1	1	1	1	1	1	1

【F6h : Sampling Interval】

Name: TIMES

Address: F6h

Description: Defines the sampling interval.

SAMP[1:0] : Sampling Interval :

Given by the following equation :

Sampling interval = system clock x 2¹³ x SAMP (Example: system clock 1[MHz] time : About 8.2[msec]).

	Bit7	Bit6	Bit5	Bit4	Bit3	Bit2	Bit1	Bit0
F6h	-	-	-	-	-	-	SAMP[1]	SAMP[0]
R/W	-	-	-	-	-	-	W	W
Initial val.	-	-	-	-	-	-	0	0

【F7h : Button OFF→ON Threshold】

Name: TH_ON2

Address: F7h

Description: A second threshold value for determining a button off→on judgment of sensor.

The sensor output value of 8bit (register SENS_DATA) is compared with 128+ ON2 [6:0], and if it is larger, the button is determined active.

	Bit7	Bit6	Bit5	Bit4	Bit3	Bit2	Bit1	Bit0
F7h	-	ON2[6]	ON2[5]	ON2[4]	ON2[3]	ON2[2]	ON2[1]	ON2[0]
R/W	-	W	W	W	W	W	W	W
Initial val.	-	0	0	1	0	0	0	0

【F8h / F9h : Button OFF→ON Threshold Selection】

Name: TH_ON2_CH

Address: F8h / F9h

Description: This register is used to relate either threshold TH_ON or TH_ON2 to particular sensor channels for button press activity determination.

1 : TH_ON2 is applied 0 : TH_ON is applied

	Bit7	Bit6	Bit5	Bit4	Bit3	Bit2	Bit1	Bit0
F8h	SIN7	SIN6	SIN5	SIN4	SIN3	SIN2	SIN1	SIN0
F9h	SIN15	SIN14	SIN13	SIN12	SIN11	SIN10	SIN9	SIN8
R/W	W	W	W	W	W	W	W	W
Initial val.	0	0	0	0	0	0	0	0

【FAh : Simultaneous Press and Idle Mode Entry】

Name: CMD
 Address: FAh
 Description:

INTERMIT_EN : Intermittent and the drive are enable. :

Whether intermittent is driven at the idol mode is selected.

1 : Intermittent is driven. 0 : Intermittent is not driven. Initial state : Intermittent is driven.

IDLE_T[3:0] : non-detect time-out setting :

This sets the time the chip takes to go from normal mode to idle mode in a period key inactivity.

Duration = system clock x 2¹⁹ x IDLE_T (Example of system clock 1[MHz]time : About 520[msec])

	Bit7	Bit6	Bit5	Bit4	Bit3	Bit2	Bit1	Bit0
FAh	-	-	-	INTERMIT_EN	IDLE_T[3]	IDLE_T[2]	IDLE_T[1]	IDLE_T[0]
R/W	-	-	-	W	W	W	W	W
Initial val.	-	-	-	1	0	1	1	1

【FBh : Gain Setting, Filter Function】

Name: GAIN_FILTER
 Address: FBh
 Description: Gain adjustment and setting of noise filter function.

GAIN[2:0] : gain setting :

It uses it for the gain adjustment in eight stages. Initial adjustment value : x1

GAIN[2:0]	000	001	010	011	100	101	110	111
Adjustment value	x 1	x 4.22	x 8.4	x 16.5	x 23	x 46	x 69	x 92

FILTER_EN : Filter enable :

Enables/disables setting of noise filter function

1 : enabled 0 : disabled Initial state : disabled

DELTA[3:0] : Filter follow count setting :

The follow count to which the noise filter function is effective is set.

	Bit7	Bit6	Bit5	Bit4	Bit3	Bit2	Bit1	Bit0
FBh	GAIN[2]	GAIN [1]	GAIN[0]	FILTER_EN	DELTA[3]	DELTA[2]	DELTA[1]	DELTA[0]
R/W	W	W	W	W	W	W	W	W
Initial val.	0	0	0	0	0	0	1	0

【FCh : Switch OFF -> ON Threshold】

Name: TH_ON
 Address: FCh
 Description: This register provides a threshold value for determining if a sensor has transitioned from OFF to ON.
 This is relative value from reference value (128d). So the absolute value of threshold is 128d + ON[6:0].
 It makes a threshold value between TH_ON and TH_OFF.
 TH_ON must be bigger than TH_OFF (TH_ON >= TH_OFF)
 Maximum threshold is 256d and minimum value is 128d.

	Bit7	Bit6	Bit5	Bit4	Bit3	Bit2	Bit1	Bit0
FCh	-	ON[6]	ON[5]	ON[4]	ON[3]	ON[2]	ON[1]	ON[0]
R/W	-	W	W	W	W	W	W	W
Initial val.	-	0	0	1	0	0	0	0

【FDh : Switch ON -> OFF Threshold Value】

Name: TH_OFF

Address: FDh

Description: This register provides a threshold value for transitioning from ON to OFF.

This is relative value from reference value (128d). So absolute value of threshold is 128d + OFF[6:0].

It makes a threshold value between TH_ON and TH_OFF.

TH_OFF must be smaller than TH_ON (TH_OFF =< TH_ON)

Maximum value is 256d and minimum value is 128d.

	Bit7	Bit6	Bit5	Bit4	Bit3	Bit2	Bit1	Bit0
FDh	-	OFF[6]	OFF[5]	OFF[4]	OFF[3]	OFF[2]	OFF[1]	OFF[0]
R/W	-	W	W	W	W	W	W	W
Initial val.	-	0	0	0	0	0	0	1

【FEh : LED Port Data】

Name: DLED

Address: FEh

Description: When LED is not linked with the sensor, it becomes a simple digital output that controls the LED.

1 : Light. 0 : Turned off.

	Bit7	Bit6	Bit5	Bit4	Bit3	Bit2	Bit1	Bit0
FEh	D7	D6	D5	D4	D3	D2	D1	D0
R/W	W	W	W	W	W	W	W	W
Initial val.	0	0	0	0	0	0	0	0

● Operation mode

This IC has a normal mode, idle mode and a shutdown mode as states of operation.

【Normal mode】

This is the normal operation of the device. Output pin INT="L".

【Idle mode】

This is the mode when the normal mode times out due to inactivity on the keys. In this mode the control interface is still alive.

*Usually time-out is aimed at about 200msec or less.

*Transition between normal and idle modes is automatic and without software control.

【Shutdown mode】

In this mode the device is completely stopped – and reset. This is achieved by making the terminal SDN L. All analog circuits and the logic circuits are stopped. The return from the shutdown mode returns by making the terminal SDN H.

*After shut-down all registers have their default values.

● Interface and system clock selection

I/F selection with MODE [1:0] pin. System clock selection by RXD.

【Using 2wires serial bus mode (MODE [1:0] =00b)】

The 2wires serial bus is used for host I/F.

RXD=0 in the system clock: Built-in oscillator is used.

RXD=1 in the system clock: The clock input from CLK_EXT is used.

● Initialization procedure

A normal power on sequence is:

- (1) Power on
- (2) Setup the registers
- (3) Write '1' to 0xEF (done register)

<sensing operation begins after auto-calibration occurs>

● Power supply turning on procedure

You should always power on DVDD at the same time as AVDD or before AVDD.

●Ordering part number

B	U	2	1	0	0	9	M	U	V	-	E	2
Part No		Part No					Package MUV : VQFN032V5050			Packaging and forming specification E2 : Embossed tape and reel		

VQFN032V5050

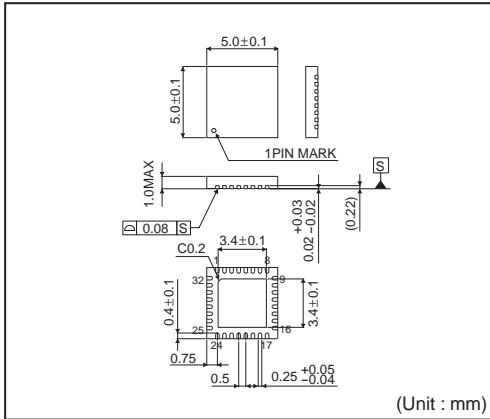

<Tape and Reel information>

Tape	Embossed carrier tape
Quantity	2500pcs
Direction of feed	E2 (The direction is the 1pin of product is at the upper left when you hold reel on the left hand and you pull out the tape on the right hand)

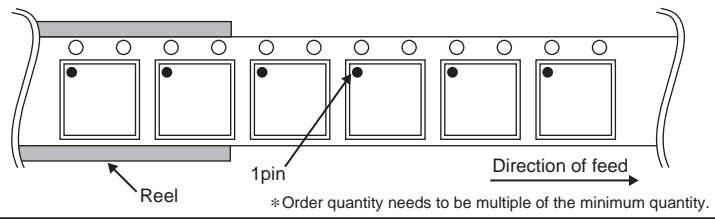

Notes

No copying or reproduction of this document, in part or in whole, is permitted without the consent of ROHM Co.,Ltd.

The content specified herein is subject to change for improvement without notice.

The content specified herein is for the purpose of introducing ROHM's products (hereinafter "Products"). If you wish to use any such Product, please be sure to refer to the specifications, which can be obtained from ROHM upon request.

Examples of application circuits, circuit constants and any other information contained herein illustrate the standard usage and operations of the Products. The peripheral conditions must be taken into account when designing circuits for mass production.

Great care was taken in ensuring the accuracy of the information specified in this document. However, should you incur any damage arising from any inaccuracy or misprint of such information, ROHM shall bear no responsibility for such damage.

The technical information specified herein is intended only to show the typical functions of and examples of application circuits for the Products. ROHM does not grant you, explicitly or implicitly, any license to use or exercise intellectual property or other rights held by ROHM and other parties. ROHM shall bear no responsibility whatsoever for any dispute arising from the use of such technical information.

The Products specified in this document are intended to be used with general-use electronic equipment or devices (such as audio visual equipment, office-automation equipment, communication devices, electronic appliances and amusement devices).

The Products specified in this document are not designed to be radiation tolerant.

While ROHM always makes efforts to enhance the quality and reliability of its Products, a Product may fail or malfunction for a variety of reasons.

Please be sure to implement in your equipment using the Products safety measures to guard against the possibility of physical injury, fire or any other damage caused in the event of the failure of any Product, such as derating, redundancy, fire control and fail-safe designs. ROHM shall bear no responsibility whatsoever for your use of any Product outside of the prescribed scope or not in accordance with the instruction manual.

The Products are not designed or manufactured to be used with any equipment, device or system which requires an extremely high level of reliability the failure or malfunction of which may result in a direct threat to human life or create a risk of human injury (such as a medical instrument, transportation equipment, aerospace machinery, nuclear-reactor controller, fuel-controller or other safety device). ROHM shall bear no responsibility in any way for use of any of the Products for the above special purposes. If a Product is intended to be used for any such special purpose, please contact a ROHM sales representative before purchasing.

If you intend to export or ship overseas any Product or technology specified herein that may be controlled under the Foreign Exchange and the Foreign Trade Law, you will be required to obtain a license or permit under the Law.



Thank you for your accessing to ROHM product informations.
More detail product informations and catalogs are available, please contact us.

ROHM Customer Support System

<http://www.rohm.com/contact/>