

REV.	DATE	ECR NO.	DESCRIPTION
NC	10/15/10	XXXXXX	INITIAL RELEASE
A	11/14/13	2557	CHANGE MOUNTING HARDWARE TO PASSIVATED STAINLESS STEEL, ADD ELECTRICAL/MECHANICAL NOTES, UPDATED DRAWING FORMAT

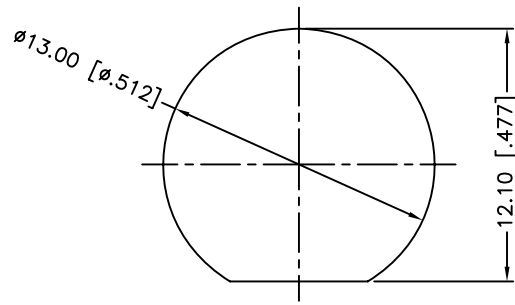

RECOMMENDED MOUNTING HOLE

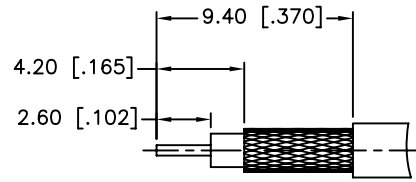

RECOMMENDED CABLE STRIPPING DIM'S

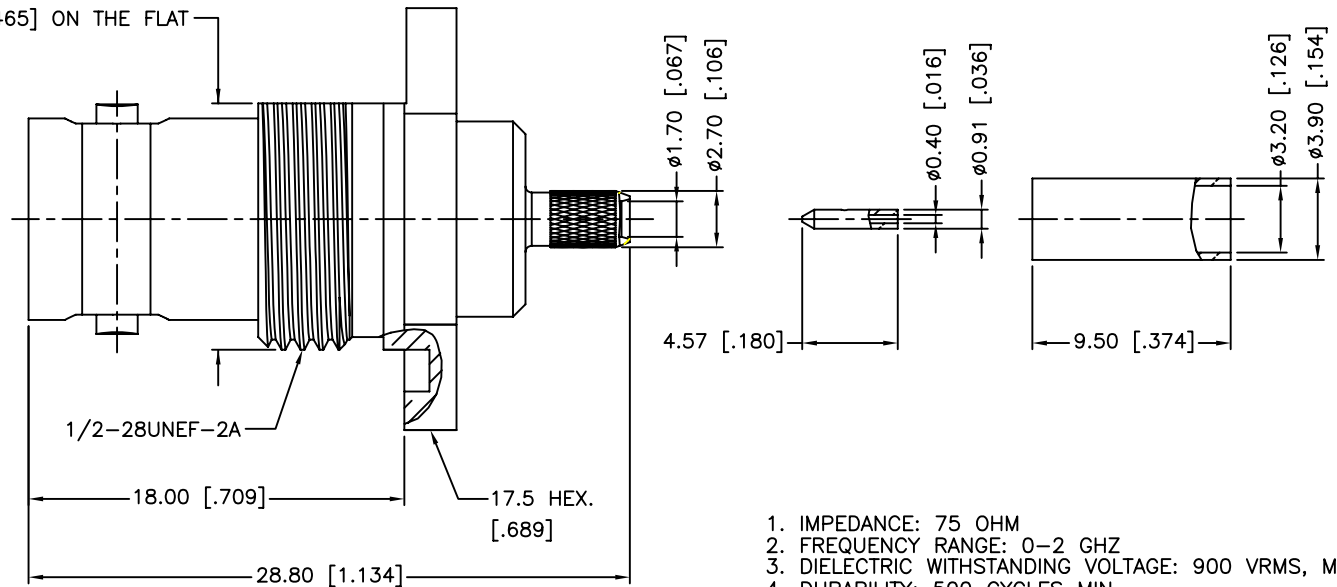
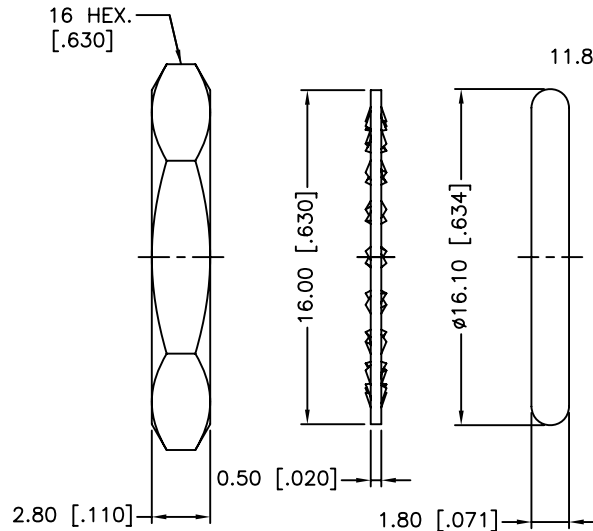
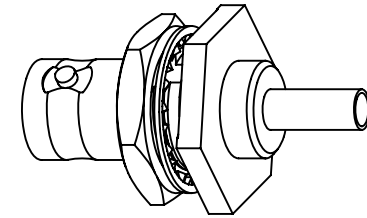

1. IMPEDANCE: 75 OHM
2. FREQUENCY RANGE: 0-2 GHZ
3. DIELECTRIC WITHSTANDING VOLTAGE: 900 VRMS, MIN.
4. DURABILITY: 500 CYCLES MIN.
5. TEMPERATURE RANGE: -65°C TO +165°C
6. CRIMPED FERRULE  
HEX. CRIMP SIZE .128"
7. CRIMPED CONTACT PIN  
USE 4-WAY INDENT CRIMP TOOL #47025
8. MAX. PANEL THICKNESS=3.5mm

QTY	DESCRIPTION	MATERIAL	FINISH
1	HEX NUT	STAINLESS STEEL	PASSIVATED
1	LOCK WASHER	STAINLESS STEEL	PASSIVATED
1	GASKET	SILICONE RUBBER	RED
1	FERRULE	BRASS	NICKEL
1	CONTACT PIN	BRASS	GOLD
1	RETAINING RING	BRASS	NICKEL
1	CONTACT PIN	PHOSPHOR BRONZE	GOLD
1	GASKET	SILICONE RUBBER	RED
1	INSULATOR	PTFE	NATURAL
1	BODY	BRASS	NICKEL
QTY	DESCRIPTION	MATERIAL	FINISH

UNLESS OTHERWISE SPECIFIED DIMENSIONS ARE IN MILLIMETERS. DIMENSIONS IN [ ] ARE IN INCHES AND FOR CUSTOMER REFERENCE ONLY.  
 TOLERANCES FOR MILLIMETERS ARE:  
 <0.5 ± 0.05mm  
 0.5 - 6mm ± 0.10mm  
 6 - 30mm ± 0.20mm  
 30 - 120mm ± 0.30mm  
 ANGLES ± 1°  
 UNLESS OTHERWISE SPECIFIED TOLERANCES FOR INCHES ARE:  
 <.020 ± 0.002"  
 .020 - .236 ± 0.004"  
 .236 - 1.180 ± 0.007"  
 1.180 - 4.724 ± 0.012"  
 ANGLES ± 1°  
 DO NOT SCALE DRAWING

APPROVALS	DATE
DRAWN M.ZHANG	11/14/13
CHECKED	
ISSUED	
SHEET 1 OF 1	
CAD FILE C:/CONNEX/112235-12.DWG	

# Amphenol Connex

PART DESCRIPTION	
75 OHM BNC BULKHEAD CRIMP JACK IP-67 COMPLIANT (FOR RG-179/U CABLE)	
PART NO.	
112235-12	
DWG. NO.	REV.
112235-12.DWG	A
SIZE	SCALE
A	NA