

- NOTE) 1. ALL LEAD CO-PLANARITY SHALL BE 0.08mm MAX
 2. CONTACT PLATING SPECIFICATIONS.
 CONTACT AREA : GOLD $0.05 \mu\text{m}$ MIN
 SMT LEAD : GOLD $0.05 \mu\text{m}$ MIN
 UNDERPLATING : NICKEL $1 \mu\text{m}$ MIN
 (SURFACE : SEALING)
 3. EACH CONTACTS AT 4 CORNERS ARE PROVIDED FOR METAL FITTINGS AND GROUNDING PURPOSE.
 4. HRS MARK AND CAV NO. ARE INDICATED IN APPROX POSITION SHOWN.
 5. GATE POSITION IS INDICATED IN APPROX POSITION SHOWN.

NO.	MATERIAL	FINISH	REMARKS	NO.	MATERIAL	FINISH	REMARKS
3	PS		CLEAR (ENBOSSED CARRIER TAPE)	7	PS		CLEAR (REINFORCEMENT COLLAR)
2	PHOSPHOR BRONZE	2		6	POLYIMIDE		BROWN (HEAT RESISTANCE TAPE)
1	LCP		UL94 V-0, BLACK	5	PS		BLACK (PLASTIC REEL)
				4	POLYESTER		CLEAR (COVER TAPE)

UNITS	SCALE	COUNT	DESCRIPTION OF REVISIONS	DESIGNED	CHECKED	DATE
mm	10:1	1				
APPROVED : KH. IKEDA			11.04.11	DRAWING NO. EDC3-319843-02		
CHECKED : AR. TAKAHASHI			11.04.08	PART NO. BM14B(0.8)-40DS-0.4V(52)		
DESIGNED : SH. HOSODA			11.04.08	CODE NO. CL684-8008-9-52		
DRAWN : KR. AJITO			11.04.06	1/3		

◆ RECOMMENDED PCB LAYOUT

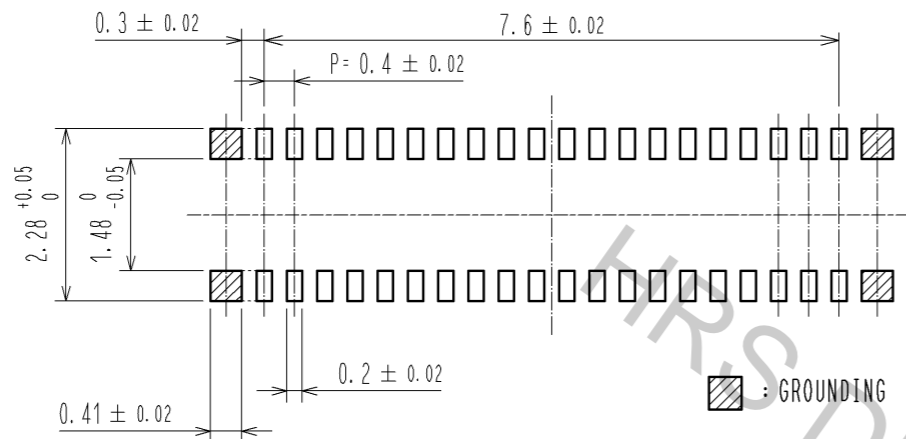

◆ RECOMMENDED METAL MASK DIMENSIONS

METAL MASK THICKNESS : 100 μm

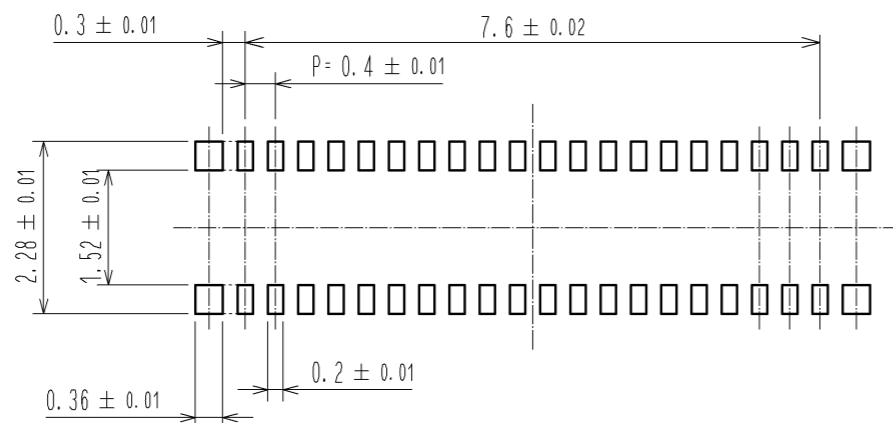

⑥ RECOMMENDED REFLOW TEMPERATURE PROFILE USING LEAD-FREE SOLDER PASTE.

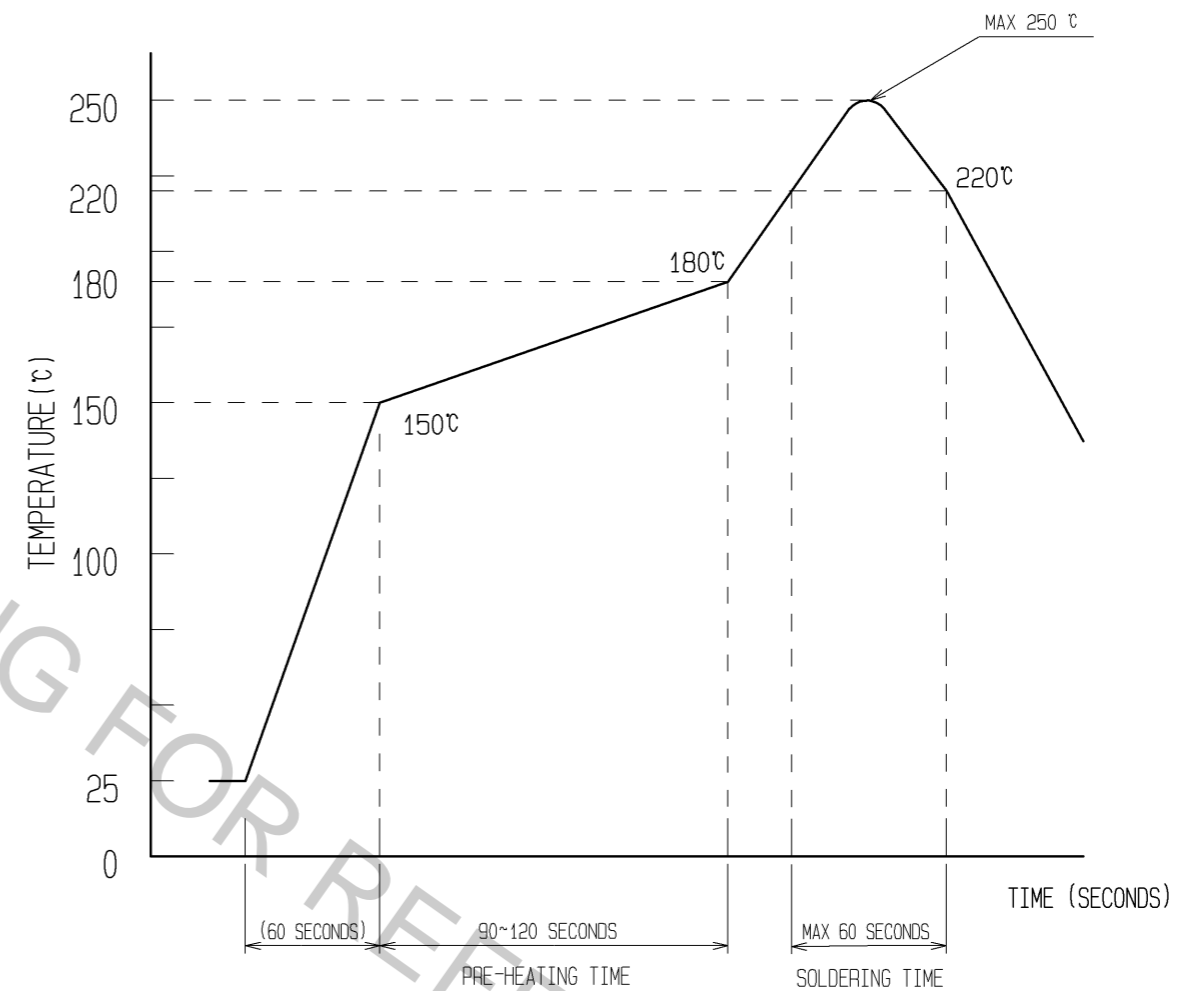

- REFLOW METHOD: IR REFLOW.
 NUMBER OF REFLOW CYCLES: 2 CYCLES MAX.
- REFLOW TIME
 DURATION ABOVE 220°C, 60 SEC. MAX.
 (PEAK TEMPERATURE: 250°C MAX)
 - PRE-HEAT TIME
 PRE-HEAT TEMPERATURE(MIN): 150°C
 PRE-HEAT TEMPERATURE(MAX): 180°C
 PRE-HEAT TIME: 90-120 sec.

⑥ THIS TEMPERATURE PROFILE IS PER THE CONDITIONS SHOWN ABOVE. ADDITIONAL FACTORS, SUCH AS SOLDER PASTE TYPE, PCB SIZE AND OTHER MOUNTED COMPONENTS COULD AFFECT THE PROFILE, THEREFORE, A THOROUGH EVALUATION OF MOUNTING CONDITION IS REQUIRED PRIOR TO PRODUCTION. TEMPERATURE IS MEASURED AT CONTACT LEAD.

HRS	DRAWING NO.	EDC3-319843-02
	PART NO.	BM14B(0.8)-40DS-0.4V(52)
	CODE NO.	CL684-8008-9-52

△ 2/3

EMBOSSED CARRIER TAPE PACKAGING (5:1)

STYLE AND DIMENTION OF REEL (FREE)

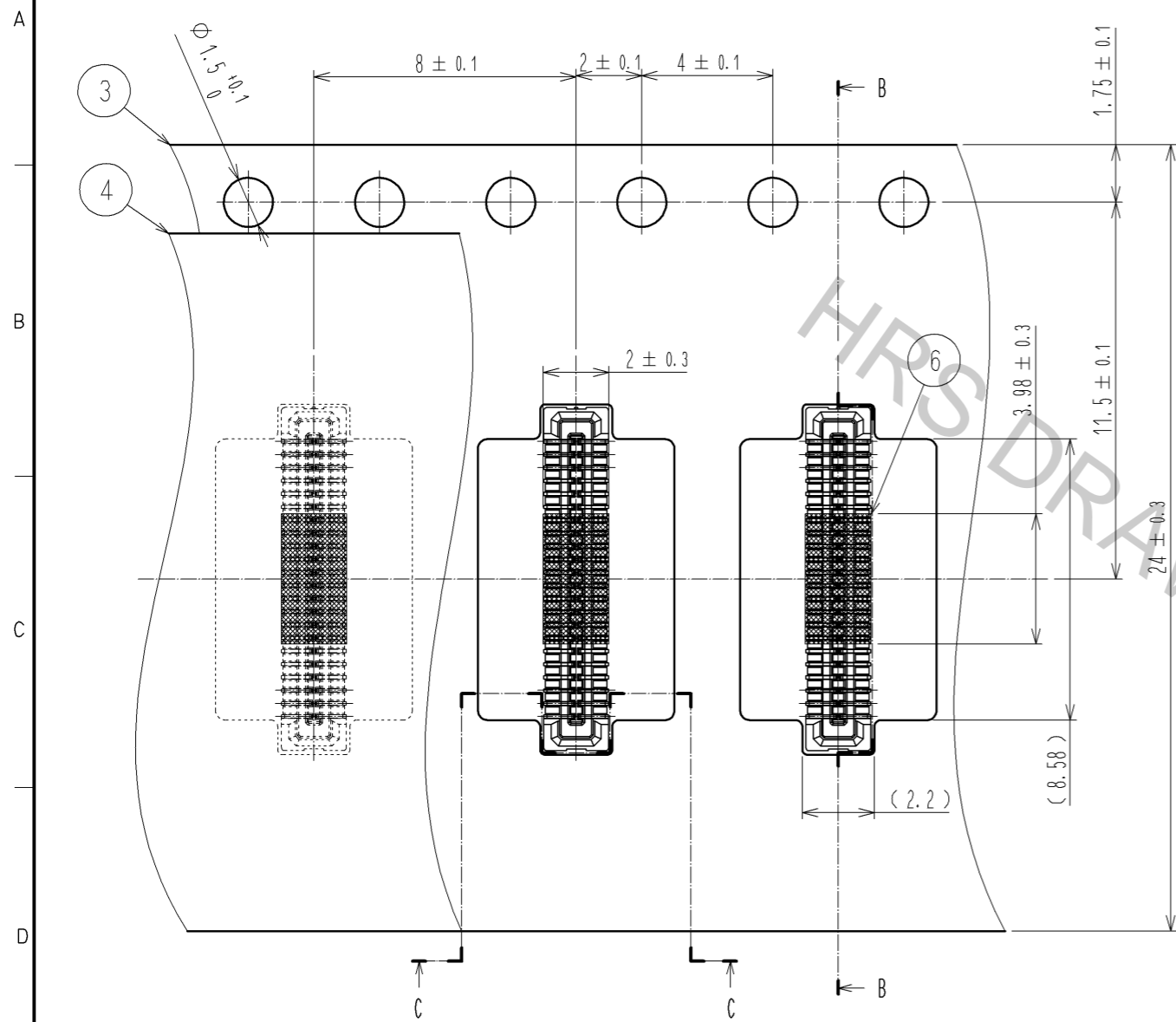

B-B (5:1)

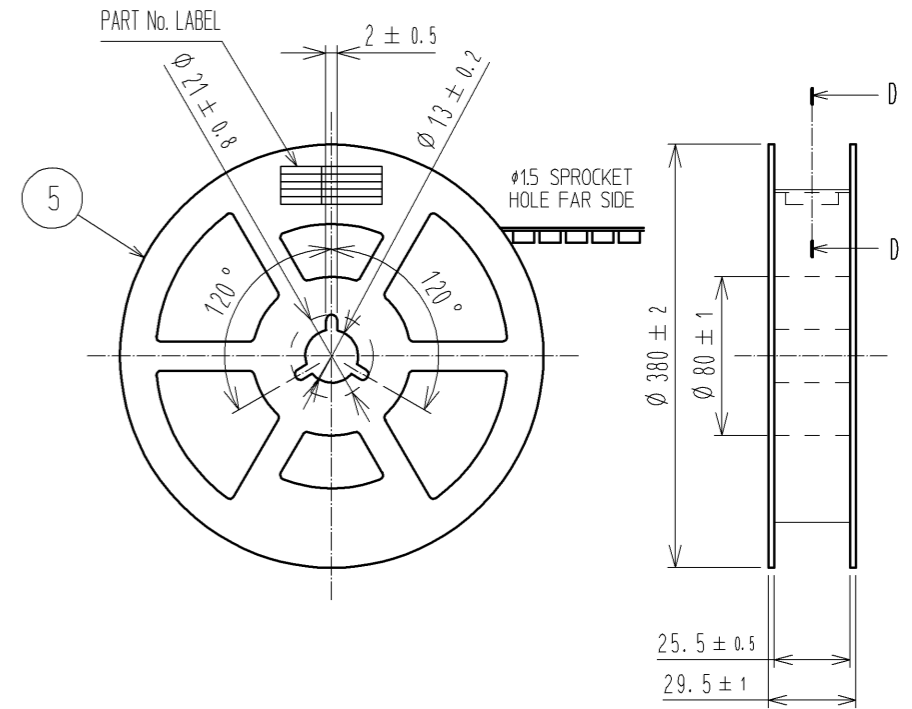
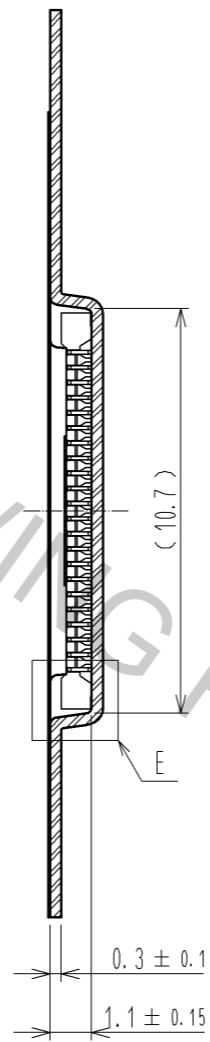

DETAIL OF PART No. LABEL

製造年月日	** ** *	DATE OF MANUFACTURED
製品コード	CL0684-8008-9-(52)	CODE No.
製品名	BM14B(0.8)-40DS-0.4V(52)	PART No.
数量	8,000	QUANTITY
納入者	ヒロセ電機(株)	SUPPLIER

DATE OF MANUFACTURED
CODE No.
PART No.
QUANTITY
SUPPLIER

E(10:1)

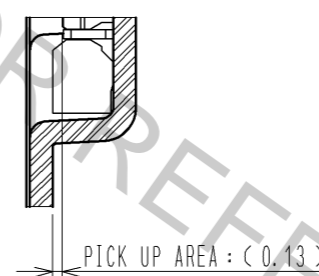

C-C (5:1)

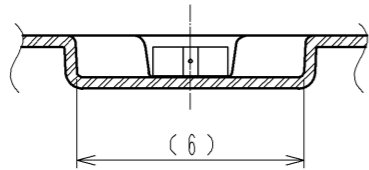

D-D (FREE)

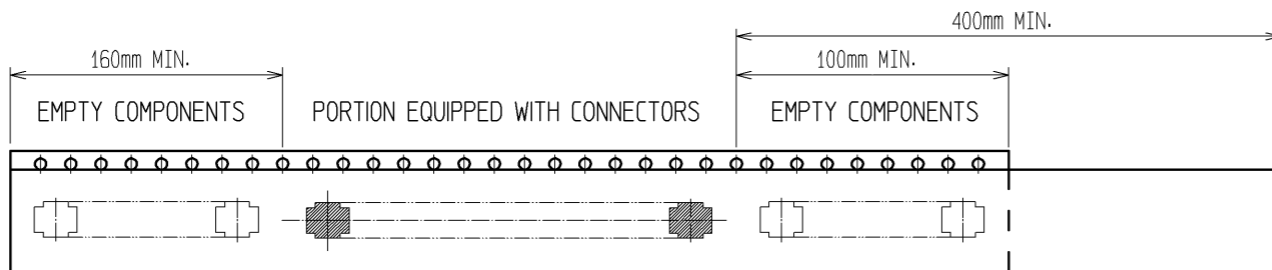
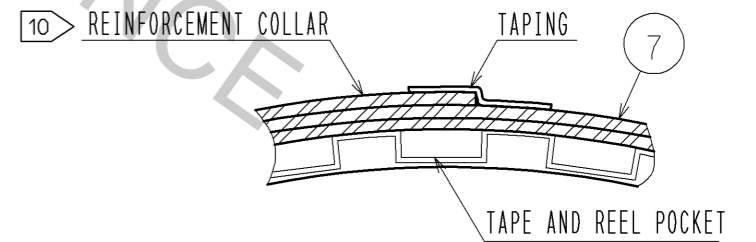

- 7. PER REEL 8000 CONNECTORS.
- 8. THE DIMENSIONS IN PARENTHESES ARE FOR REFERENCE.
- 9. REFER TO JIS C 0806(PACKAGING OF COMPONENTS FOR AUTOMATIC HANDLING)
- 10. AFTER PACKAGING, ROLL 2 METERS OF THE REINFORCEMENT COLLAR TO OUTER CIRCUMFERENCE OF TAPE AND REEL POCKET, AND TAPE DOWN AT THE END THE COLLAR.

HRS	DRAWING NO.	EDC3-319843-02
	PART NO.	BM14B(0.8)-40DS-0.4V(52)
	CODE NO.	CL684-8008-9-52
		$\triangle 3/3$