

REV	ECN	APP'D
-	5428	JT 3/24/04
A	6689	<i>[Signature]</i>

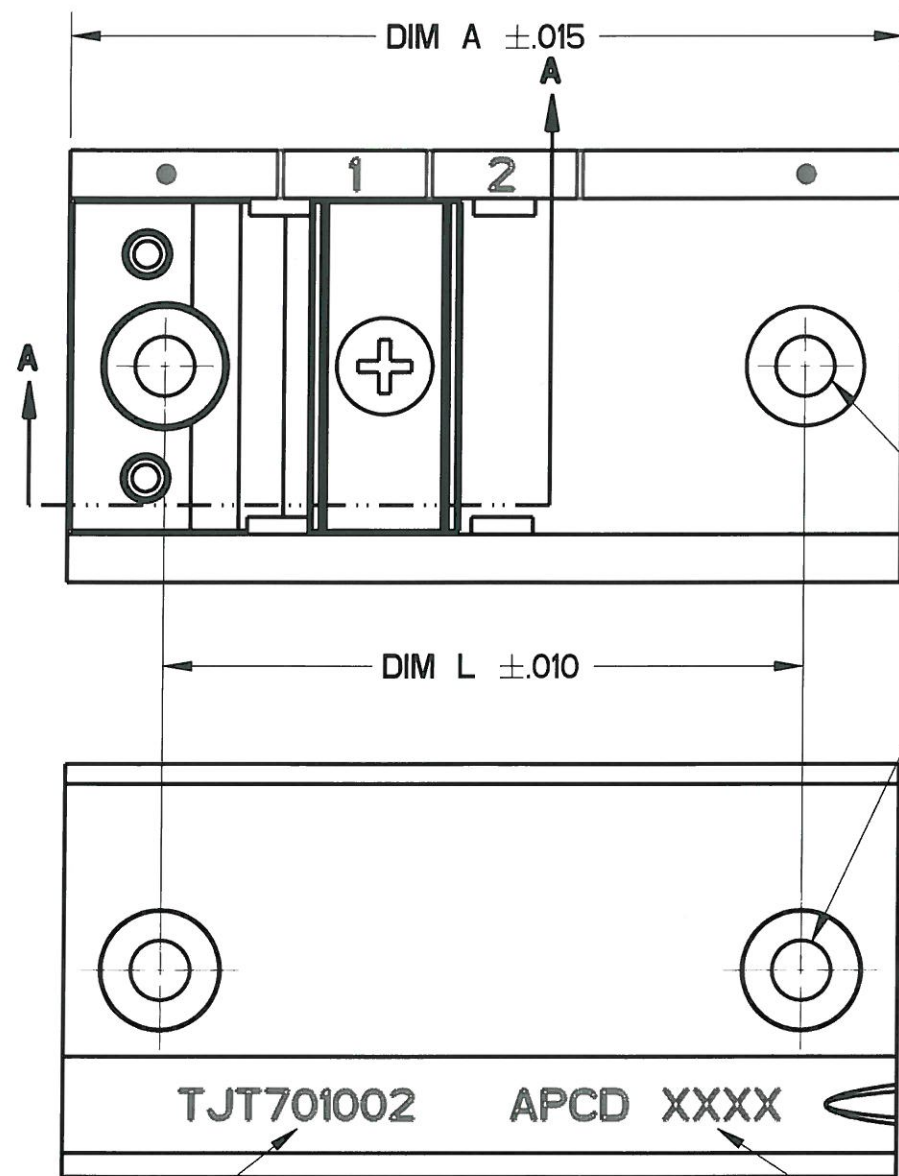

Ø.154 MOUNTING HOLES
CSK 82° X .307 DIA
4X

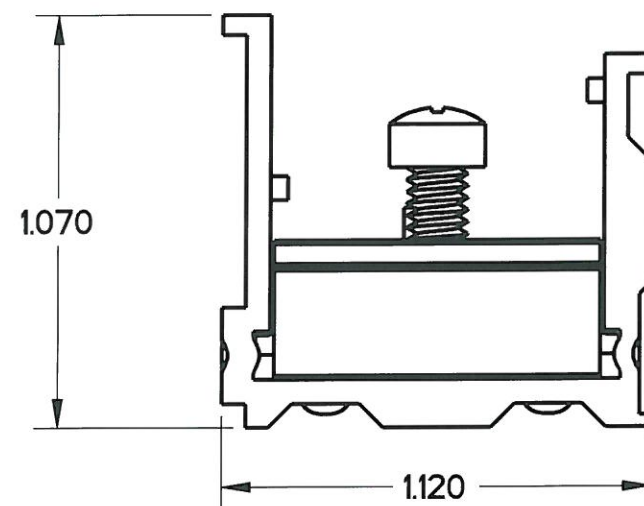

NOTES:

- MATERIALS AND FINISH
TRACK, LOCKING CLAMP, AND END STOP - ALUMINUM ALLOY 6063
TEMPER T5, PER FED SPEC. QQ-A-200/9, BLACK ANODIZE PER MIL-A-8625
TYPE II, CLASS 2.
LOCKING CLAMP SCREW - CORROSION RESISTANT, PASSIVATED, SELF-LOCKING.
RIVETS - ALUMINUM ALLOY #2117, CHROMATE PER MIL-DTL-5541, CLASS 1A, YELLOW.
- PARTS CONFORM TO REQUIREMENTS OF M81714/5, EXCEPT NO. OF MOUNTING POSITIONS.
- APCD P/N TJT701002 SHOWN.

APCD P/N

DATE CODE

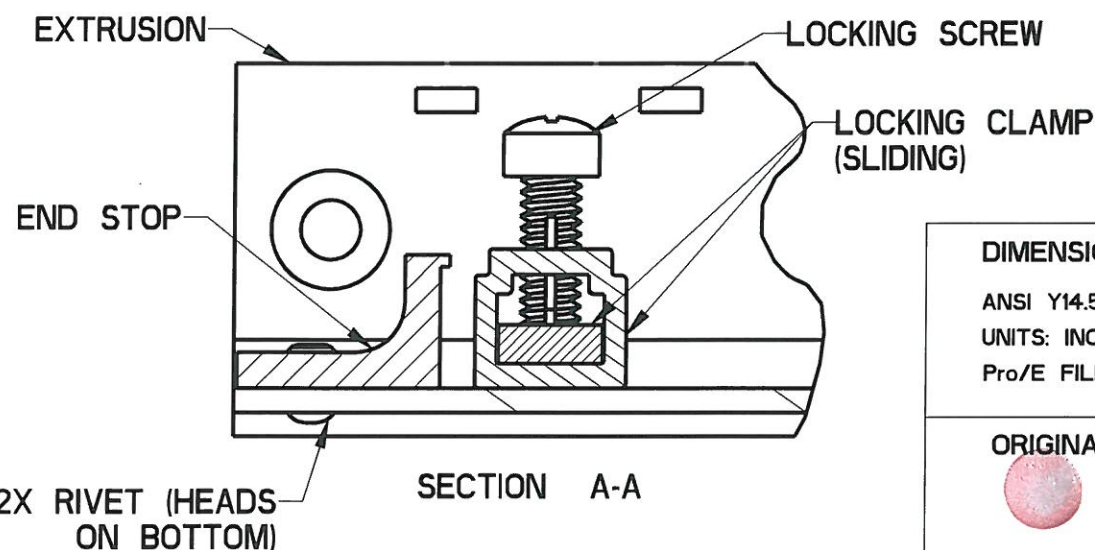

* DIVIDE BY 3 FOR SIZE 12 MODULE MOUNTING

APCD P/N	MTG POS*	DIM A	DIM L
TJT701002	2	2.171	1.671
TJT701016	16	7.631	7.131
TJT701017	17	8.021	7.521
TJT701018	18	8.411	7.911
TJT701019	19	8.801	8.301
TJT701020	20	9.191	8.691
TJT701021	21	9.581	9.081

DIMENSIONS ANSI Y14.5M UNITS: INCHES Pro/E FILE	TOLERANCES .XX ±0.01 .XXX ±0.005 ANGLES ±2.0°	PROJECTION 	Amphenol Pcd SPECIFICATION DRAWING ENGR S. KONDO 23-Mar-04		TITLE TERMINAL JUNCTION TRACK FEEDBACK - STANDARD	
			ORIGINAL 	THIS DOCUMENT CONTAINS PROPRIETARY INFORMATION WHICH IS THE CONFIDENTIAL PROPERTY OF AMPHENOL PCD INC. BEVERLY, MA, USA		CHKD <i>[Signature]</i> 4/18/11 APPD <i>[Signature]</i> 9/20/04

TJT701002

TJT701002