

NOTES:

1. MATERIALS AND FINISHES:
 BODY - BRASS, NICKEL PLATING
 CONTACT - BERYLLIUM COPPER, SILVER PLATING
 INSULATOR - PTFE
2. ELECTRICAL:
 A. IMPEDANCE: 50 OHM
 B. FREQUENCY RANGE: DC 0-4 GHz
 C. DIELECTRIC WITHSTANDING VOLTAGE: 1500 VRMS, MIN.
3. MECHANICAL:
 A. DURABILITY: 500 CYCLES MIN.
 B. TEMPERATURE RANGE: - 65°C to +165°C
4. THIS CONNECTOR ACCOMMODATES THE FOLLOWING CABLES :
 RG-55/U, 55A/U, 55B/U, 58/U, 58A/U, 58B/U, 58C/U,
 141/U, 141A/U, 142/U, 142B/U, 223/U, 400/U,142A/U

THIRD ANGLE PROJ.

REVISIONS

REV	DESCRIPTION	DATE	ECO	APPR
A	RELEASE TO MFG.	30-Oct-02	--	TONY
Y	REDRAWN TO UPDATE FORMAT	9-Dec-08	47238	SH
AA	STAMP "AMPHENOL" WAS "74868"\RD-DM11120601R3	26-Dec-11	48844	SH

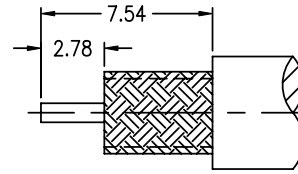

RECOMMENDED
CABLE STRIPPING DIM'S

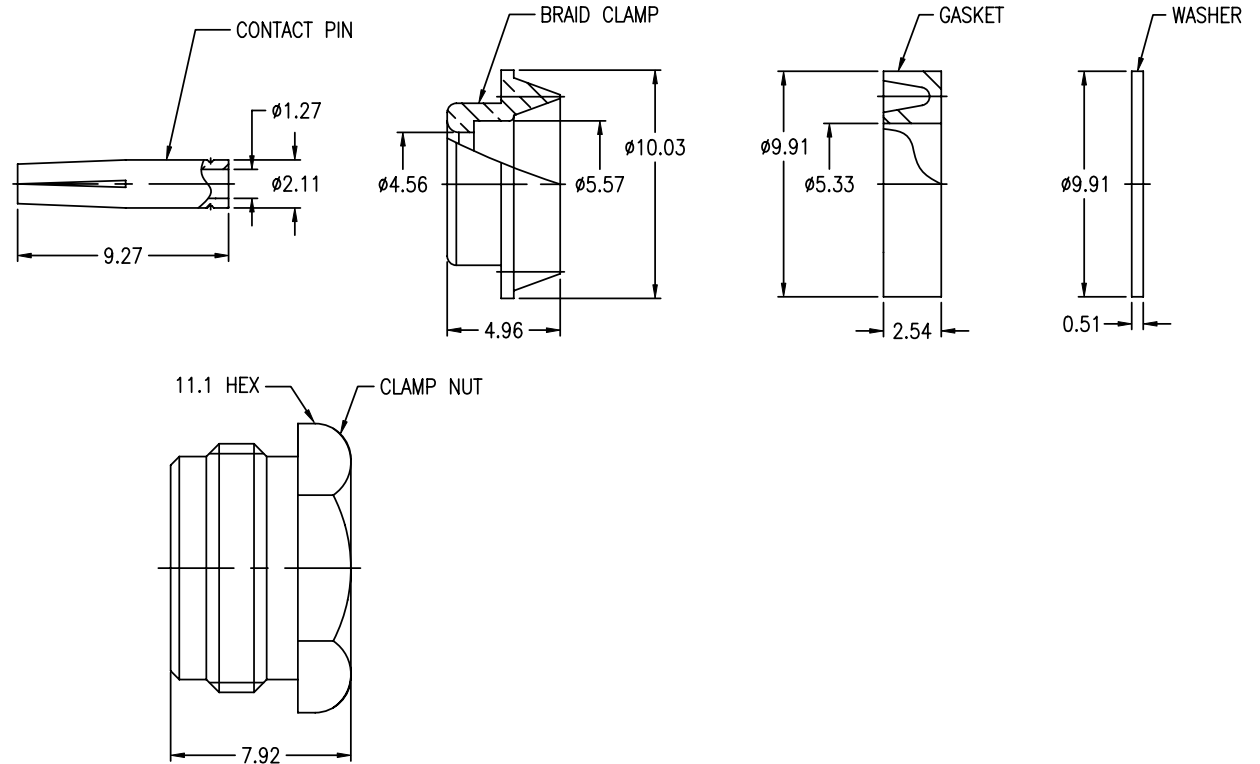
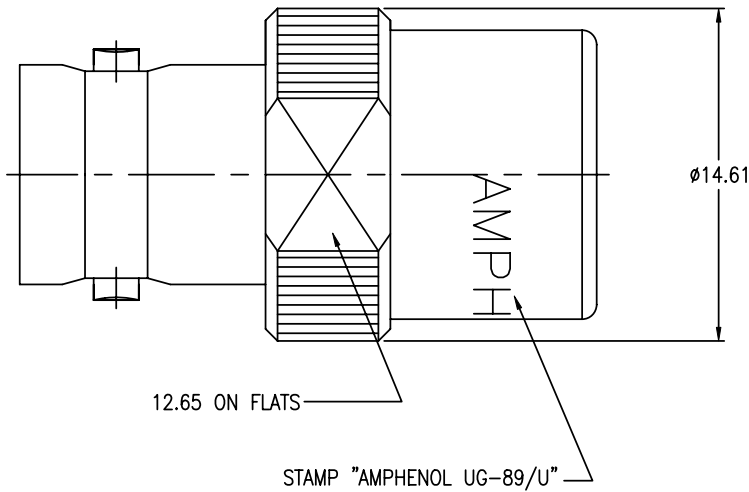

5. ASSEMBLY INSTRUCTIONS:

- A. PLACE NUT, WASHER AND GASKET (WITH 'V' GROOVE TOWARD OPEN END OF CABLE) OVER CABLE.
- B. TRIM TO RECOMMENDED STRIPPING DIMENSIONS.
- C. PULL BRAID WIRES FORWARD AND TAPER TOWARD CENTER CONDUCTOR. PLACE CLAMP OVER BRAID AND PUSH BACK AGAINST CABLE JACKET.
- D. FOLD BACK BRAID WIRES, CRIMP OR SOLDER ON CONTACT.
- E. INSERT CABLE AND PARTS TO CONNECTOR BODY, MAKE SURE SHARP EDGE OF CLAMP SEATS PROPERLY IN GASKET. TIGHTEN NUT.

CUSTOMER OUTLINE DRAWING

ALL OTHER SHEETS ARE FOR INTERNAL USE ONLY

UNLESS OTHERWISE SPECIFIED, DIMENSIONS ARE IN METRIC AND TOLERANCES ARE: 0.5 - 6mm ±0.1mm 6 - 30mm ±0.2mm 30 - 120mm ±0.3mm ANGLES ±1°	MATERIAL	DRAWN R. MAO	DATE 12-Dec-11	TITLE BNC JACK (FOR UG-89/U CABLE)			Amphenol RF		
	REFERENCE	ENGINEER RICHER	DATE 30-Oct-02				Danbury CT USA, Tainan Taiwan, Shenzhen China www.amphenolrf.com		
FINISH		APPROVED S. HSIEH	DATE 12-Dec-11	SCALE: 3/1	SHEET 2 OF 2		DRAWING NO.	31-5	
	CAD FILE F:\DWG\CNPD\31\5-AASZ			DWG SIZE B	CODE ID 74868	REV AA	ITEM NO.	31-5	
NOTICE - These drawings, specifications, or other data (1) are, and remain the property of Amphenol Corp. (2) must be returned upon request; and (3) are confidential and not to be disclosed to any person other than those to whom they are given by Amphenol Corp. The furnishing of these drawings, specifications, or other data by Amphenol Corp., or to any other person to anyone for any purpose is not to be regarded by implication or otherwise in any manner licensing, granting rights or permitting such holder or any other person to manufacture, use or sell any product, process or design, patented or otherwise, that may in any way be related to or disclosed by said drawings, specifications, or other data.						PART NO.	31-5		