

PART NAME: KNOB SCALE: 1:1 DATE: 4/11/07 DR. BY JAM

DAVIES MOLDING COMPANY
CAROL STREAM, ILLINOIS 60188

P/N 1505
BASE PART 1505-01
SET SCREW I2359

THIS DRAWING IS THE PROPERTY OF DAVIES MOLDING COMPANY, IS SUBMITTED SOLELY AS A DESIGN OR ENGINEERING PROJECT. WE ACCEPT NO RESPONSIBILITY WHATSOEVER FOR THE PRACTICAL APPLICATION OF THE PIECES MADE TO THIS DESIGN.

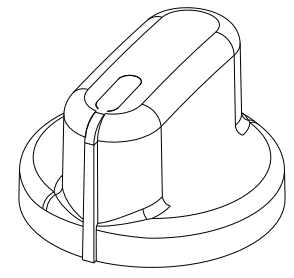
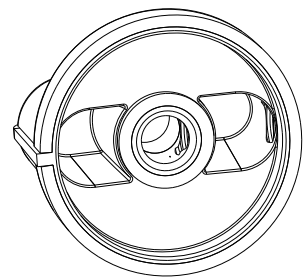
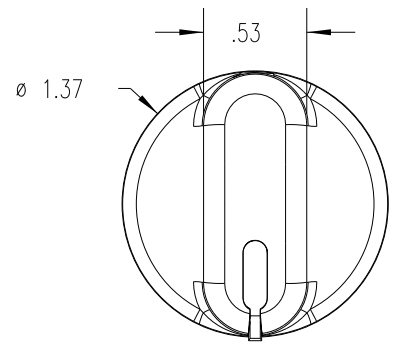

(A)
(B)

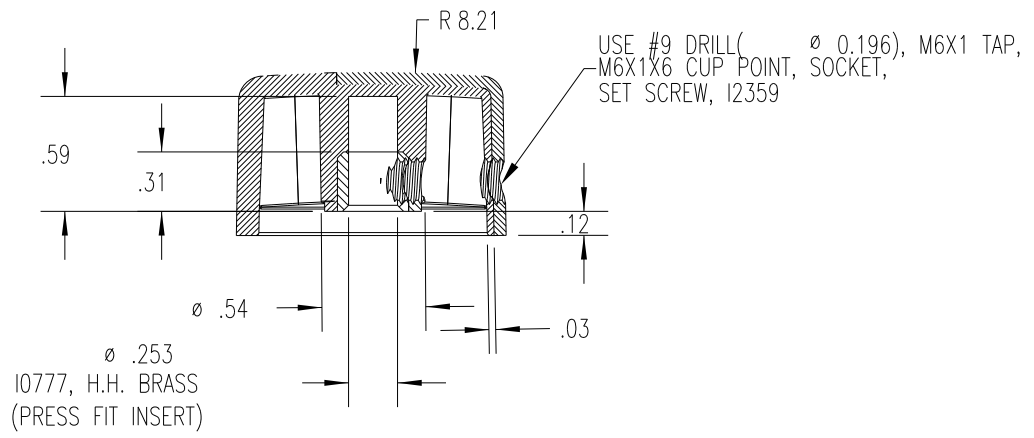
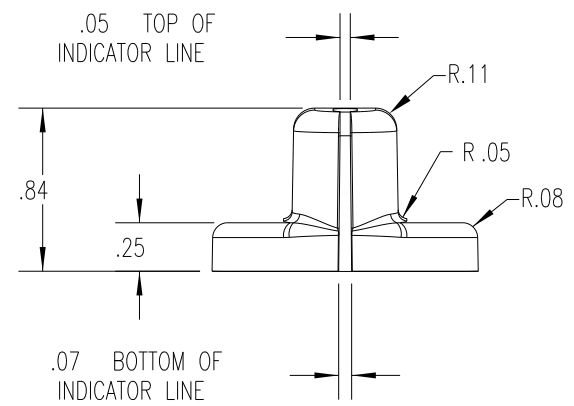

SECTION A-A

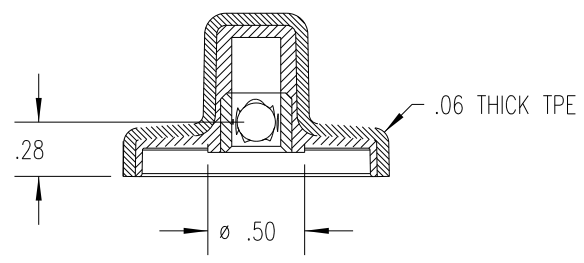
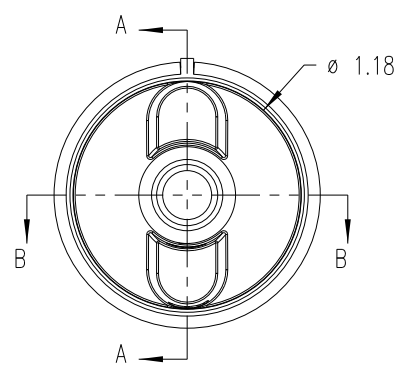

SECTION B-B

MATERIAL: SUBSTRATE: POLYPROPYLENE (CLD)
OVERMOLD: TPE (TPE3)
COLOR: SUBSTRATE: WHITE (PC23083)
OVERMOLD: BLACK (PC-301)

TOLERANCES: UNLESS OTHERWISE SPECIFIED	DO NOT SCALE DRAWING	B	ADDED BASE PART	JAM	1/31/14
DECIMALS: X.XXX ± .005 X.XX ± .015	MM: X.XX ± 0.15MM X.X ± 0.4MM	A	MOLD # WAS 2813	JAM	12/14/09
FRACTIONS ± 1/64	ANG. ± 1°	-	WAS SK1505-07	JAM	4/11/07
CHANGES					