

THIS DRAWING IS UNPUBLISHED. RELEASED FOR PUBLICATION
 © COPYRIGHT BY TYCO ELECTRONICS CORPORATION. ALL INTERNATIONAL RIGHTS RESERVED.

LOC	DIST	REVISIONS					
		P	LTR	DESCRIPTION	DATE	DWN	APVD
G	86		A	DRAWN	29OCT09	JR	TM

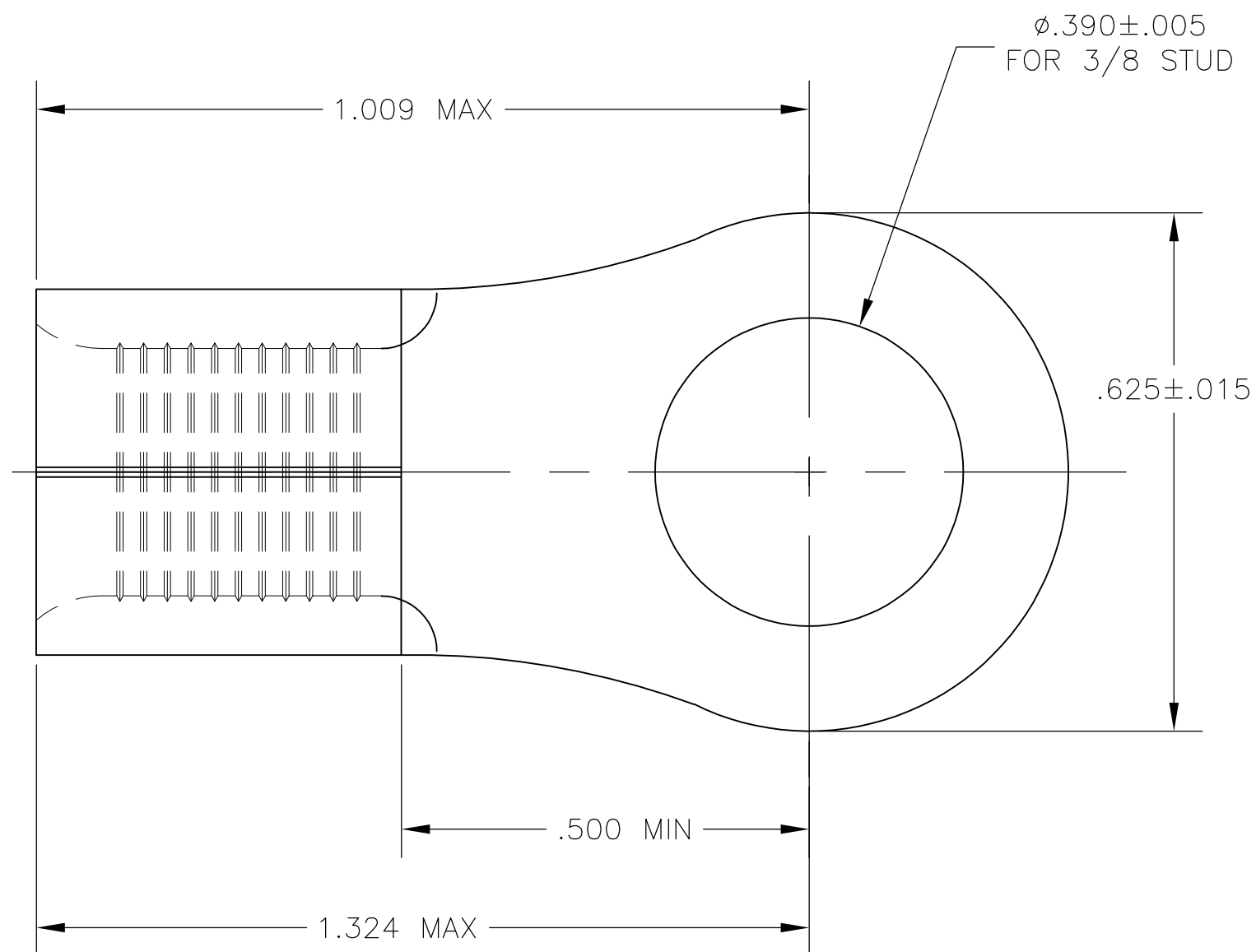

- 1 WIRE RANGE IS FOR #4 AWG STANDARD. WIRE CROSS SECTION OF AREA RANGE: 33,100-52,600 CMA, STRANDED WIRE
- 2 THE TONGUE THK IS .070±.003
- 3 RECOMMENDED OPERATING TEMP -55°C TO +200°C FOR HEAT SHRINK TUBING

QTY	PART NO	DESCRIPTION
1	1958321-1	HIGH AND LOW TEMPERTURE CROSS LINKED FLOUROPOLYMER HEAT SHRINK TUBING .500 MIN ID X 38mm±1.5mm, RT-555
1	31812-2	TERMINAL BODY: COPPER PER ASTM B-152 ANNEALED FINISH: NICKEL PLATE .000300 MIN THK PER SAE AMS QQ-N-290
-1	PART NO	DESCRIPTION

THIS DRAWING IS A CONTROLLED DOCUMENT.		DWN JR RUTH 29OCT09	Tyco Electronics Corporation Harrisburg, PA 17105-3608													
DIMENSIONS: INCHES		CHK TOM MICHIELUTTI 29OCT09	NAME HEAT RESISTANT TERMINAL KIT													
TOLERANCES UNLESS OTHERWISE SPECIFIED:		APVD TOM MICHIELUTTI 29OCT09	PRODUCT SPEC -													
<table border="1"> <tr><td>0 PLC</td><td>± -</td></tr> <tr><td>1 PLC</td><td>± -</td></tr> <tr><td>2 PLC</td><td>± -</td></tr> <tr><td>3 PLC</td><td>± -</td></tr> <tr><td>4 PLC</td><td>± -</td></tr> <tr><td>ANGLES</td><td>± 1°</td></tr> </table>		0 PLC	± -	1 PLC	± -	2 PLC	± -	3 PLC	± -	4 PLC	± -	ANGLES	± 1°	APPLICATION SPEC -	SIZE A3	CAGE CODE 00779
0 PLC	± -															
1 PLC	± -															
2 PLC	± -															
3 PLC	± -															
4 PLC	± -															
ANGLES	± 1°															
MATERIAL -	FINISH -	WEIGHT -	DRAWING NO G-696642	RESTRICTED TO -												
CUSTOMER DRAWING			SCALE 5:1	SHEET 1 OF 1												
			REV A													