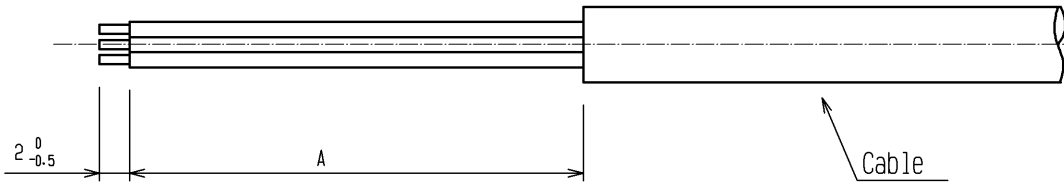
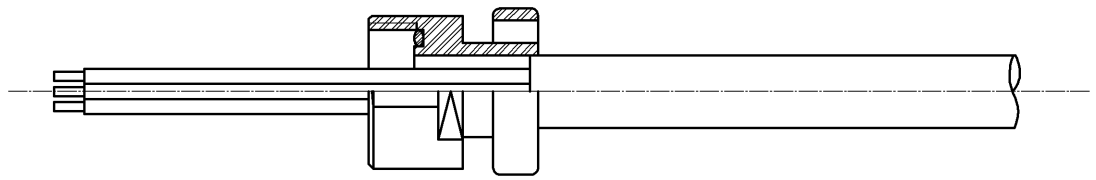
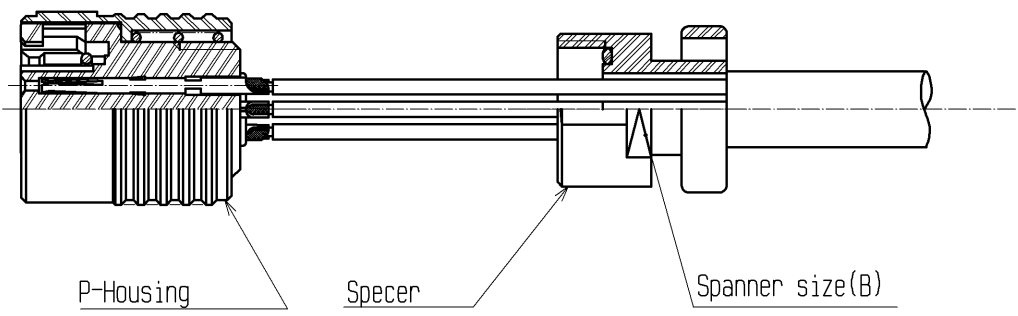
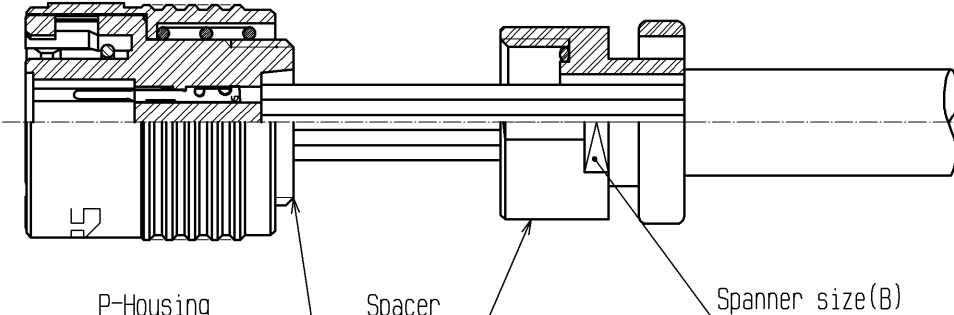
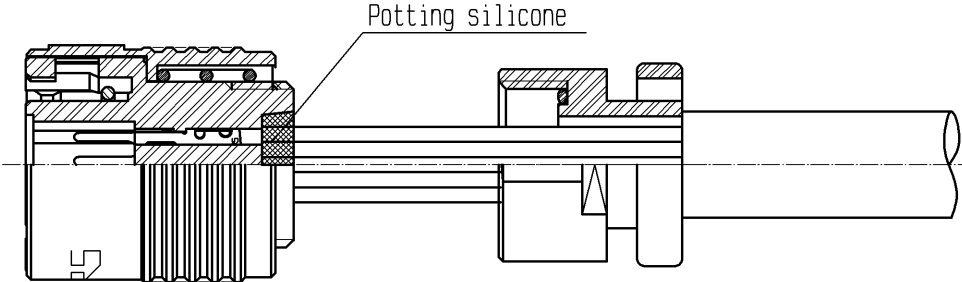
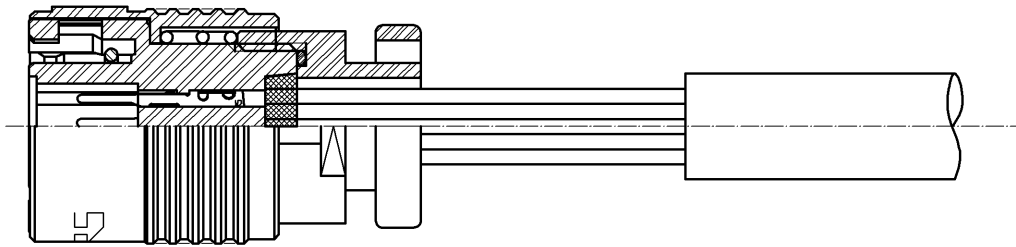
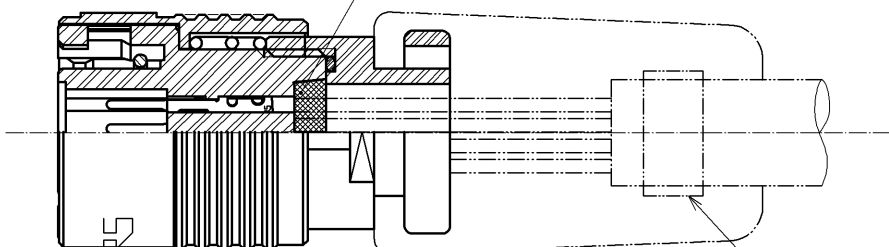
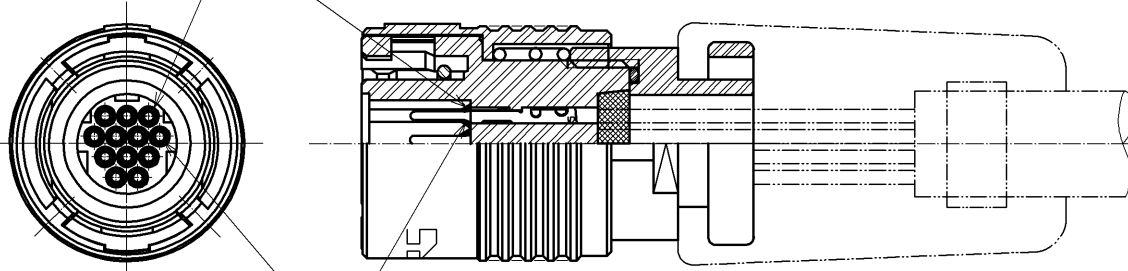

1.Scope  
This document provides instruction for wiring HR30 overmold type connector.  
2.Procedure step

No.	Procedure step								
1	<p>Strip the cable jacket.</p>  <p style="text-align: center;">table 1</p> <table border="1" data-bbox="858 660 1284 801"> <tr> <td></td> <td>A</td> </tr> <tr> <td>Solder type:3 and 6 pos.</td> <td>20mm max</td> </tr> <tr> <td>Solder type:12 pos.</td> <td>25mm max</td> </tr> <tr> <td>Crimp type:10 and 12 pos.</td> <td>30~35mm</td> </tr> </table>		A	Solder type:3 and 6 pos.	20mm max	Solder type:12 pos.	25mm max	Crimp type:10 and 12 pos.	30~35mm
	A								
Solder type:3 and 6 pos.	20mm max								
Solder type:12 pos.	25mm max								
Crimp type:10 and 12 pos.	30~35mm								
2	<p>Insert the spacer to the cable.</p> 								
3	<p>◆Solder type Insert the P-Housing in the applicable solder termination fixture. Solder the wires to the contacts of the P-Housing.</p>  <p style="text-align: center;">table 2</p> <table border="1" data-bbox="1021 1680 1353 1803"> <tr> <td></td> <td>B</td> </tr> <tr> <td>Shell size : 6</td> <td>8</td> </tr> <tr> <td>Shell size : 7,8</td> <td>11</td> </tr> </table>		B	Shell size : 6	8	Shell size : 7,8	11		
	B								
Shell size : 6	8								
Shell size : 7,8	11								

COUNT	DESCRIPTION OF REVISIONS	DESIGNED	CHECKED	DATE												
△																
<p>名称 TITLE Assembly procedure for HR30 overmold type connectors.</p>			<p><b>HRS</b> ヒロセ電機株式会社 HIROSE ELECTRIC CO., LTD.</p> <table border="1"> <tr> <td>APPROVED</td> <td>MO. SATOH</td> <td>09.08.27</td> </tr> <tr> <td>CHECKED</td> <td>HY. KISHI</td> <td>09.08.27</td> </tr> <tr> <td>CHARGED</td> <td>TY. SUZUKI</td> <td>09.08.27</td> </tr> <tr> <td>WRITTEN</td> <td>TY. SUZUKI</td> <td>09.08.27</td> </tr> </table>		APPROVED	MO. SATOH	09.08.27	CHECKED	HY. KISHI	09.08.27	CHARGED	TY. SUZUKI	09.08.27	WRITTEN	TY. SUZUKI	09.08.27
APPROVED	MO. SATOH	09.08.27														
CHECKED	HY. KISHI	09.08.27														
CHARGED	TY. SUZUKI	09.08.27														
WRITTEN	TY. SUZUKI	09.08.27														
<p>技術指定書 TECHNICAL SPECIFICATION</p>			<p>ETAD-C0198</p>	<p>△ 1 / 3</p>												

No.	Procedure step												
3	<p>◆Crimp type                      Insert the crimped insulated wires into the terminal. (Crimp type)                      Note) C/H shown in table 3.</p>  <p style="text-align: center;">table 3</p> <table border="1" data-bbox="609 840 1109 1153"> <thead> <tr> <th>AWG SIZE</th> <th>Contact wire crimp height(mm)</th> <th>Covering crimp height(mm)</th> </tr> </thead> <tbody> <tr> <td>UL1571 Stranded wire AWG26</td> <td>0.52 ~ 0.58</td> <td>0.85 ~ 1.00</td> </tr> <tr> <td>UL1571 Stranded wire AWG28</td> <td>0.48 ~ 0.54</td> <td>0.85 ~ 1.00</td> </tr> <tr> <td>UL1571 Stranded wire AWG 30</td> <td>0.46 ~ 0.52</td> <td>0.80 ~ 0.95</td> </tr> </tbody> </table>	AWG SIZE	Contact wire crimp height(mm)	Covering crimp height(mm)	UL1571 Stranded wire AWG26	0.52 ~ 0.58	0.85 ~ 1.00	UL1571 Stranded wire AWG28	0.48 ~ 0.54	0.85 ~ 1.00	UL1571 Stranded wire AWG 30	0.46 ~ 0.52	0.80 ~ 0.95
AWG SIZE	Contact wire crimp height(mm)	Covering crimp height(mm)											
UL1571 Stranded wire AWG26	0.52 ~ 0.58	0.85 ~ 1.00											
UL1571 Stranded wire AWG28	0.48 ~ 0.54	0.85 ~ 1.00											
UL1571 Stranded wire AWG 30	0.46 ~ 0.52	0.80 ~ 0.95											
4	<p>Potting silicone into P-Housing.</p> 												

No.	Procedure step
01	<p>Assemble Spacer to the P-Housing.</p> <p>( The recommended clamp torque of spacer to be 0.5 N·m. Loctite 271, Locprimer 7649, Henkel Japan is recommended to prevent spacer from loosening. )</p> 
01	<p>Overmolding</p> <p>Please start overmolding after silicone has congealed.</p>  <p>The use of the clamp fitting is recommended.</p>
7	<p>After overmolding.</p> <p>Please check whether silicone and overmold has exceeded to edge of contact hole which is mating point side.</p> <p>Here is sample which may caused electric problem.</p>  <p>Silicone and overmold. (Even if one of exceeding of overmold or silicone, it may cause electric problem.)</p>