

DO NOT SCALE DRAWING
DIMENSION IN METRIC

PROJECT NO. SIMILAR ITEM DWG. NO. SD-35028-*****

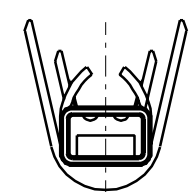
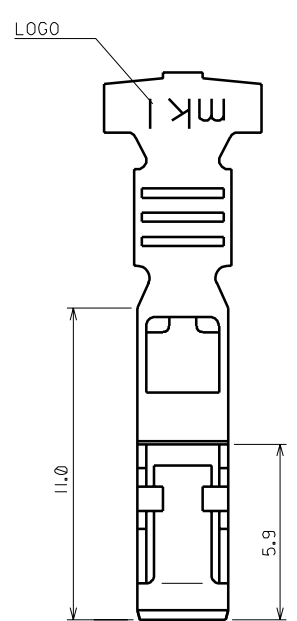
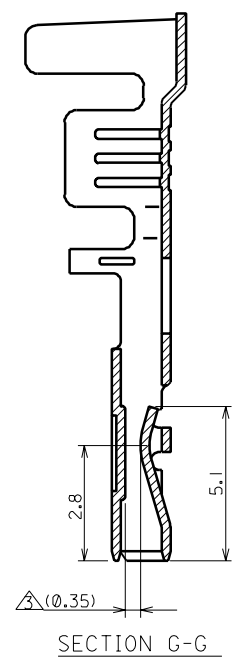
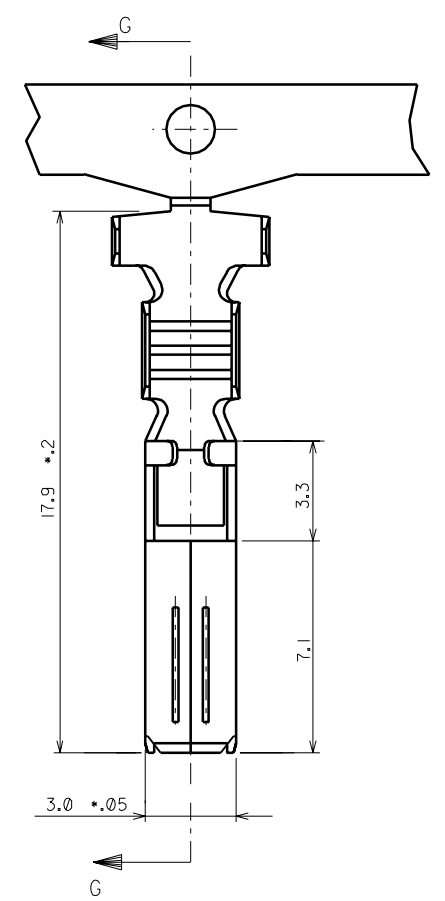
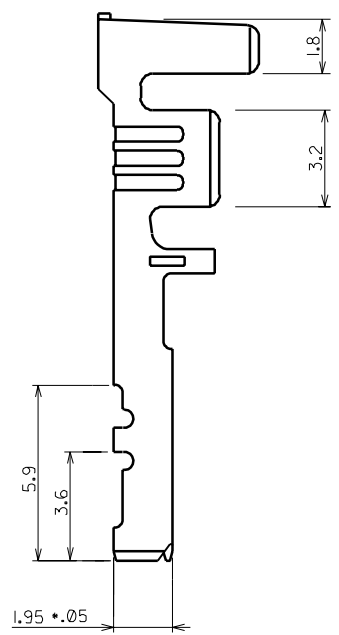

NOTES

- MATERIAL: PHOSPHOR BRONZE
THICKNESS : 0.30 ± 0.02
WIDTH : 22.8 ± 0.08
- PLATING: PREPLATING (REFLOW TREATMENT)
- MALE TAB (THICK 0.6 ± 0.05) FIT.
-INSERTION FORCE: 0.8kgf. MAX.
-RETENTION FORCE: 0.3kgf. MIN.
- WIRE SIZE : AWG #20 × 2 35028-9502
AWG #18 ± #22 35028-9010
AWG #14 ± #20 35028-1111

REVISED EC NO. KOR2002-0074 DRWN: C.B.CHIN 02/02/19 CHK: W.Y.YANG APPR: C.W.LEE	DESCRIPTION	QUALITY SYMBOLS	GENERAL TOLERANCES: (UNLESS SPECIFIED)	SCALE 6:1	DESIGN UNITS <input checked="" type="checkbox"/> mm <input type="checkbox"/> INCH	THIRD ANGLE PROJECTION	DIMENSIONS: <input type="checkbox"/> mm <input type="checkbox"/> INCH <input checked="" type="checkbox"/> mm ONLY	SHT	REV
		MAJOR = 0	CRITICAL = 0	4 PLACES ±0. ±.	3 PLACES ±0. ±.	2 PLACES ±0.15 ±.	1 PLACE ±0.15 ±.	DRAWN BY & DATE H.J.KIM 94/06/25	
H	REV	ANGULAR: ± 0.5°		CAD FILENAME S35028.DGN		TITLE: .070 FEMALE TERMINAL		MATERIAL NO. SEE NOTES	
		DRAFT WHERE APPLICABLE MUST REMAIN WITHIN DIMENSIONS		THIS DRAWING CONTAINS INFORMATION THAT IS PROPRIETARY TO MOLEX INCORPORATED AND SHOULD NOT BE USED WITHOUT WRITTEN PERMISSION.		DRAWING NO. SD-35028-****		SHEET NO. IOF 1	

MOLEX MOLEX INCORPORATED