

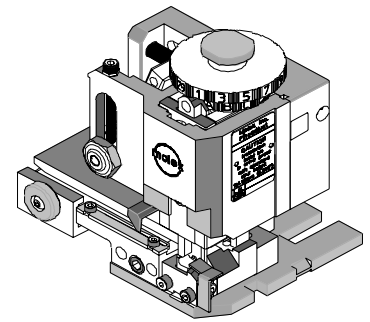

FineAdjust Applicator Specification Sheet Part No. 63865-3000



FEATURES

- Quick punch removal with the push of a button for fast and easy tooling change
- Applicator designed to industry standard mounting and shut height 135.80mm (5.346")
- Quick set-up time; plus the crimp height, track and feed adjustments can be set without removing the applicator from the press
- Fine adjustment allows users to achieve target with little effort by adjusting in increments of 0.15mm (.0006") for conductor crimp height and .063mm (.0025") for insulation height
- Independent adjustment rings allow users to quickly adjust the conductor or insulation crimp height without affecting each other
- Directly adapts to most automatic wire processing machines

SCOPE

Terminal Series No.		Wire Size		Insulation Diameter		Strip Length	
		AWG	mm ²	mm	In.	mm	In.
33000-1001	Male (Tin)	14	2.00	2.54-2.69	.100-.106	4.70-5.60	.185-.220
33011-0002	Male (Gold)	14	2.00	2.54-2.69	.100-.106	4.70-5.60	.185-.220

Terminal will accommodate the following wire specification:
Wires to be thin wall thickness per Ford specification MIL135-A1 and MIL123-A

DEFINITION OF TERMS

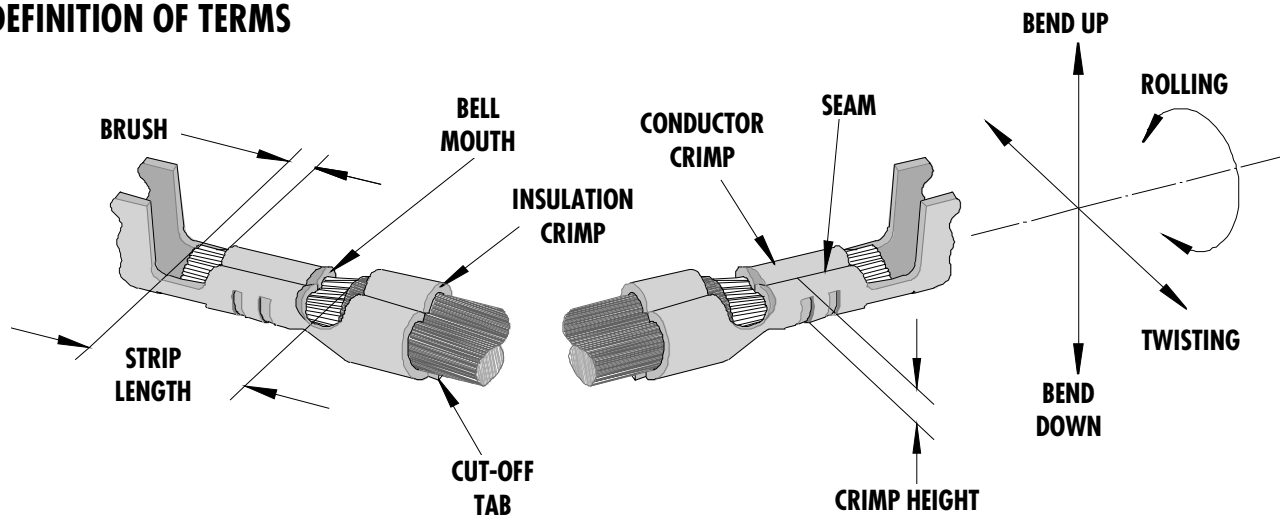

The above terminal drawing is a generic terminal representation. It is not an image of a terminal listed in the scope.

CRIMP SPECIFICATION

Terminal Series No.	Bell mouth		Cut-off Tab Max.		Conductor Brush	
	mm	In.	mm	In.	mm	In.
33000-1001	0.25-1.25	.010-.049	0.50	.020	0.15-0.65	.006-.026
33011-0002	0.25-1.25	.010-.049	0.50	.020	0.15-0.65	.006-.026

Terminal Series No.	Bend up	Bend down	Twist	Roll	Punch Width mm (Ref)				Seam Seam shall not be open and no wire allowed out of the crimping area
	Degree		Degree		Conductor		Insulation		
					mm	In	mm	In	
33000-1001	3	3	3	5	2.35	.093	2.75	.108	
33011-0002	3	3	3	5	2.35	.093	2.75	.108	

After crimping, the conductor profile should measure the following.

Terminal Series No.	Wire Size		Conductor Crimp Height		Insulation Crimp Height		Pull Force Min.	
	AWG	mm ²	mm	In.	Mm (Ref)	In. (Ref)	N	Lb.
33000-1001	14	2.00	1.60-1.70	.063-.067	2.70-2.90	.106-.114	180.0	40.50
33011-0002	14	2.00	1.60-1.70	.063-.067	2.70-2.90	.106-.114	180.0	40.50

Pull Force should be measured with no influence from the insulation crimp.

The above specifications are guidelines to an optimum crimp.

PARTS LIST

Item	Order No	Engineering No.	Description	Quantity
	63865-3000	63865-3000	FineAdjust Applicator (Fig. 1)	REF
1	63457-0004	63457-0004	Conductor Punch	1 Y
2	63455-0007	63455-0007	Conductor Anvil	1 Y
3	63454-0010	63454-0010	Insulation Punch	1 Y
4	63456-0009	63456-0009	Insulation Anvil	1 Y
5	63461-0001	63461-0001	Cut-Off Plunger	1 Y
6	63443-0036	63443-0036	Front Plunger Retainer	1 Y
7	63700-0539	63700-0539	Cut-Off Plunger Spring	1
8	63443-3160	63443-3160	Front Plunger Striker	1
9	63443-0021	63443-0021	Lower Tooling Key	1
10	63443-6013	63443-6013	Rear Cover	1
11	11-18-4094	60709A111	Front Cover	1
12	63443-2506	63443-2506	Anvil Mount	1
13	11-18-4080	60707-5	Wire Stop	1
14	63443-0009	63443-0009	Scrap Chute	1
15	63801-3100	63801-3100	Wide Track FineAdjust	1
16	63459-0001	63459-0001	*Wide Terminal Track (Modified)	1
17	N/A	N/A	M3 by 6Lg. SHCS	2**
18	N/A	N/A	M4 by 6Lg. SHCS	1**
19	N/A	N/A	M4 by 12Lg. BHCS	2**
20	N/A	N/A	M4 by 50Lg. SHCS	2**
21	N/A	N/A	M5 by 12Lg SHCS	1**
22	N/A	N/A	3MM by 6Lg. Roll Pin	1**
23	N/A	N/A	#10-32 by 1/4"Lg. BHCS	1**
	63865-3070	63865-3070	Tool Kit (All Y Items)	REF

* Frame Part - To be modified

** The following purchased parts are available from an Industrial supply company such as MSC (1-800-645-7270).

Assembly Drawing

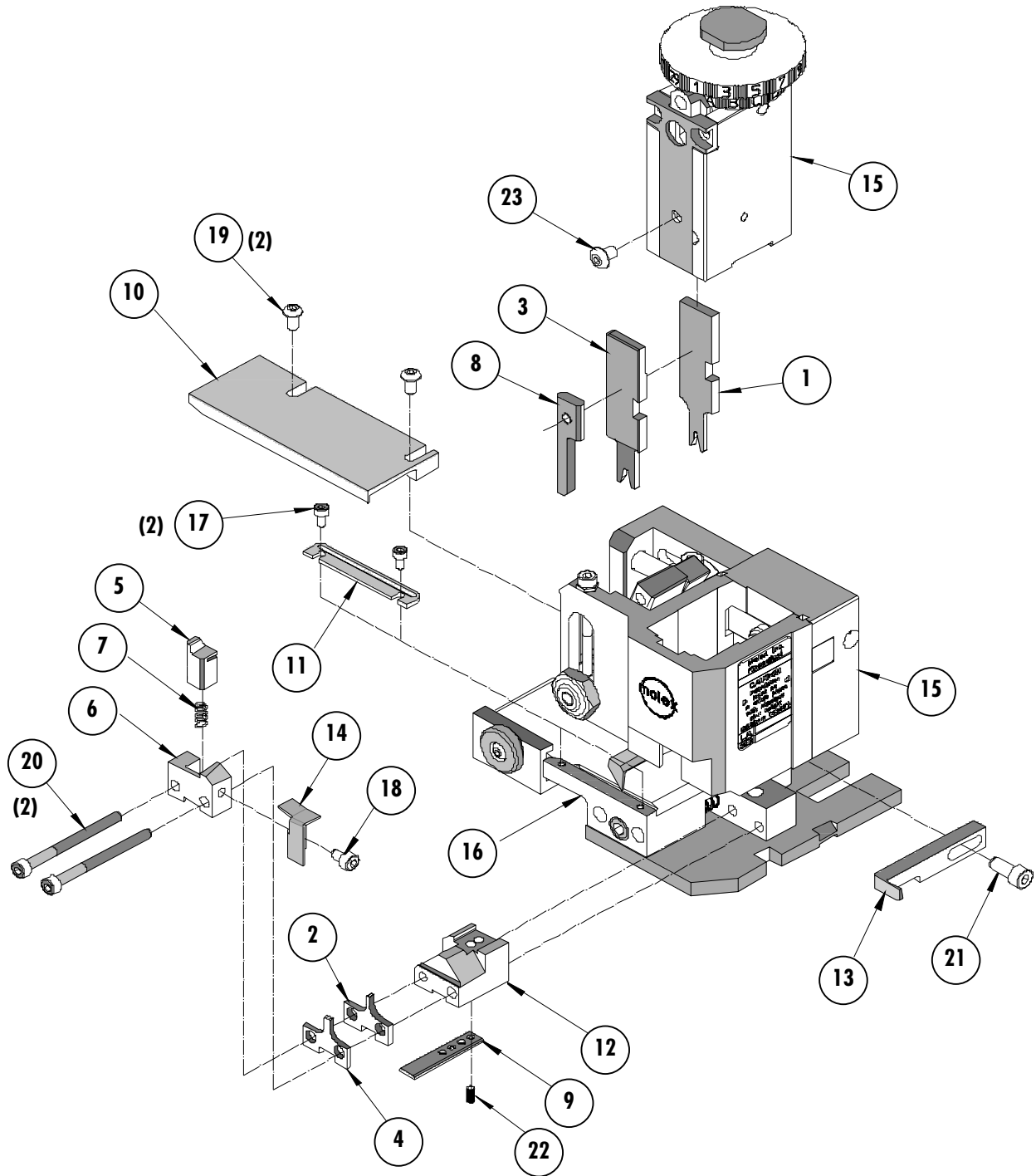

Figure 1

NOTES

1. Molex recommends an extra perishable tooling kit be maintained at your facility.
2. Verify tooling alignment by manually cycling the press and Applicator before crimping under power. Check that all screws are tight.
3. Slugs, Terminals, Dirt and Oil should be kept clear of work area.
4. Wear safety glasses at all times.
5. For recommended maintenance refer to the FineAdjust Manual.

CAUTION: This applicator should only be used in a press with a shut height of 135.8 mm (5.346"). Tooling damage could result at a lower setting.

CAUTION: To prevent injury never operate this Applicator without the guards supplied with the press or wire-processing machine in place. Reference the press or wire processing manufacturer's instruction manual.

CAUTION: Molex crimp specifications are valid only when used with Molex terminals, applicators and tooling.

Molex Application Tooling Group

1150 E. Diehl Road
Naperville, IL 60563
Tel: (630) 969-4550
Fax: (630) 505-0049

Visit our Web site at <http://www.molex.com>