

RECOMMEND P.C.B. LAYOUT

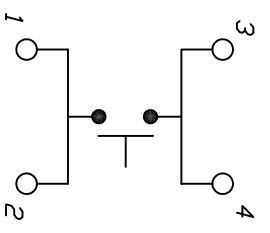

CIRCUIT: SPST
CONTACT CONFIGURATION

- NOTES:
1. ALL DIMENSIONS IN MM
 2. GENERAL TOLERANCE: X.X=±0.4, X.XX=±0.25
 3. TERM. NOS. FOR REF. ONLY
 4. RATING: 50mA, @12VDC
 5. TRAVEL: 0.30±0.15mm
 6. OPERATING FORCE: 160±50gf
 7. CONTACT RESISTANCE: 100 MILLI-OHMS MAX
 8. ELECTRICAL LIFE: 100,000 CYCLES MIN

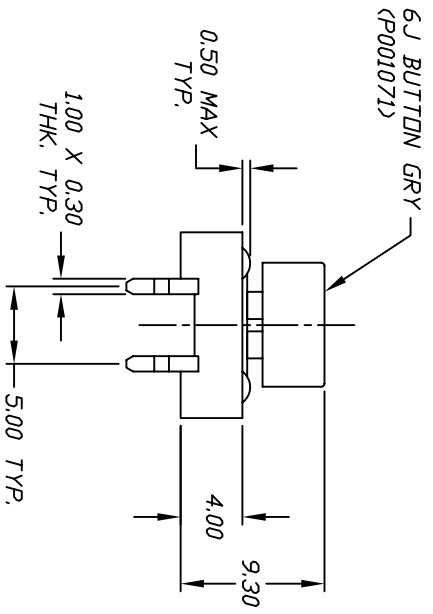

REV.	ECN No.	DESCRIPTION	DATE	CHKD
A	11093	RELEASED FOR PRODUCTION	12/07/00	PML

TITLE	SCALE	DATE	DR	DWG	REV
TL 1100 F160 Q/6J GRY	2:1	12/07/00	PML	XP0174P	A

THE INFORMATION CONTAINED IN THIS DOCUMENT IS PROPRIETARY TO E-SWITCH AND IS NOT TO BE COPIED OR TRANSFERRED