

LOC	DIST	REVISIONS			
P	LTR	DESCRIPTION	DATE	DWN	APVD
DW	/	B4	REVISED. (ECR-15-011655)	17AUG15	S.C. H.L.

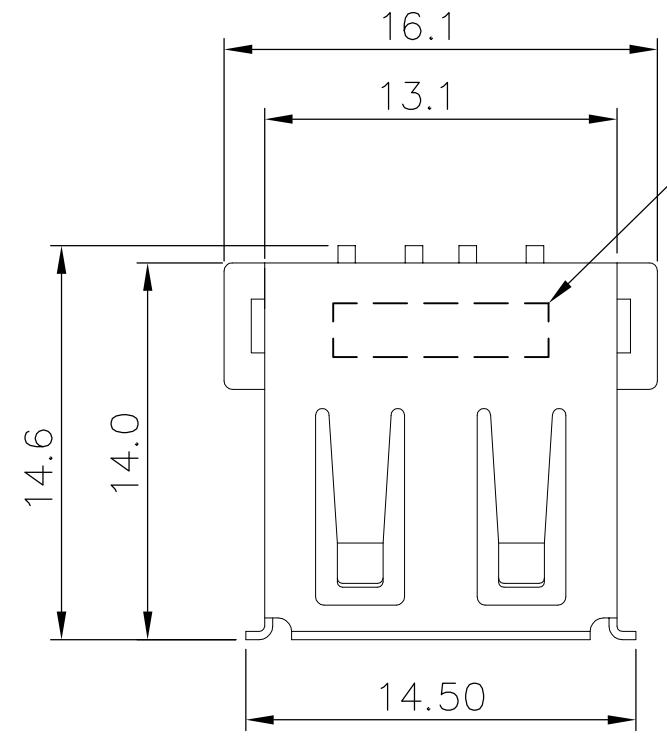

LOGO &
DATE CODE

- NOTES:
- MATERIAL:
HOUSING: THERMOPLASTIC WITH 30% GF, UL 94V-0,
COLOR: (SEE TABLE).
CONTACTS: PHOSPHOR BRONZE, THICKNESS=0.25mm..
SHIELD: BRASS, THICKNESS=0.30mm.
 - FINISH:
CONTACT: 0.762µm [30µ"] MIN. GOLD PLATED ON CONTACT AREA.
3.048µm [120µ"] MIN. BRIGHT-TIN ON SOLDER TAIL, WITH
ENTIRE CONTACT UNDERPLATED 1.27µm [50µ"] MIN. NICKEL.
SHIELD: 0.762µm [30µ"] MIN. NICKEL OVER 0.762µm [30µ"] MIN.
 - REFLOW SOLDER CAPABLE TO 260°C PER TE TEST SPEC.
109-201, CONDITION B.

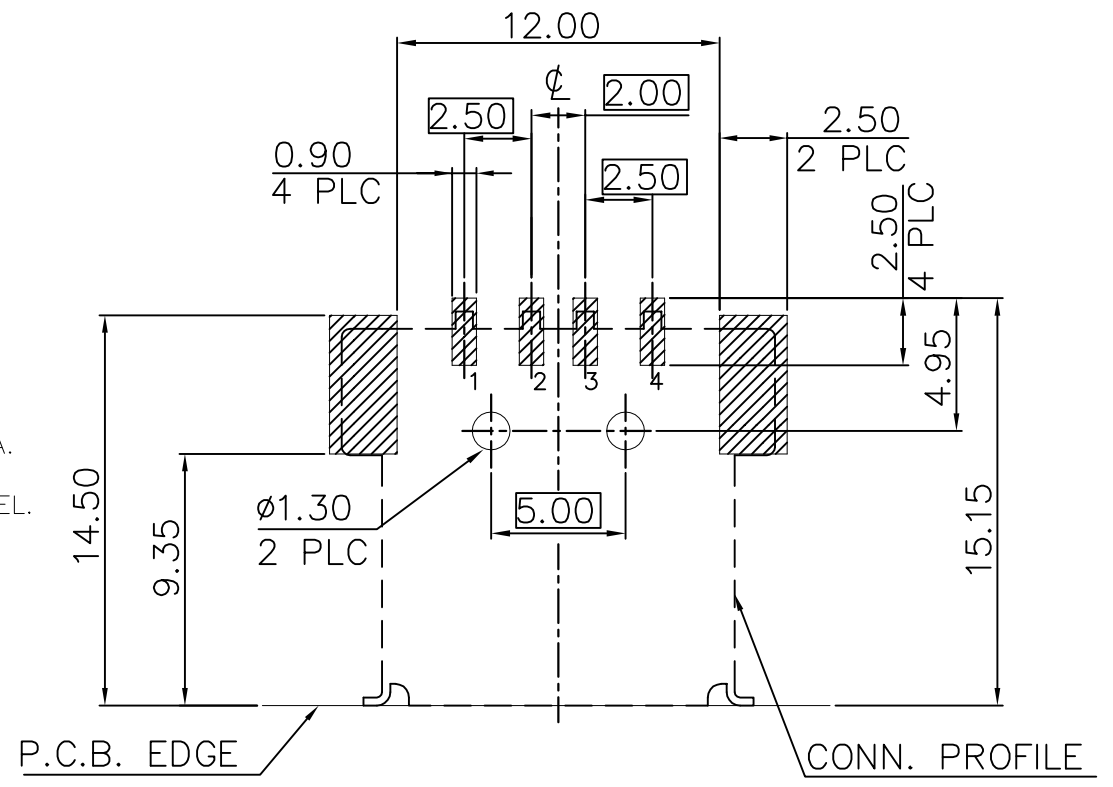

RECOMMENDED P.C.B. LAYOUT (THICKNESS=1.6mm)
(TOP VIEW) TOLERANCES: ±0.05

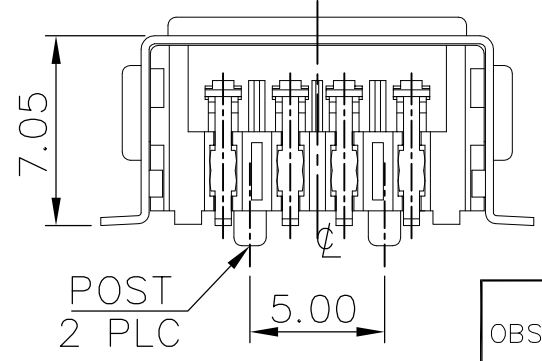
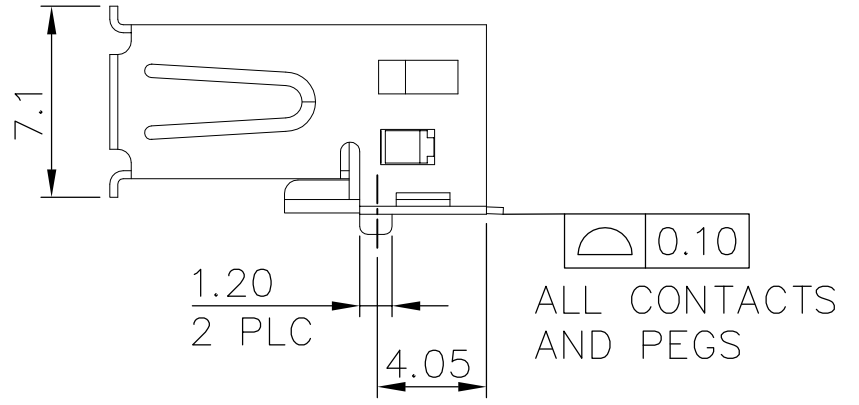
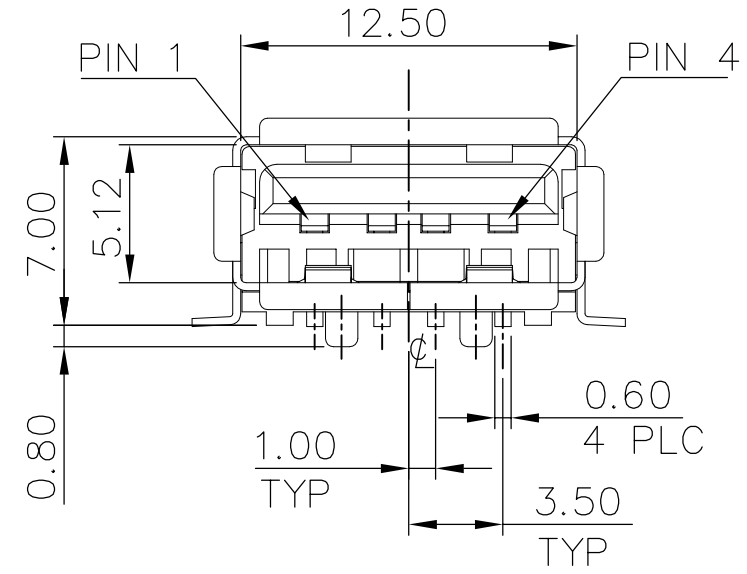

OBSOLETE	W/	BLACK	1-1734082-2
		WHITE	1-1734082-1
OBSOLETE	W/O	BLACK	1734082-2
OBSOLETE		WHITE	1734082-1
	POST	COLOR	PART NUMBER

THIS DRAWING IS A CONTROLLED DOCUMENT.		DWN	O. HU	20OCT2005	TE Connectivity
DIMENSIONS: MM		CHK	S. HSU	20OCT2005	
		APVD	W.J. KE	20OCT2005	
TOLERANCES UNLESS OTHERWISE SPECIFIED:		PRODUCT SPEC		NAME	
0 PLC ± - 1 PLC ± 0.35 2 PLC ± 0.25 3 PLC ± 0.15 4 PLC ± - ANGLES ± 3°		APPLICATION SPEC		108-57505	
MATERIAL		WEIGHT		SIZE	
SEE NOTE		1.82 GRAMS		A300779 C=1734082	
FINISH		CUSTOMER DRAWING		RESTRICTED TO	
SEE NOTE				SCALE	
				SHEET 1 OF 4	
				REV B4	

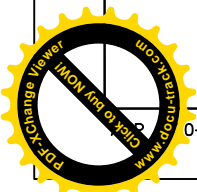

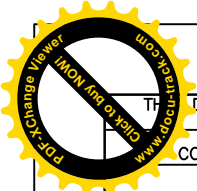

LOC	DIST	REVISIONS			
P	LTR	DESCRIPTION	DATE	DWN	APVD
		SEE SHEET 1.			

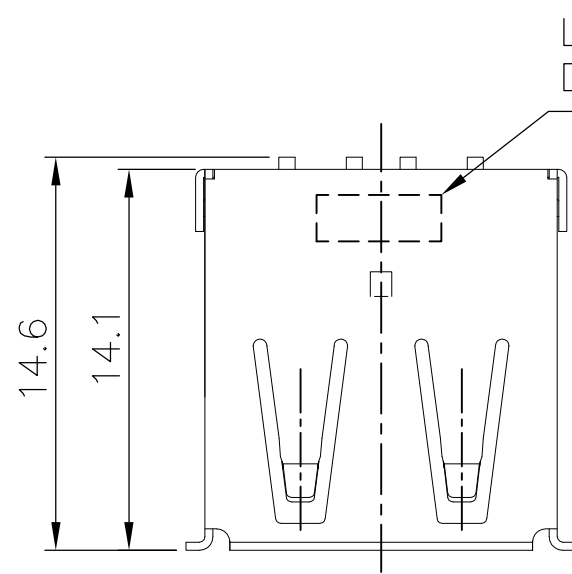

- NOTES:
- MATERIAL:
 HOUSING: THERMOPLASTIC WITH 30% GF, UL 94V-0, COLOR: BLACK.
 CONTACTS: PHOSPHOR BRONZE, THICKNESS=0.25mm.
 SHIELD: BRASS, THICKNESS=0.30mm.
 - FINISH:
 CONTACT: 0.762μm [30μ"] MIN. GOLD PLATED ON CONTACT AREA.
 3.048μm [120μ"] MIN. BRIGHT-TIN ON SOLDER TAIL, WITH ENTIRE CONTACT UNDERPLATED 1.27μm [50μ"] MIN. NICKEL.
 SHIELD: 0.762μm [30μ"] MIN. NICKEL OVER 0.762μm [30μ"] MIN.
 - REFLOW SOLDER CAPABLE TO 260°C PER TE TEST SPEC. 109-201, CONDITION B.

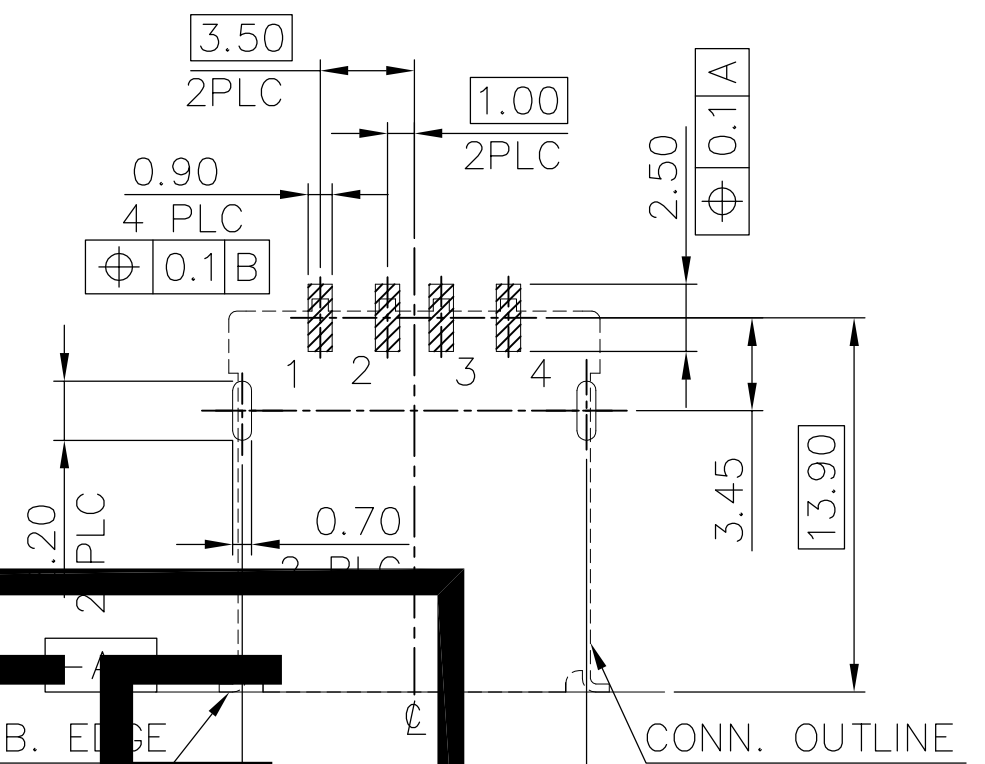

OBSOLETE

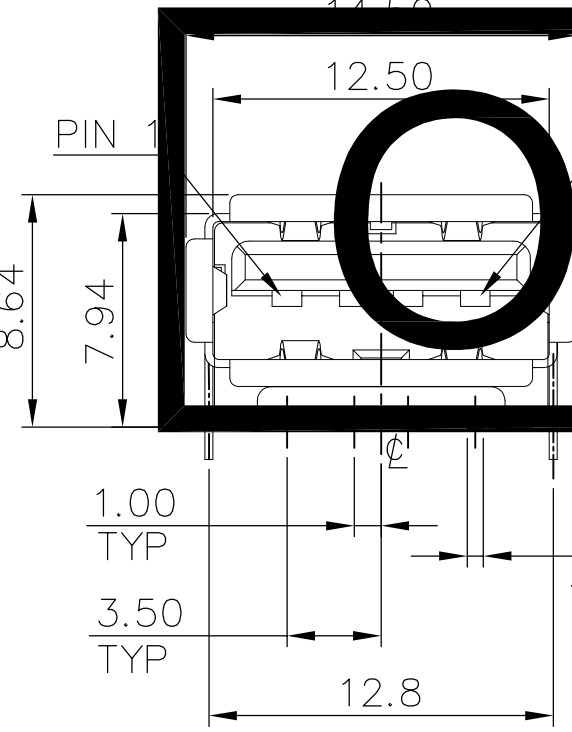

RECOMMEND P.C.B LAYOUT (THICKNESS=1.6mm)
 (COMPONENT SIDE) TOLERANCE ±0.05

ALL CONTACTS AND PEGS

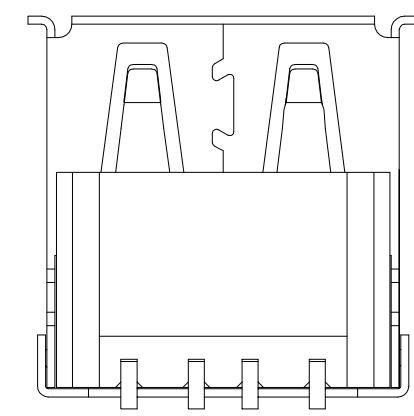

2-1734082-1
 PART NUMBER

THIS DRAWING IS A CONTROLLED DOCUMENT.		DWN	TE Connectivity	
DIMENSIONS: MM		CHK		
TOLERANCES UNLESS OTHERWISE SPECIFIED: 0 PLC ± - 1 PLC ± 0.35 2 PLC ± 0.25 3 PLC ± 0.15 4 PLC ± - ANGLES ± 3°		APVD	NAME	
MATERIAL		PRODUCT SPEC	USB CON, RCPT, ASS'Y, R/A SMT, A TYPE	
SEE NOTE	FINISH	APPLICATION SPEC	SIZE	RESTRICTED TO
SEE NOTE	SEE NOTE	WEIGHT	A300779	
		CUSTOMER DRAWING	C=1734082	
		SCALE	DRAWING NO	
		SHEET	2 OF 4	REV B4

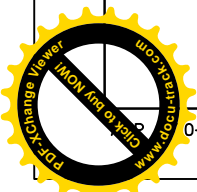

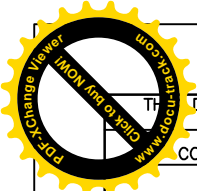

4

3

2

1

DRAWING IS UNPUBLISHED. RELEASED FOR PUBLICATION AUG 2006
 COPYRIGHT 2009 BY TYCO ELECTRONICS CORPORATION. ALL RIGHTS RESERVED.

LOC	DIST	REVISIONS			
P	LTR	DESCRIPTION	DATE	DWN	APVD
		SEE SHEET 1.			

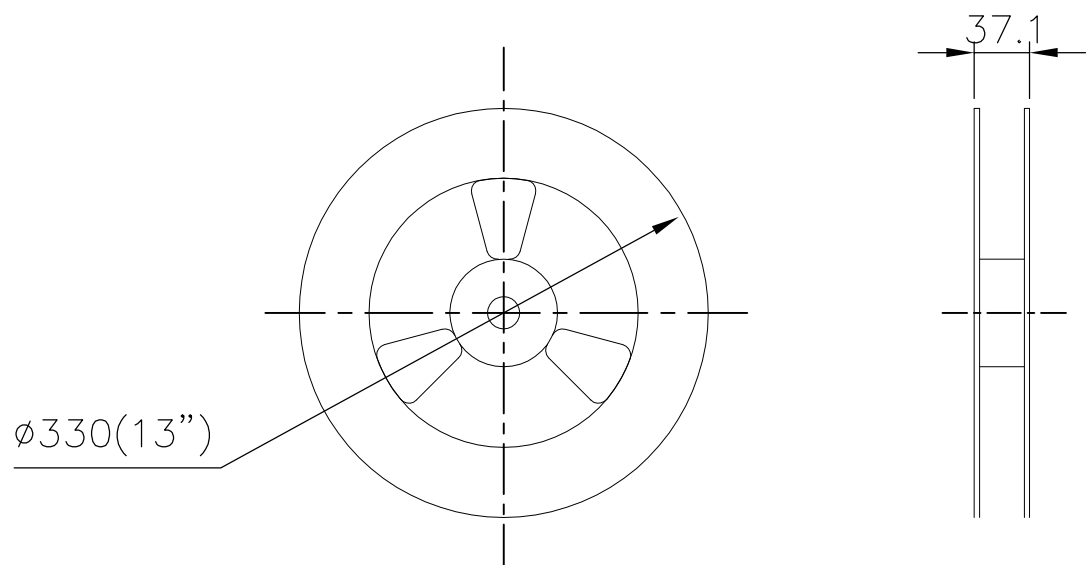
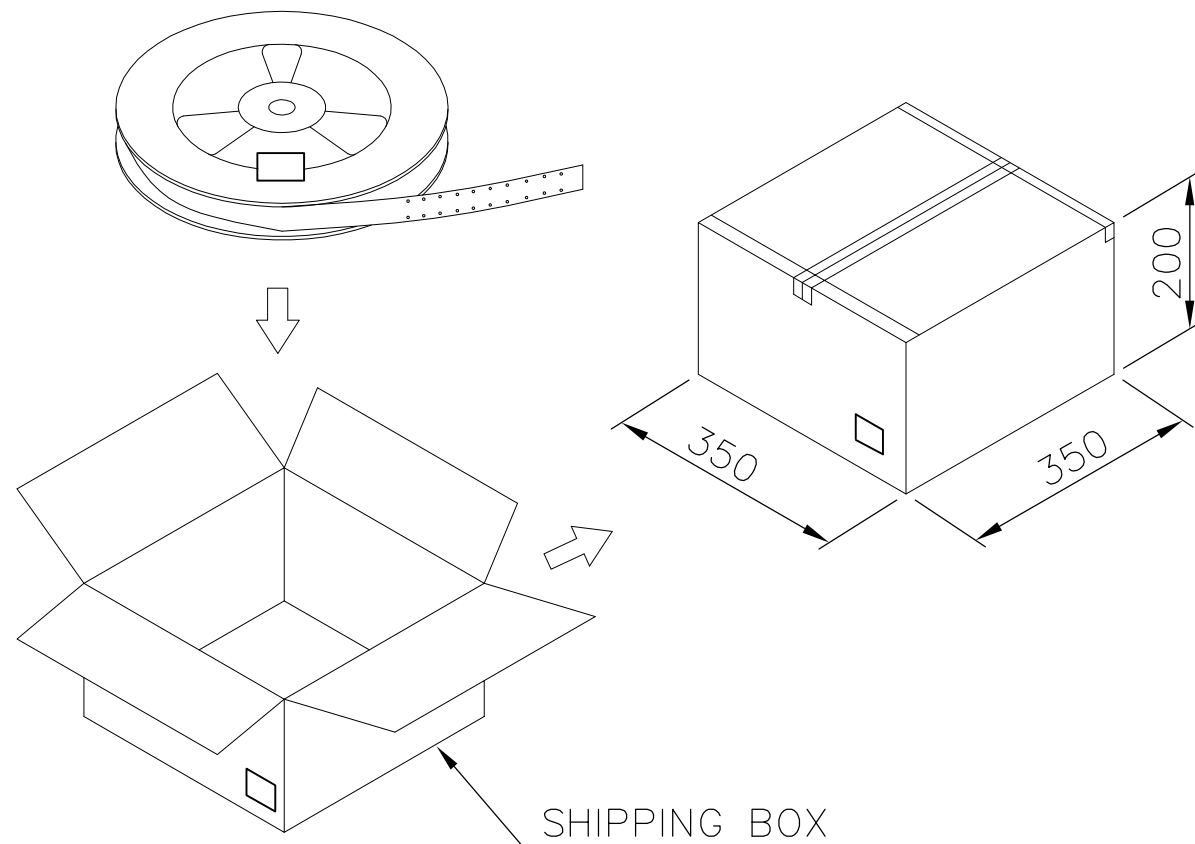
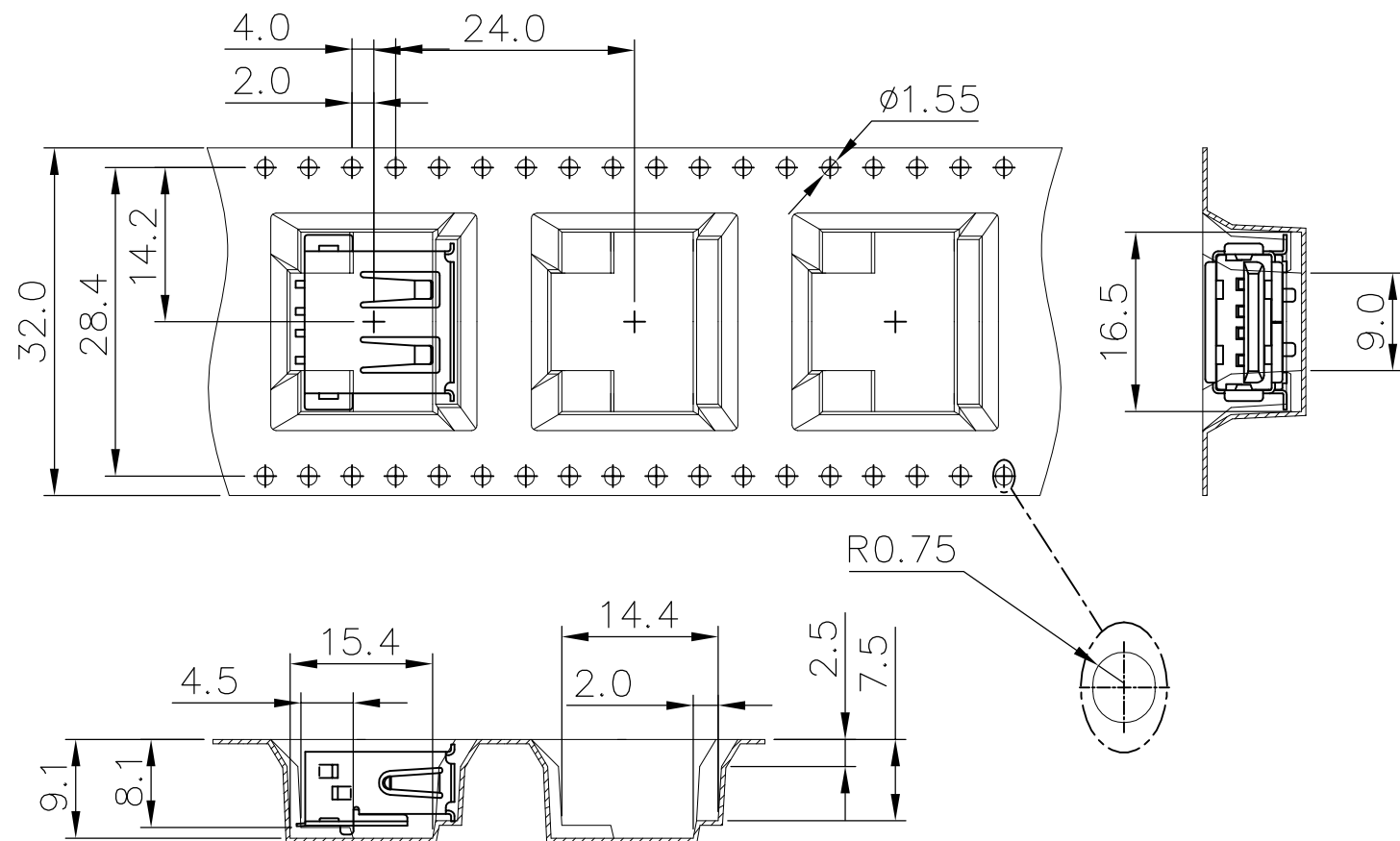
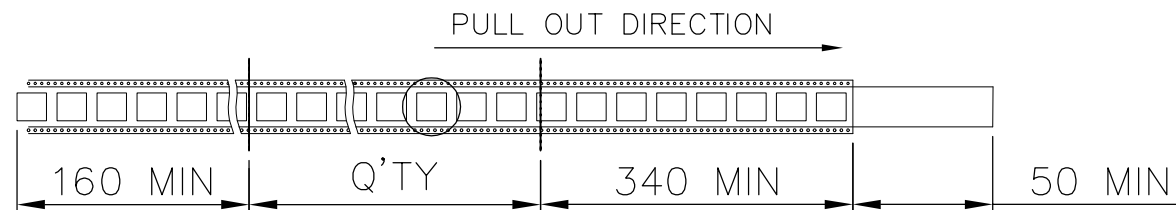

300	5	1500	5.36	2.73	1-1734082-2
					1-1734082-1
					1734082-2
					1734082-1
PCS/REEL	REELS/BOX	QUANTITY (PCS)	G/W (Kg)	N/W (Kg)	PART NUMBER

THIS DRAWING IS A CONTROLLED DOCUMENT.		DWN	STE TE Connectivity		
DIMENSIONS: MM		CHK			
TOLERANCES UNLESS OTHERWISE SPECIFIED:		APVD	NAME		
0 PLC ± -		PRODUCT SPEC	USB CON, RCPT, ASS'Y, R/A SMT, A TYPE		
1 PLC ± -		APPLICATION SPEC	SIZE	CAGE CODE	DRAWING NO
2 PLC ± -		WEIGHT	A300779	C=1734082	RESTRICTED TO
3 PLC ± -		CUSTOMER DRAWING	SCALE		SHEET 3 OF 4
4 PLC ± -					REV B4
ANGLES ± -					
FINISH					
MATERIAL					

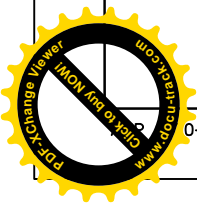

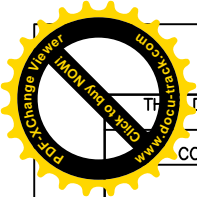

LOC	DIST	REVISIONS			
P	LTR	DESCRIPTION	DATE	DWN	APVD
		SEE SHEET 1.			

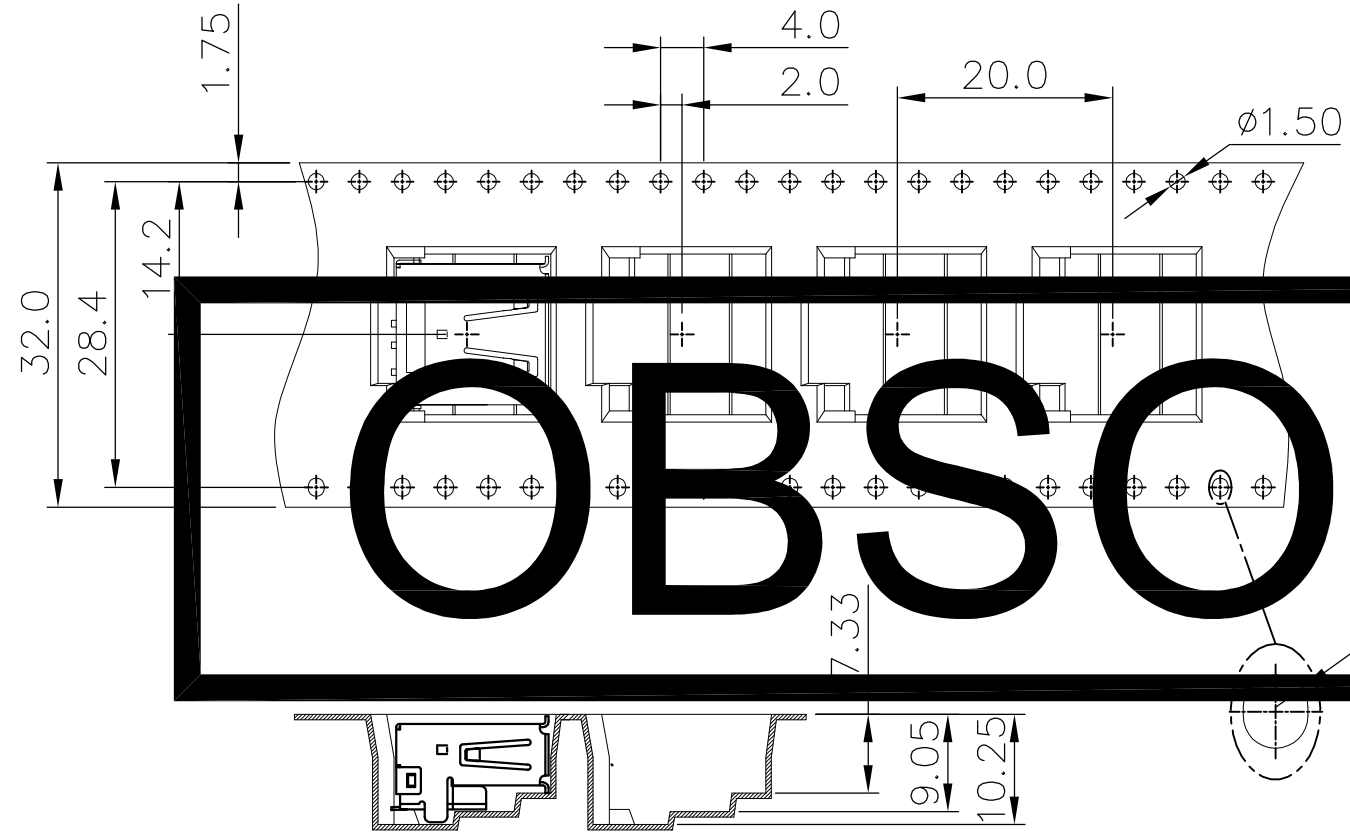
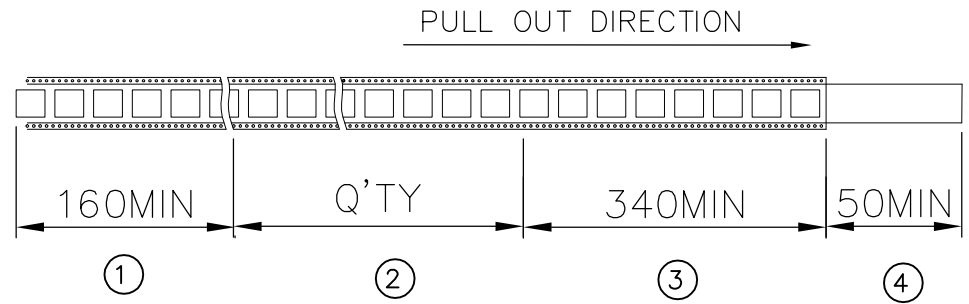

OBSOLETE

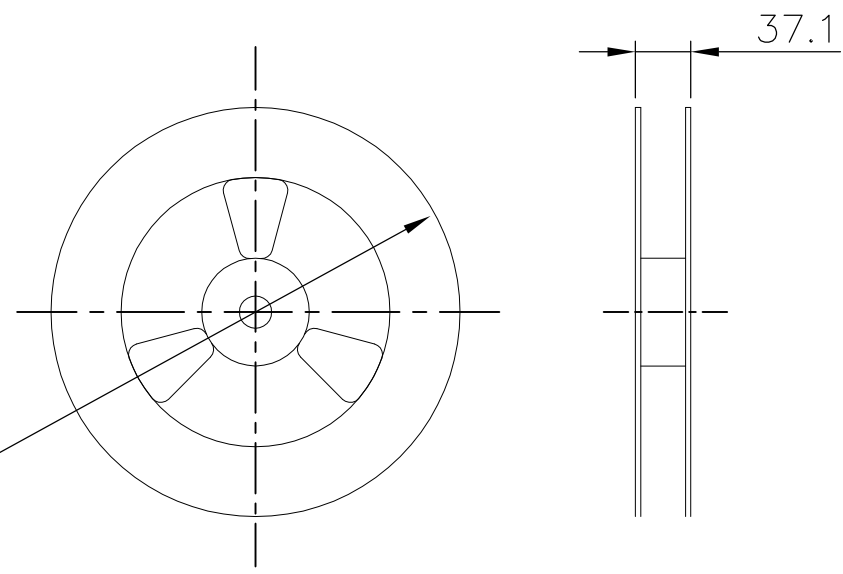
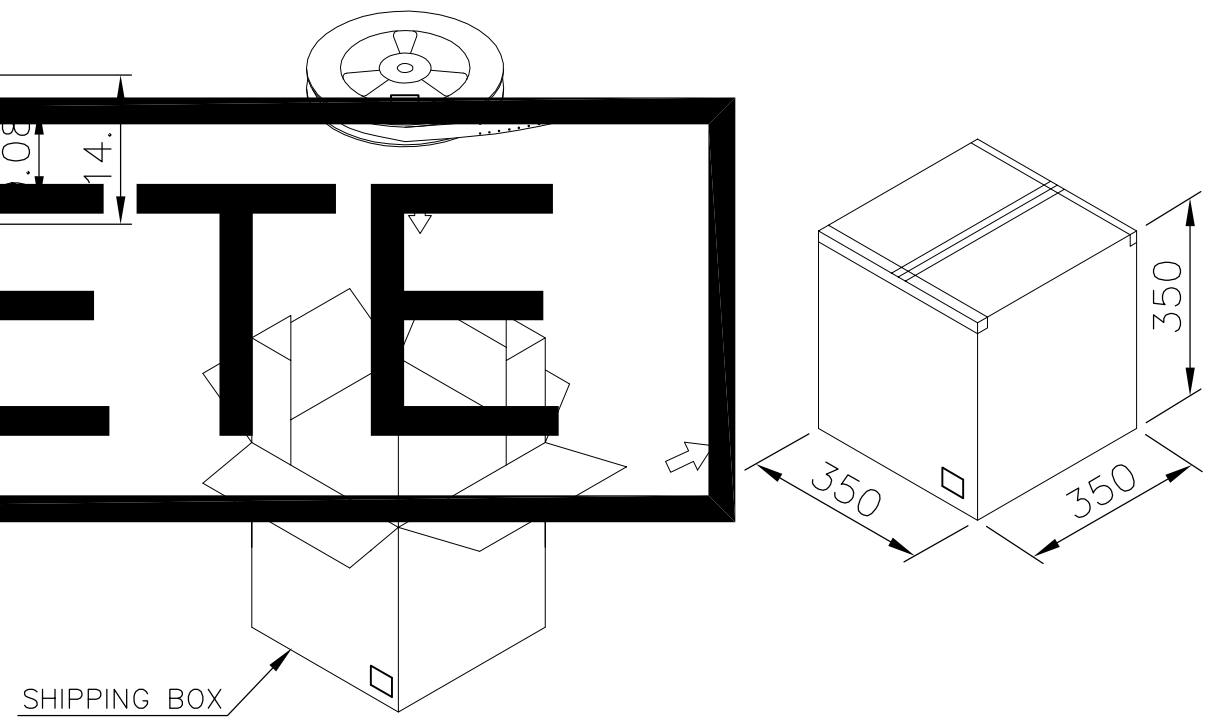

300	9	2700	12	5.94	1734082
PCS/REEL	REELS/CARTON	QUANTITY (PCS)	G/W (Kg)	N/W (Kg)	PART NUMBER

THIS DRAWING IS A CONTROLLED DOCUMENT.		DWN	TE TE Connectivity		
DIMENSIONS: MM		CHK			
TOLERANCES UNLESS OTHERWISE SPECIFIED:		APVD	NAME		
0 PLC ± -		PRODUCT SPEC	USB CON, RCPT, ASS'Y, R/A SMT, A TYPE		
1 PLC ± -		APPLICATION SPEC	SIZE	CAGE CODE	DRAWING NO
2 PLC ± -		WEIGHT	A300779	C=1734082	RESTRICTED TO
3 PLC ± -		CUSTOMER DRAWING	SCALE		SHEET 4 OF 4
4 PLC ± -					REV B4
ANGLES ± -					
FINISH					
MATERIAL					

