

- NOTES:
- MATERIAL:
HOUSING: THERMOPLASTIC, GLASS-FILLED UL-94V-0, BLACK
TERMINAL: COPPER ALLOY
SMT NAIL: COPPER ALLOY
 - PLATING:
CONTACT: 0.38µm MIN. SELECTIVE GOLD OVER 1.27µm MIN. NICKEL UNDERPLATE.
SOLDERTAIL: 2.54µm MIN. TIN OVER 1.27µm MIN. NICKEL UNDERPLATE.
SMT NAIL: 2.54µm MIN. TIN OVER 1.27µm MIN. NICKEL UNDERPLATE.
 - MOLEX LOGO LOCATED APPROXIMATELY AT SHOWN.
 - NON FUNCTIONAL CORE HOLES ARE SUBJECTED TO CHANGE WITHOUT NOTICE.
 - MATES WITH IVDR PLUG SERIES 78158.
 - BLISTERING ON CAP IS ACCEPTABLE.

RELEASE EC NO: S2008-0173 DRWNS: SCHEONG CHKD: CGOH APPR: KCL ING 2007/09/21 2007/09/25 2007/09/25	QUALITY SYMBOLS ▽=0 ▽=0	GENERAL TOLERANCES (UNLESS SPECIFIED)		DIMENSION STYLE MM ONLY		SCALE NTS	DESIGN UNITS METRIC	THIRD ANGLE PROJECTION		
				DRAWN BY SCHEONG		DATE 2007/08/31	TITLE 1.27MM PITCH, 26 CKTS R/A, SMT IVDR RECEPTACLE			
				CHECKED BY CGOH		DATE 2007/09/17				
				APPROVED BY KCL ING		DATE 2007/09/18	MOLEX INCORPORATED DOCUMENT NO. SD-78159-001 SHEET NO. 1 OF 4			
A	REV	DRAFT WHERE APPLICABLE MUST REMAIN WITHIN DIMENSIONS		SIZE A3		THIS DRAWING CONTAINS INFORMATION THAT IS PROPRIETARY TO MOLEX INCORPORATED AND SHOULD NOT BE USED WITHOUT WRITTEN PERMISSION				

10 9 8 7 6 5 4 3 2 1

F

E

D

C

B

A

F

E

D

C

B

A

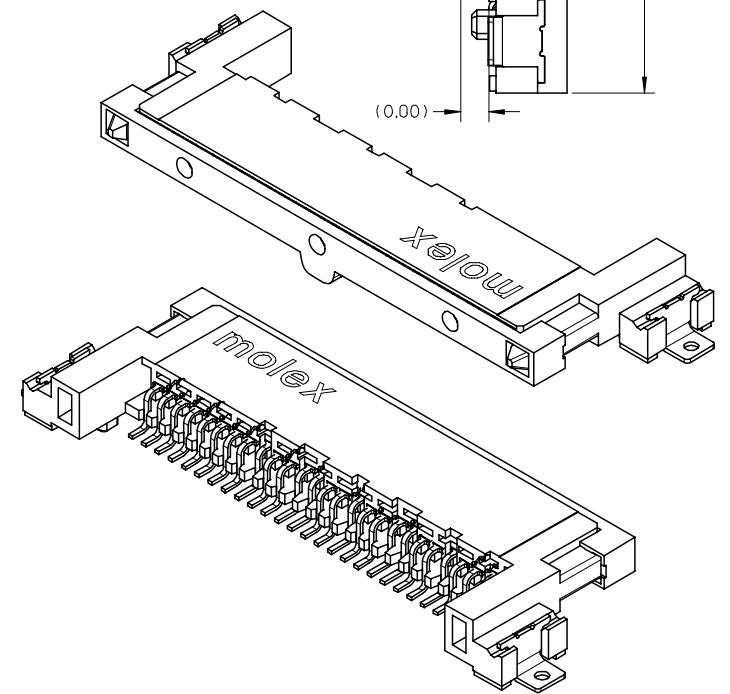
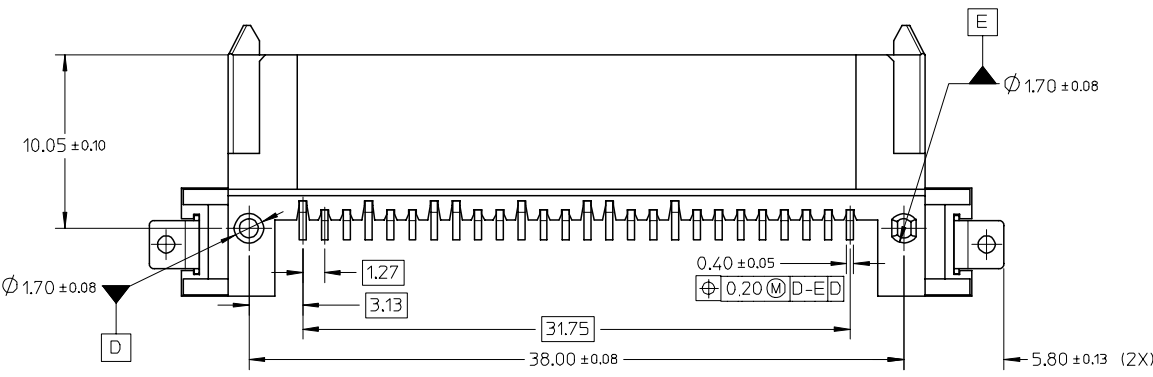
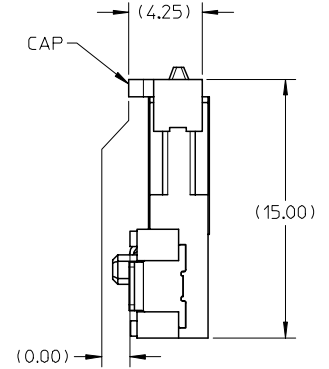
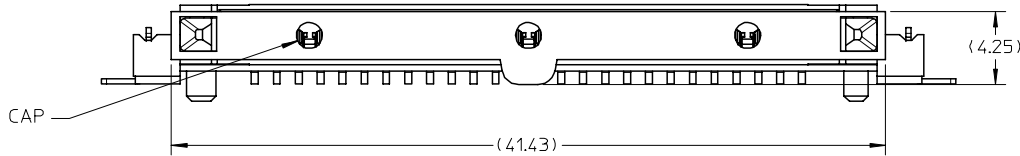

RELEASE EC NO: S2008-0173 DRWNS: SCHEONG CHKD: CGOH APPR: KCLING	2007/09/21 2007/09/25 2007/09/25	DESCRIPTION A	QUALITY SYMBOLS	GENERAL TOLERANCES (UNLESS SPECIFIED)	DIMENSION STYLE	SCALE	DESIGN UNITS	THIRD ANGLE PROJECTION
			$\nabla = 0$ $\sphericalangle = 0$	mm INCH 4 PLACES ± --- ± --- 3 PLACES ± --- ± --- 2 PLACES ± 0.20 ± --- 1 PLACE ± --- ± --- ANGULAR ± 3 °	MM ONLY	NTS	METRIC	
				DRAFT WHERE APPLICABLE MUST REMAIN WITHIN DIMENSIONS	DRAWN BY: SCHEONG CHECKED BY: CGOH APPROVED BY: KCLING	DATE: 2007/08/31 DATE: 2007/09/17 DATE: 2007/09/18	TITLE: 1.27MM PITCH, 26 CKTS R/A, SMT IVDR RECEPTACLE MOLEX INCORPORATED	
					MATERIAL NO. 78159-0001 SIZE A3	DOCUMENT NO. SD-78159-001 SHEET NO. 2 OF 4		

9 8 7 6 5 4 3 2 1

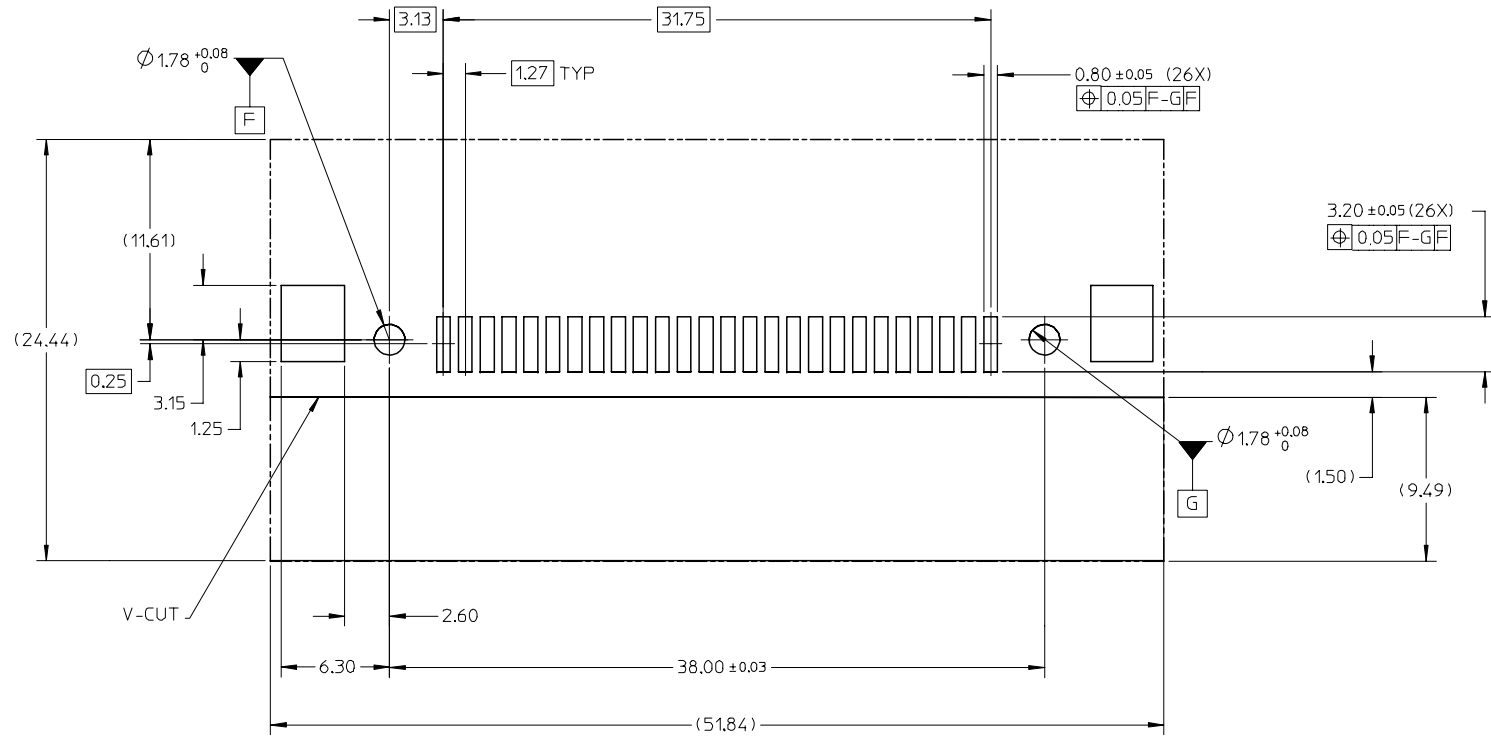

RECOMMENDED PCB THICKNESS: 1.60±0.10

RELEASE EC NO: S2008-0173 DRWNS: SCHEONG CHKD: CGOH APPR: KCLING	2007/09/21 2007/09/25 2007/09/25	QUALITY SYMBOLS ▽=0 ◻=0	GENERAL TOLERANCES (UNLESS SPECIFIED)		DIMENSION STYLE MM ONLY		SCALE NTS	DESIGN UNITS METRIC	THIRD ANGLE PROJECTION			
				mm	INCH	DRAWN BY SCHEONG	DATE 2007/08/31	TITLE 1.27MM PITCH, 26 CKTS R/A, SMT IVDR RECEPTACLE				
			4 PLACES	± ---	± ---	CHECKED BY CGOH	DATE 2007/09/17					
			3 PLACES	± ---	± ---	APPROVED BY KCLING	DATE 2007/09/18	MOLEX INCORPORATED MATERIAL NO. 78159-0001 DOCUMENT NO. SD-78159-001 SHEET NO. 3 OF 4				
2 PLACES	± 0.20	± ---	DRAFT WHERE APPLICABLE MUST REMAIN WITHIN DIMENSIONS									
1 PLACE	± ---	± ---			SIZE A3							

EMBOSSED CARRIER TAPE PACKAGING DETAILS

Ao	16.18±0.10
Bo	51.30±0.10
Ko	6.35±0.10
F	34.20±0.15
P1	20.00±0.10
So	68.40±0.10
W	72.00±0.30

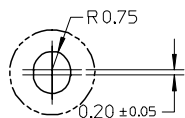

DETAIL 1

∅ 1.50^{+0.10}₀ (PILOT HOLE)

CUSTOMER PULL-OUT DIRECTION

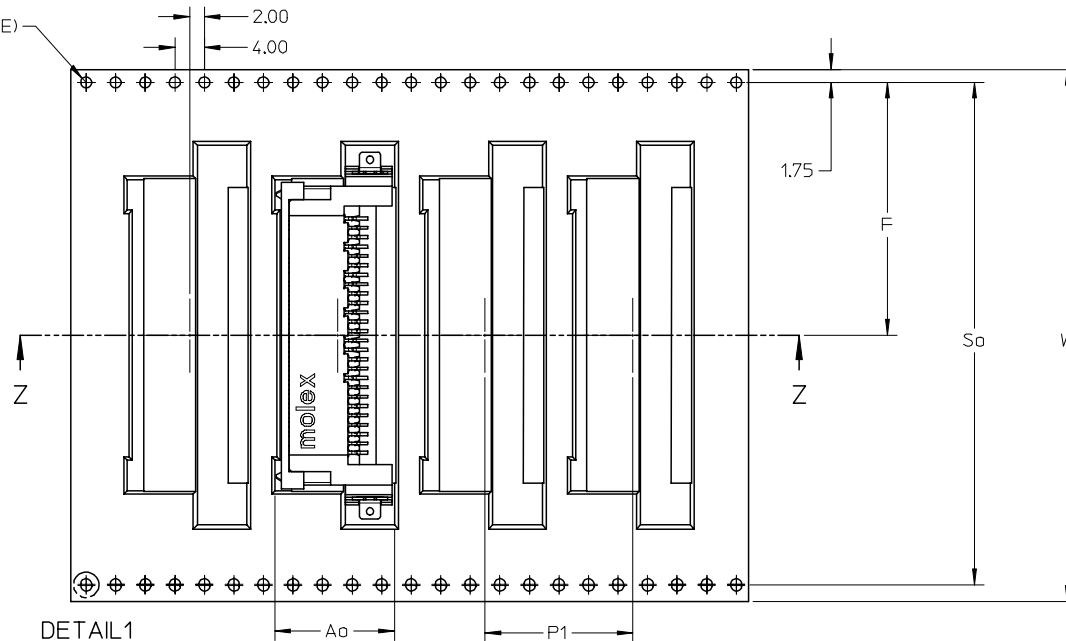

DETAIL 1

NOTES:

1. LEADER AND TRAILER TAPE

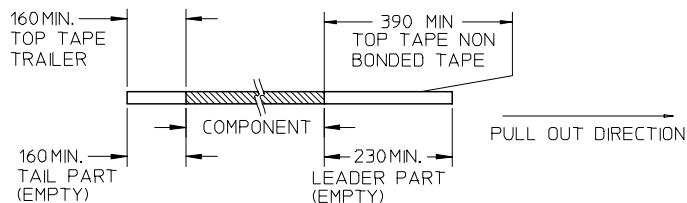

2. PEELING OFF FORCE OF THE TOP TAPE: 20 - 80gf. (PEELING DIRECTION AS SHOWN IN FOLLOWING FIGURE)



- 3. TAPE AND REEL SPECIFICATION IS AS PER EIA-481.
- 4. TAPE AND REEL QUANTITY : 500 PCS/ REEL.
- 5. THE TAPE IS TREATED FOR ANTI-STATIC.

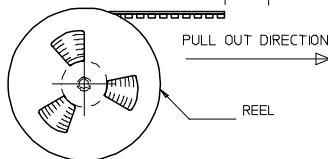

RELEASE EC NO: S2008-0173 DRWNS: SCHEONG CHKD: CGOH APPR: KCLING	DESCRIPTION 2007/09/21 2007/09/25 2007/09/25	QUALITY SYMBOLS	GENERAL TOLERANCES (UNLESS SPECIFIED)	DIMENSION STYLE	SCALE	DESIGN UNITS	THIRD ANGLE PROJECTION	
		$\nabla=0$ $\triangle=0$	mm INCH 4 PLACES ± --- ± --- 3 PLACES ± --- ± --- 2 PLACES ± 0.20 ± --- 1 PLACE ± --- ± --- ANGULAR ± 3 °	MM ONLY	NTS	METRIC		
				DRAWN BY: SCHEONG CHECKED BY: CGOH APPROVED BY: KCLING DATE: 2007/08/31 DATE: 2007/09/17 DATE: 2007/09/18	TITLE	1.27MM PITCH, 26 CKTS R/A, SMT IVDR RECEPTACLE		
				MATERIAL NO. 78159-0001	MOLEX INCORPORATED DOCUMENT NO. SD-78159-001	SHEET NO.		4 OF 4
A	REV		DRAFT WHERE APPLICABLE MUST REMAIN WITHIN DIMENSIONS	SIZE	THIS DRAWING CONTAINS INFORMATION THAT IS PROPRIETARY TO MOLEX INCORPORATED AND SHOULD NOT BE USED WITHOUT WRITTEN PERMISSION			