

Charging

■ Charging circuits

Charging/discharging cycle	Approx. 1,000 times at 10% discharge depth to nominal capacity
Charging system*	Constant-voltage charging (Please strictly adhere to the specified charge voltage)
Operating temperature	-20°C to +60°C

* Consult with Panasonic concerning constant-current charging systems.

The charging circuit is crucial in terms of ensuring that full justice will be done to the battery characteristics. Consider it carefully as the wrong charging circuit can cause trouble.

■ Precautions regarding the charge voltage setting

Under no circumstances should trickle charging, which is used for nickel-cadmium batteries, be used. Ignoring this precaution will cause the battery voltage to rise to about 5V, resulting in a deterioration of performance.

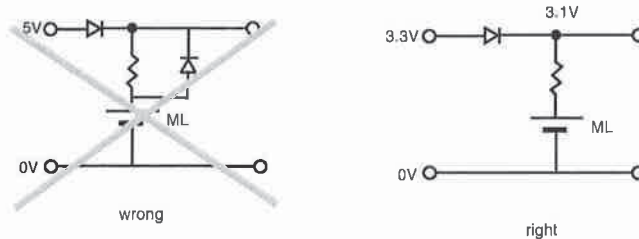

■ Charge voltage range

If a fixed-charging method is applied, please adhere to the specified charging voltage.

Guaranteed voltage is 2.8V to 3.2V at the temperature of -20°C to 60°C.

* If the charging voltage exceeds the specifications, the internal resistance of the battery will rise and may cause battery deterioration. Also, with a charge voltage around 4V, corrosion of the ⊕ terminal (case) may occur, causing leakage. ("Influence of the charge voltage on ML batteries" in chapter 3-61.)

* It is not possible for the battery capacity to recover completely when the charging voltage is below the specification.

■ Recommended charging circuits

● Basic conditions

Fixed-voltage charge

Charge voltage: 2.8 to 3.2V (Standard voltage: 3.1V)

Charge current: For a battery voltage of 2.5V

ML421	Approx. 0.15 mA or below
ML614	Approx. 0.3 mA or below
ML621	Approx. 0.6 mA or below
ML920, ML1220	Approx. 1.2 mA or below
ML2020	Approx. 3.0 mA or below

■ Mixed usage of batteries

Do not use these batteries and lithium primary batteries or other rechargeable batteries together, and do not use new batteries and old batteries together even if they are of the same type.

Reference : ML - Example of Charging Circuits

①

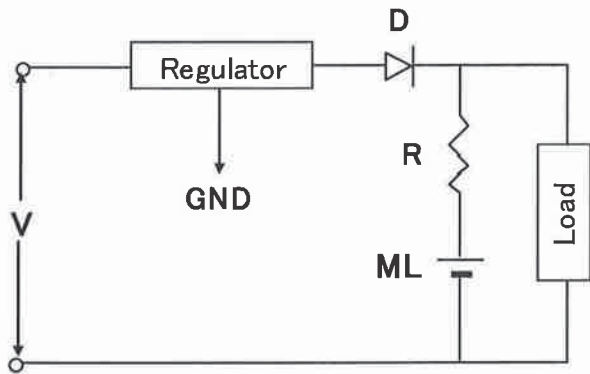

Standard Circuit

Diode D : DB2J314

Model	Reg.	R
ML421	3.2V	6.2kΩ
	3.1V	5.1kΩ
ML614	3.2V	1.8kΩ
	3.1V	1.5kΩ
ML621	3.2V	910Ω
	3.1V	750Ω
ML920	3.2V	470Ω
	3.1V	390Ω
ML1220	3.2V	470Ω
	3.1V	390Ω
ML2020	3.2V	180Ω
	3.1V	150Ω

②

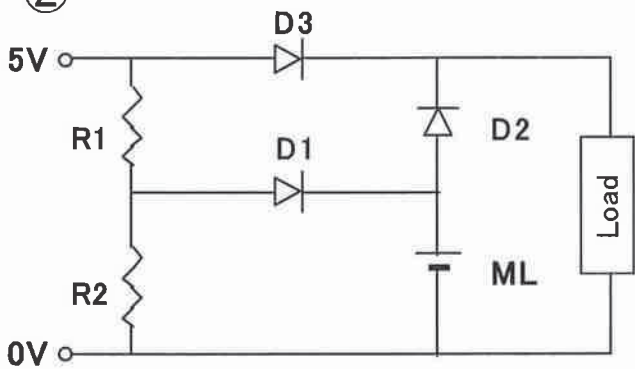

Standard Circuit (Charging from 5V line)

Diode D : DB2J314

Model	R1	R2
ML421	5.6kΩ	10kΩ
ML614	2.7kΩ	5.1kΩ
ML621	1.3kΩ	2.4kΩ
ML920	680Ω	1.2kΩ
ML1220	680Ω	1.2kΩ
ML2020	180Ω	330Ω

For diode D2, select a diode of small inverse current ($I_R = 1\mu A$ below / 5V)

③

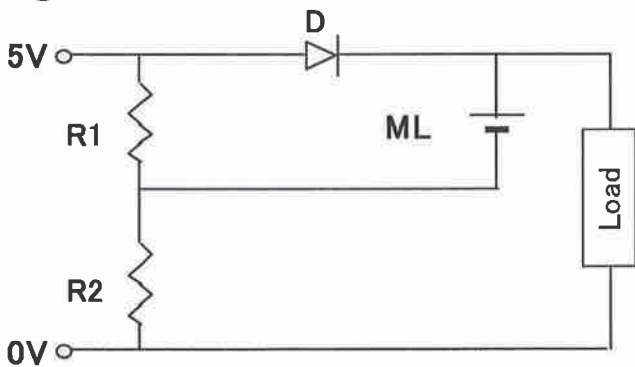

Cost performance type

During charging, there is voltage drop V_f at D.

Diode D : DB2J314

In case the current flows through D is less than 1mA, when the battery is full charged.

Model	R1	R2
ML421	10kΩ	5.6kΩ
ML614	5.1kΩ	2.7kΩ
ML621	2.4kΩ	1.3kΩ
ML920	1.2kΩ	680Ω
ML1220	1.2kΩ	680Ω
ML2020	330Ω	180Ω

※If the current exceeds 1mA, these value of resistances is different.